



USER MANUAL CURTAINSIDER SERIES



Index

1. GENERAL INFORMATION AND SAFETY INSTRUCTIONS	
1.1. About the User Manual	8
1.2. Meanings of Symbols Used in User Manual.....	8
1.3. Terms of Use and Safety Information	9
2. MAIN INFORMATIONS	
2.1. Vehicle Identification Plate	10
2.2. Brake Data Plate.....	10
2.3. VIN (Chassis) Numbers	10
2.4. Warranty and Responsibility	10
3. TRAILER RUNNING GEAR AND USAGE INSTRUCTIONS	
3.1. Brake System	12
3.1.1. Air Couplings.....	12
3.1.2. Compressed Air Tanks	14
3.1.3. EBS Socket.....	15
3.1.4. Roll Stability Support (RSS).....	16
3.1.5. PREV (Park Release Emergency Valve)	16
3.1.6. Brake Chambers	17
3.2. Suspension System.....	19
3.2.1. Manuel Control Lever	19
3.2.2. Auto Reset.....	19
3.2.3. Electronic Controlled Air Suspension (ECAS).....	20
3.2.4. Second Driving Height.....	20
3.2.5. Manometer (Axle Load Indicator)	21
3.2.6. Smartboard (Info Center)	21
3.2.7. TailGUARD	21
3.2.8. Electrical System.....	21
3.3. Light System	24
3.4. King Pin	25
3.5. Landing Gear.....	25
3.5.1. Front Landing Gear's Working Principle.....	25
3.5.2. Rear Landing Gear Working Principle.....	27
3.6. Side Protection Equipment (Side Underrun Protection)	28
3.7. Semi-Trailer Axle System.....	29
3.7.1. Self-Steering Axles	29
3.7.2. Axle Lifting.....	30
3.7.3. Hubodometer.....	31

- 3.8. Tires.....31
- 3.9. Spare Wheel Holder32
- 3.10. Swedish Type Spare Wheel Holder33
- 3.11. Basket Type Spare Wheel Holder34
- 3.12. Crane Type Spare Wheel Holder34
- 3.13. Mudguards.....34
- 3.14. Wheel Chock.....35
 - 3.14.1. Pin Type Wheel Chock Holder35
 - 3.14.2. Pocket Type Wheel Chock Holder35
- 3.15. Boxes and Storage Units36
 - 3.15.1. Steel Toolbox36
 - 3.15.2. Steel Food Box.....37
 - 3.15.3. Plastic Toolbox.....38
 - 3.15.4. Fire Extinguisher Cabinet38
 - 3.15.5. Water Tank39
 - 3.15.6. Document Box39
 - 3.15.7. Pallet Box.....40
 - 3.15.8. Double Deck Bar Storage Box.....40
 - 3.15.9. Stainless Toolbox41
 - 3.15.10. Storage For Side Rows.....41
 - 3.15.11. Pillars Storage42
 - 3.15.12. Front Panel Storage Box42
- 3.16. Rear Bumper (Rear Protection Equipment)43
 - 3.16.1. Fixed Rear Bumper43
 - 3.16.2. Foldable Bumper.....43
 - 3.16.3. Ferry Skid.....44
- 3.17. Floor.....44
 - 3.17.1. Phenol Resin Coated Plywood.....44
 - 3.17.2. Hardwood Floor45
- 3.18. Ladders.....45
 - 3.18.1. Foldable Sliding Ladder.....45
 - 3.18.2. Ladder in Rear Panel.....46
 - 3.18.3. Folding Step.....47
 - 3.18.4. Rear Board Ladder.....47
- 3.19. Tail Lift.....47

4. UPPERSTRUCTURE COMPONENTS AND USE

- 4.1. Overview of Trailer Superstructure Components48
 - 4.1.1. Curtain Tensioner48
 - 4.1.2. Curtain Tension49

4.2.	Curtainsider Superstructure.....	52
4.2.1.	Curtain Structure with Customs Legislation with Board.....	52
4.2.2.	Curtain Structure without Board without Customs Legislation.....	53
4.2.3.	Curtain Structure without Board with Customs Legislation.....	54
4.3.	Tarpaulin Superstructure	55
4.4.	Front Panel	56
4.4.1.	Steel Front Panel	56
4.4.2.	Aluminum Front Panel.....	57
4.5.	Rear Panel	57
4.5.1.	Opening the door.....	57
4.5.2.	Container door.....	59
4.5.3.	Rear door handle	60
4.5.4.	Foldable Rear Board	61
4.5.5.	Side Boards	62
4.5.6.	Ramp buffers.....	63
4.5.7.	Forklift Barrier	63
4.6.	Pillars.....	63
4.6.1.	Rear Pillars	63
4.6.2.	Front Pillars	65
4.6.3.	Middle Pillars.....	65
4.7.	Side Rows.....	67
4.7.1.	Aluminum Side Rows	67
4.7.2.	Wooden Side Rows	68
4.7.3.	Steel Side Rows.....	68
4.8.	Roofs	68
4.8.1.	Lifting Roof.....	68
4.8.2.	Sliding Roof	71
4.8.3.	RSAB	74

5. TRANSPORTATION PROCESS

5.1.	Sürüş Öncesi Kontroller.....	76
5.2.	Semi-Trailer and Tractor Coupling	76
5.3.	Cautions During the Parking and Stopping.....	77
5.4.	Important Technical Considerations	77
5.4.1.	Fire Extinguisher.....	77
5.4.2.	Wheel Chocks	78
5.4.3.	Treylerde Yapılacak Değişiklikler.....	78

5.4.4.	Air Leakage.....	78
5.4.5.	Considerations For the Environment	78
5.4.6.	Cleaning the Vehicle	79
6.	TRANSPORTATION SOLUTION	
6.1.	Coil Material Transport.....	80
6.1.1.	Coil Transport Well.....	80
6.2.	Air Cargo Transport	81
6.2.1.	Roller Control Panel.....	82
6.2.2.	Pallet Stoppers.....	83
6.3.	Load Transportation with Double Deck.....	83
6.3.1.	Using the Double Deck System	84
6.3.2.	Safety Instructions.....	84
6.3.3.	Proper Terms of Use.....	85
6.3.4.	Dangerous Situations	85
6.3.5.	Loading the Vehicle.....	85
6.4.	Paper Transport	86
6.5.	Intermodal Transport.....	86
6.6.	Tyre Transportation.....	87
6.7.	Customs Legislation.....	87
6.7.1.	Semi-Trailer Structure in Accordance with Customs Legislation.....	88
6.7.2.	Dangerous Goods Transportation (ADR)	88
7.	LOADING AND LOAD SECURITY	
7.1.	Loading – Unloading Operations	90
7.2.	Loading	90
7.3.	Safety Instructions.....	90
7.3.1.	Load Security	91
7.4.	Load Distribution and Load Limits of Tractor Semi-trailer Combination	92
7.5.	K-Fix Side Rave.....	92
7.6.	Lashing Rings.....	92
7.6.1.	U Type Lashing Rings.....	92
7.6.2.	Load Lashing Rings Placed on the Floor	93
7.7.	Lashing Rails.....	93
7.8.	Lashing Profiles	93
7.9.	Ferry Rings.....	93
7.10.	Pallet Stopper	94
7.11.	Telematic	95

7.12. Load Security Certification.....95

8. INSPECTION AND MAINTENANCE

8.1. Safety Instructions.....96
8.2. Main Principles96
8.3. Checks to Be Performed Of The Time of the Delivery96
8.4. Cathaphoresis Coating96
8.5. Galvanized Coating.....96
8.6. Periodic Maintenance and Controls97
8.7. Trouble Shooting.....97
 8.7.1. Safety Regulations97
 8.7.2. Spare Tire Replacement97

FOREWORD

First of all, thank you for choosing us for your new vehicle investment.

Your vehicle is manufactured with the latest production technologies to the highest quality standards and equipped with the best safety and efficiency features.

You can find detailed information about the accessories, equipment and hardware that might be in your vehicle in this manual. The defined options in this manual can vary according to the vehicle specs.

Important information on how you can use your vehicle is explained in this user manual, please be sure that you review and understand the content. We suggest keeping this user manual available in your vehicle at all times. This information is specified in the product's user manual. We recommend you read this operating manual thoroughly to get the most out of your vehicle.

** Owing to the developments in product research, the manufacturer reserves the right to make any changes in the product, without any prior notice. The publication rights of this documentation belong to the manufacturer.*

1. GENERAL INFORMATION AND SAFETY INSTRUCTIONS

1.1. About the User Manual

The usage and operation information given in this manual is prepared to make sure the vehicle is used in compliance with its purpose and as desired.

The instructions here contain important recommendations to perform your operations safely, completely, and in the most efficient manner. Complying with these instructions, warnings and recommendations will prevent accidents, decrease down-time & repair costs, and make sure you use your vehicle safely, reliably and problem-free.

Please read the operating instructions in this manual carefully and completely. The manufacturer is not liable for the damages and deficiencies caused by the failure to comply with these instructions. The instructions herein must be supported by local laws, rules and regulations. Please comply with these instructions to prevent accidents and protect your surroundings and the environment.

Any usage of transportation that goes beyond the use in accordance with the rules will be considered improper use.

Transportation of the following is not allowed:

- Carrying people and live animals
- Transportations that need to be carried according to special instructions, e.g., dangerous good transportations
- Transportation of unsecured goods
- Transportation of materials that are dangerous due to their properties or that need to be carried with special equipment
- Exceeding technically and legally permissible weights of the axles or king pin load

- Exceeding of the maximum vehicle speed
- Exceeding the permissible length, width and height
- Unapproved parts like tires, accessories, spare parts and etc. by the manufacturer
- The manufacturer shall not accept any responsibility for the problems and faults that occurs that are not in compliance with the purpose of the vehicle's usage. All the risks of this issue belong to the customer.

 **It is necessary to keep the user manual available on the vehicle at all times.**

 **The vehicle can be equipped with a lot of different options. The standard or optional features will be explained in the manual. Some options may not be available for your vehicle**

 **Adhere strictly to the operating instructions when using your vehicle. When problems occur which can lead to dangerous consequences, contact the service centre immediately.**

1.2. Meanings of Symbols Used in User Manual

Several warnings are available in this manual to ensure maximum safety when using your vehicle. Each warning is indicated by a special symbol. These symbols and their meanings are as follows.



The information specified by this warning symbol is very important for health and human safety. When the given information is ignored, serious damage, injuries and even death may occur.



This symbol specified in this manual indicates that critical accidents may occur when the instructions do not comply.



This symbol is used when additional information is required.



This symbol is used when chemicals and other substances can be disposed of with precautions that will not harm the environment.

1.3. Terms of Use and Safety Information

It is necessary to keep the warranty, operating and maintenance manual and other documentation about the vehicle available on the vehicle at all times.

To prevent possible accidents and environmental pollution, follow the operating instructions and binding regulations.

- Pay attention to the safety and warning signs placed on your vehicle.
- Always keep these safety and warning signs completely visible.
- Make sure that the load carrier is secured properly.
- In case of any dangerous condition in the operation of safety, stop your vehicle immediately and inform the authorized people or institutions.
- Do not modify anything on the vehicle without a written manufacturer's approval. Your vehicles guarantee terms do not cover unapproved modifications.
- The spare parts must meet the technical requirements set forth by the manufacturer company. Only the original spare part/parts meet their requirements.

2. MAIN INFORMATIONS

There are vehicle identification stickers on the vehicle.

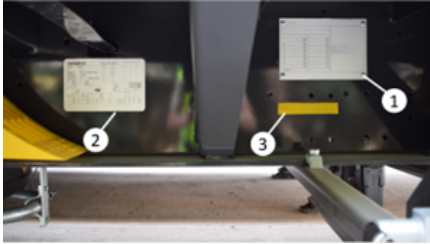

2.1. Vehicle Identification Plate

Vehicle identification plate (1) is located on the right side of the vehicle.

You may find the following information's on this plate;

1 xxx"xxxx/xx"xxxx			
2 xxxxxxxxxxxxxxxxxxxx			
7 xxx.xxx kg	7 xxx.xxx kg		
0 xxx.xxx kg	0 xxx.xxx kg		
1 xxx.xxx kg	1 xxx.xxx kg		
2 xxx.xxx kg	2 xxx.xxx kg		
3 xxx.xxx kg	3 xxx.xxx kg		
4 - kg	4 - kg		
5 - kg	5 - kg		
T - xxx.xxx kg	T - xxx.xxx kg		
Type: xx	11		

Vehicle Identification Plate

- 1- Type approval number
- 2- VIN number
- 3- Technical total capacity
- 4- Technical king pin capacity
- 5- Technical an axle capacity
- 6- Technical total axle capacity
- 7- Nationally approved total capacity
- 8- Nationally approved king pin capacity
- 9- Nationally approved an axle capacity
- 10- Nationally approved total axle capacity
- 11- Vehicle Type

2.2. Brake Data Plate

There is a brake data plate (2) on the vehicle which is equipped with an EBS system.

You may see this information on this plate;

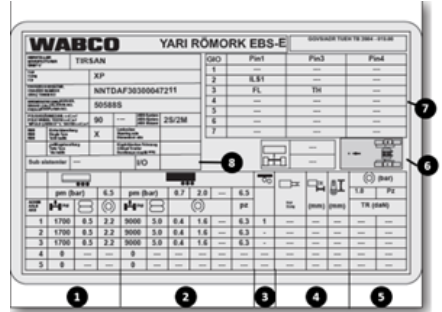

EBS plate

1	Empty vehicle (without load)
2	Loaded vehicle
3	Axle lifting
4	Brake chamber data's
5	References
6	Driving height
7	Pin positions
8	IN/OUT-Connections

2.3. VIN (Chassis) Numbers

The VIN (chassis) number (3) is located on the right side of the vehicle and marked with a different color than the chassis color.

2.4. Warranty and Responsibility

Our trailers, semi-trailers and truck on-board applications are manufactured in compliance with regulations and our

quality standards. It is necessary to perform the maintenance to ensure our products always operate in the most efficient manner in compliance with our latest directives and maintenance programs. The warranty starting date is the date that the vehicle is delivered to the customer.

The performance of maintenance and repair/servicing of the vehicle with the use of original spare parts by authorized service shall assure the client's warranty rights. This warranty is based upon the usage and maintenance conditions described herein and in the warranty book. Thus, it is important to read and understand this operation manual and warranty book.

It is necessary to keep the warranty, always operating and maintenance manual available on the vehicle to allow authorized service performing the servicing to see the warranty conditions and maintenance records. In the repairs made during the warranty period, the authorized service performing the repair will demand this. Purchasing one trailer or semi-trailer is an important investment. For the highest return on your investment, it is necessary to comply with the manufacturer's procedures and recommendations during the operation period of the vehicle. The information provided by the client/driver related to the warranty written in this manual shall be kept within our database.

3. TRAILER RUNNING GEAR AND USAGE INSTRUCTIONS

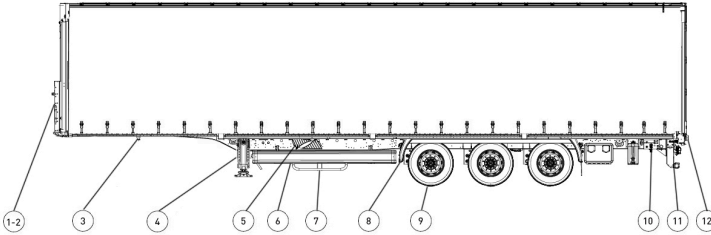

1- 2 Brake/Electric Connections

3 King Pin

4 Extinguisher box

5 Wheel Chocks

6 Underun Protection

7 Spare Tire Carrier

8 Fender

9 Tire

10 Suspension Control Panel

11 Bumper

12 Dock Bumper

3.1. Brake System

3.1.1. Air Couplings

The main connection between the truck and trailers is air couplings.

Generally, 3 different types of air couplings are used in the trailers. These 3 types of air couplings have the same function but with different shapes and connections. There are 2 different air supply lines in the system.

Brake Line (Yellow)

Supply Line (Red)

Service Line: Pneumatically air hose which will feeds the brake line.

Supply Line: Pneumatically air hose which will feeds the air tanks and trailer

According to the type of vehicle, your vehicle can be equipped with one or two different types of air couplings.

- Standard Couplings (Palm)
- Duomatic Coupling
- C (UK) Couplings



If your vehicle is equipped with 2 different types of couplings, you must use only one type at the same time.



When the couplings are mounting/demounting, the parking brake of the truck and trailer must be engaged.



If the brake parameters are modified, your vehicle's brake calculation might be non-suitable for regulations. Only authorized services must service to the EBS modulator.



Only authorized services and personnel should make service operations for the brake system.

There might be test points on the chassis or above the air couplings. When you remove the test points rubber protection parts and push the points you can check the air pressure on the brake lines.



Test point



Palm coupling with a test point

3.1.1.1. Mounting of Standard (Palm) Couplings

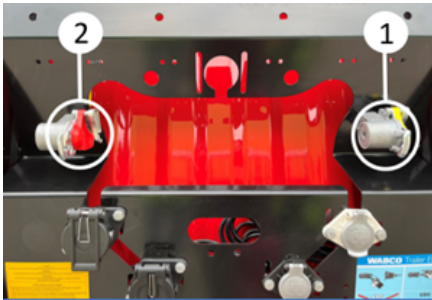

Couplings

- Slightly slide plastic covers to the upper side. Slide plastic covers to upper side
- Be sure that sealing surfaces are clean and durable. If necessary, clean/change the air coupling.
- The coupling which comes from the truck should be pushed slightly from the upper side to the lower side and

connect the coupling. Be sure that couplings are matched correctly.

- First mount service line yellow (1).
- Mount supply line red (2).

3.1.1.2. Demounting of Standard (Palm) Couplings

- The coupling which comes from the truck should be pushed slightly from the lower side to the upper side and demount the coupling.
- First demount the supply line red (2).
- Demount the service line yellow (1).
- Slightly slide plastic covers to the lower side and close the plastic covers.

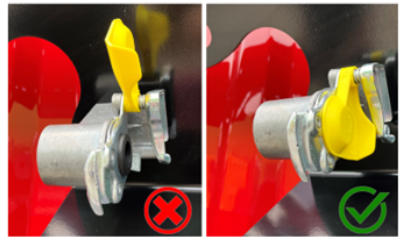

Closing the coupling



Driving with a non-suitable air connection is dangerous and forbidden



Using damaged air supply parts can cause serious hazards. Torn or damaged compressed air connectors reduce the vehicle's braking performance.

3.1.1.3. Mounting of C (UK) Couplings

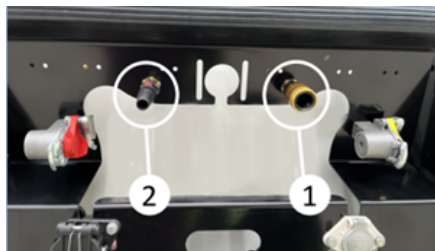

Mounting the C (UK) Couplings

- Be sure that sealing surfaces are clean and durable. If necessary, clean/change the air coupling.
- First mount service line yellow (1).
- Mount supply line red (2).
- Be sure that couplings are matched correctly.

3.1.1.4. Demounting of C (UK) Couplings

- Push the latch from front to back side on the C couplings and remove.
- First demount the supply line red (2).
- Demount the service line yellow (1).



The coupling filters have to be clean regularly.

3.1.1.5. Mounting of Duomatic Coupling



Duomatic Coupling Connection

- Be sure that sealing surfaces are clean and durable. If necessary, clean/change the air coupling.
- Push the arm and mount the coupling (1).



The coupling filters must be clean regularly.

3.1.1.6. Demounting of Duomatic Coupling

- Push the arm and mount the coupling (1).
- Pull back the arm slightly and close the coupling cover.

3.1.2. Compressed Air Tanks

Pressured air can be stored in the air tanks.

The quantities and capacities of the air tanks can be changed according to your vehicle specifications.

In cold periods of the year or when the air humidity is high, the moisture in the air can be condensed and collected in the compressed air tank.

The tractors are generally fitted with air driers to prevent condensation in compressed air. The tractors are generally

fitted with air driers to prevent condensation in compressed air. Even if the air driers system, the humidity in the air can be condensed. The condensed water must be drained out via the drain valve.

The water in the air tanks should be completely drained out. That's why please push the valve on the air tanks.





1. Compressed Air Tanks

2. Drain valve

 The water in the compressed air tank can cause corrosion problems and affect the functionality of the brake system. The frozen water in the pneumatic lines can cause the failure of the brake system.

 The water in the pneumatic system should be checked more frequently in cold weather or extremely variable outside temperatures.

 When the air tank pressure is lower than 4,5 bars, the EBS warning lamp on the tractor turns on and the driver can see this situation.

 When the pressure in the service line (in the red coupling) is lower than 2,5 bars, the brakes automatically lock.

3.1.3. EBS Socket

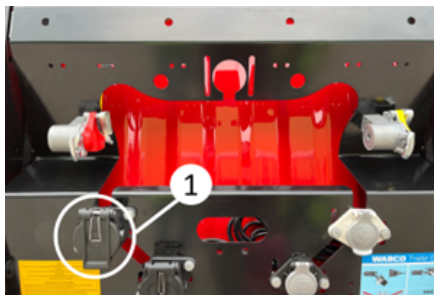

EBS Socket

Our trailers and semi-trailers are equipped with an EBS system.

EBS is an electronically controlled brake system, that is fitted with automatic load sensing braking pressure regulation (ALB) and automatic anti-skid systems (ABS/ABV).

To activate the EBS system, your truck and trailer must be equipped with an EBS system. Please mount the EBS cable that will come from the truck to the EBS socket on the trailer.

- Driving with a non-connected EBS connection is illegal.
- Drive only with an approved and well operating EBS plug connection in accordance with regulations.
- EBS connection must be made between the truck and trailer.
- When the EBS socket mounted and truck engine is activated, you will hear the noise. Please listen and check carefully.
- A system control is performed two seconds after the trailer EBS is switched on; in the meantime, the magnets may be opened and closed audibly for a short time. When plugging the EBS connector, if you cannot hear the system control, a power supply problem exists between the tractor and EBS.

When the truck engine is activated and during the travel, the EBS system will be checked automatically. If the truck screen is suitable/adjusted, the EBS failures will be shown with the EBS mistake lamp.

The EBS mistake lamp on the truck screen will be turned on when the ignition key is activated. If there is no failure on the EBS system, the lamp will be turned off in appr. 2 seconds.

After 7 km/hours speed, If there is a failure on the EBS system (Sensor mistake and etc.) EBS lamps will be flashed.

If the EBS lamp is activated, please contact with authorized services immediately.

 **The trailers equipped with a Trailer EBS E braking system may only be used with tractors with**

- ISO 7638-1996 connectors (ABS + CAN) or ISO 7638, 7 pin with CAN data line (EBS Truck)

 **If you drive without EBS connectors or if there is a problem on the EBS system, the brake system will not be worked properly. This situation may cause an accident.**

 **Trailers are equipped with an additional power supply for the EBS system. Thanks to the extra power supply from brake lamps, when the EBS connector is damaged, an extra safety function will be activated. The EBS system will be fed from brake lamps and ALB (automatic load sensing braking pressure) and ABV (anti-skid system) functions will be activated.**

3.1.4. Roll Stability Support (RSS)

Rollover stability support (RSS) is integrated into the trailer modulator. But don't forget that this system cannot cancel the laws of physics. The vehicle's electronic control unit analyzes wheel speed, load information and transverse acceleration data to detect the likelihood of vehicle roll-over before the driver realizes there is a risk and automatically applies the brakes. But don't forget that this system cannot cancel the laws of physics.

When the roll-over risk is detected, the EBS system makes automatically brakes and tries to reduce the roll-over risk. After risk, the RSS function will be shut down automatically.

 **The RSS optimizes driving characteristics and in emergencies may help to prevent accidents. But cannot completely guarantee.**

3.1.5. PREV (Park Release Emergency Valve)

Generally, brake control systems will be located on the driver's side. It may be different on your vehicle according to the vehicle's construction.

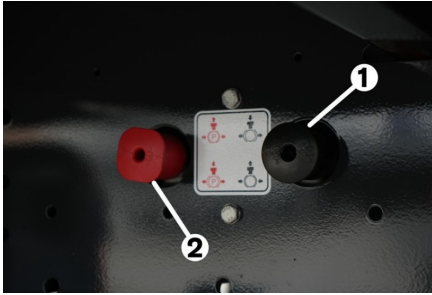

PREV Buttons

Black button (1):Service brake button.

Red button (2):Park brake button

 **When you are driving the trailers, the red button must be pushed position and the black button has to be pulled position.**

3.1.5.1. Service Brake

Thanks to the service brake, the trailer can be made maneuvers without air connections. The black button can be used only without air connections on the trailer.

When you push the black button, the service brake will be disabled. When you pull the black button, the service brake will be activated.

 **If the service brake is used a lot of times, without an air connection, air pressure in the system and braking power may reduce.**

When the air connections are de-mounted, the service brake will be automatically activated. When the air connections are mounted, the service brake will be automatically disabled.

 **The service brake is not suitable for braking of the semi-trailer permanently. During longer waiting periods, the semi-trailer must be secured with a spring - loaded park brake and with wheel chocks.**

3.1.5.2. Spring Loaded Park Brake

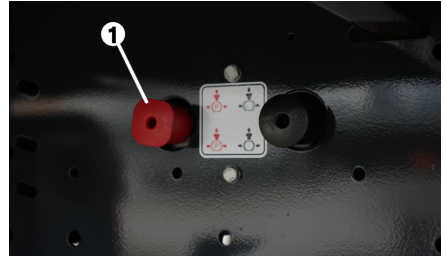

Spring loaded park brake

Spring loaded park brake control button is used for longer parks of semi-trailers with or without tractor on plain or inclined lands.

When the red button is pulled, spring loaded park brake will be activated. When the operator pushes the red button, spring loaded park brake is deactivated.

 **This brake will not be deactivated automatically. Before driving, the operator must deactivate the brake.**

3.1.6. Brake Chambers

Your vehicle may be equipped with disc or drum brake axles according to your choice. For both brake types, the brake chambers are going to use for braking. The brake chambers will be chosen according to axles type and loading capacity. The maintenance, modification or repair operations must be performed by authorized services.

3.1.6.1. Manually Deactivation of Parking Brake Spring

The Parking brake spring may be deactivated manually in emergency situations.

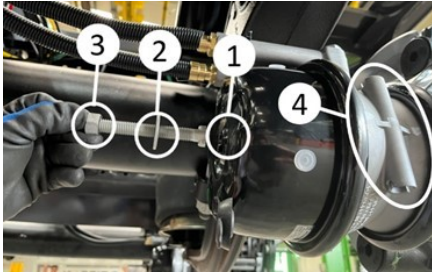

Deactivation of brake chambers

1. Boreholes
2. Release rod
3. Nut
4. Slot of the release rod

- Remove the release rod (2) from the slot (4).
- Insert the release rod (2) to boreholes (1) and screw till the rod (2) will be fitted completely.
- Completely screw in the nut (3) to the release rod (2).

The brake chambers will be deactivated after this operation. In this case, the brake chamber only works on the service brakes. Even if the trailer air tube pressure drops below 2.5 Bar, the spring brake will not be activated due to this operation.



On some brake chambers used in vehicles, the emergency release screw is located in its socket (1) behind the brake chamber, not in its socket (4) next to it. In order to disable the springs, it is allowed to come out by simply turning it with the appropriate key.



This operation should only be used until the trailer is serviced.



Before this operation, the vehicle must fixed securely with wheel chocks. Serious injuries may occur.

3.1.6.2. Activation of Brake Chambers

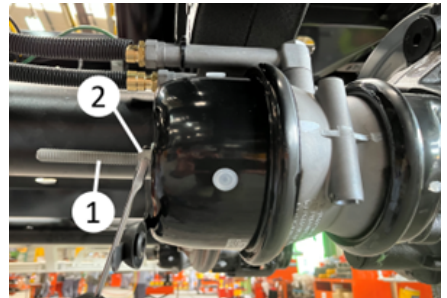

Activation of brake chambers



- Remove the nut (1) from release rod (2) with a spanner.
- Remove the release rod (2).
- Screw the release rod into its place on the brake chambers (3)

- Close the plastic cover on the brake chamber.

Brake chamber will be activated after this operation.

 **Before this operation, the vehicle must be fixed securely with wheel chocks. Serious injuries may occur.**

 **Don't drive without being sure that all the brake system is working properly after this operation**

3.2. Suspension System

Your vehicle is equipped with air suspension system.

3.2.1. Manuel Control Lever

Operation;

In the driving position, the air suspension system keeps the semi-trailer permanently at a certain level independently from the load. The lowering/raising lever (1) at the control panel can lower or raise the semi-trailer. for ramp adjustment on the loaded position.

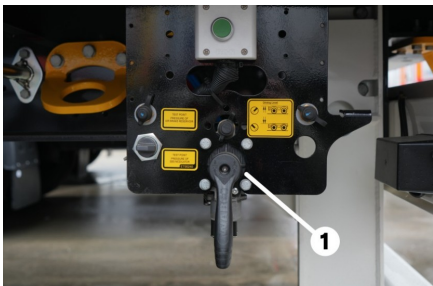

Driving position of lever

You may turn the lever according to anti-clockwise and raise the trailer.

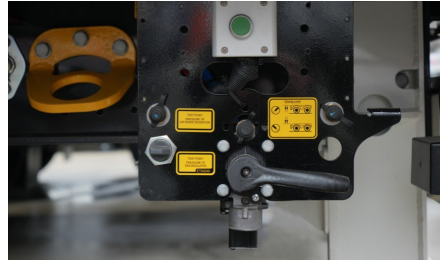

Raising of suspension

You may turn the lever according to clockwise and lower the trailer.

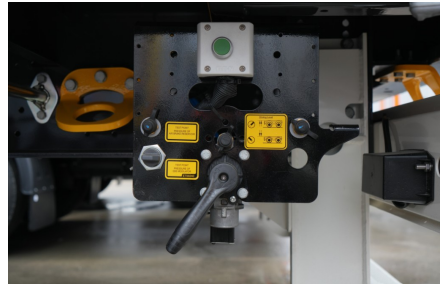

Lowering of suspension

To fix the suspension height, you may turn the lever 45° or 135° according to the photo in below. Before driving, the lever must be switched to driving position.

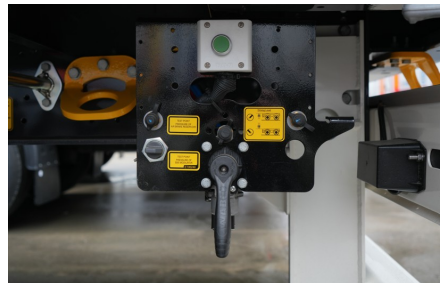

Fixing of suspension height

 **If the trailer will be driven at a non-driving height, the vehicle may be damaged, or a height problem may occur.**

3.2.2. Auto Reset

The auto reset lever can be controlled by the same method as 3.2.1. manual

suspension control lever. When the EBS socket is mounted and driving at a speed defined by the producer, the lever will set the driving height automatically.

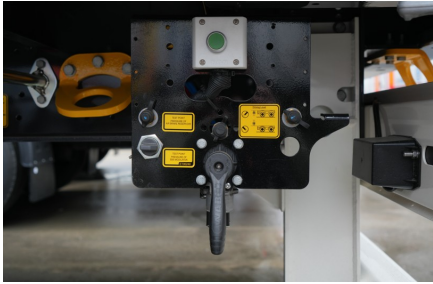

Auto reset

3.2.3. Electronic Controlled Air Suspension (ECAS)

Electronic controller air suspension (ECAS) is an optional solution. This system sets the driving height or defined different heights electronically. When the EBS socket is mounted and driving at a speed defined by the producer, the lever will set the driving height automatically.

You may push the lower or raise button and set the vehicle height.



ECAS control panel

3.2.4. Second Driving Height

If your vehicle is equipped with this system, you may use your semi-trailer with 2 different fifth Wheel height. Please

check your vehicle's technical specs to see the 5th Wheel height.

3.2.4.1. Manuel Control

You may choose the fifth Wheel height with a control button which is located at the driver side.

When you set the button in position 1, you may use your semi-trailer in a lower fifth wheel height and when you set the button in position 2, you may use your semi-trailer in a higher fifth wheel height.

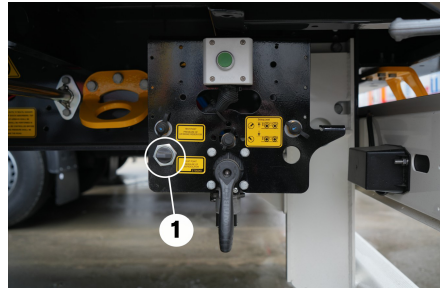

Lower driving height

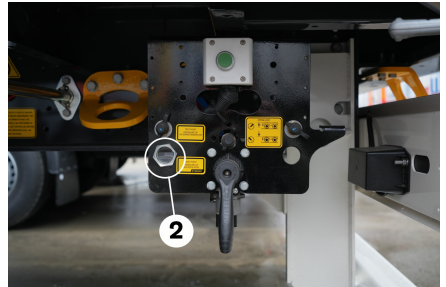

Higher driving height

3.2.4.2. Controlled with Air Couplings

If your vehicle is equipped with 2 different types of air couplings, the fifth wheel height will be chosen automatically.

When you drive with standard palm-type couplings, the vehicle is positioned according to the lower fifth wheel height.

When you drive with C type or duomatic type couplings, the vehicle is positioned according to the higher fifth wheel height.

3.2.5. Manometer (Axle Load Indicator)

The manometer which will show the axle estimated axle load may be positioned at the driver side. The manometer will connect to fixed type axles air bags (non-steering and without axle lifting).

When the air bag pressure is bigger, you will see bigger values on the manometers.



Manometer

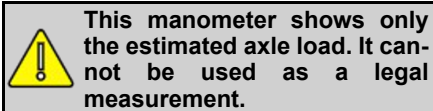

This manometer shows only the estimated axle load. It cannot be used as a legal measurement.

3.2.6. Smartboard (Info Center)

Thanks to Smartboard, the operator may see failure codes, axle load etc. information and control the axle lifting system.



Smartboard

If your Smartboard includes the battery, you may use some control even if the truck is not connected.

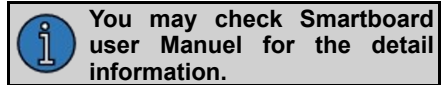

3.2.7. TailGUARD

When the truck is driving back, 2 or 3 sensors Wabco Tail GUARD detects the object behind the vehicle and improve the safety.

After 9 km/h, the system will brake automatically and inform the driver. If the object is too close, the vehicle stops automatically.



TailGUARD

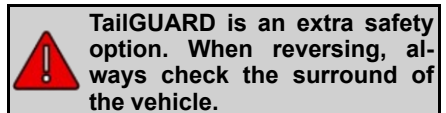

3.2.8. Electrical System

15 pin (1), 2x7 pin (2) or 15 pin+2x7 pin (1+2) electrical sockets are option in our vehicles. Thanks to these sockets,

electrical connections between truck and trailer will be made.

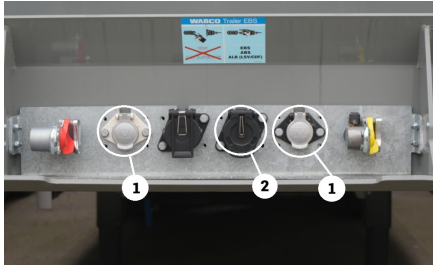

Electrical System

When driving, the electrical sockets between the truck and trailer must be connected.

Please be sure that the truck and trailer are suitable for the norms/standard about electrical systems. Otherwise, electrical problems will occur.

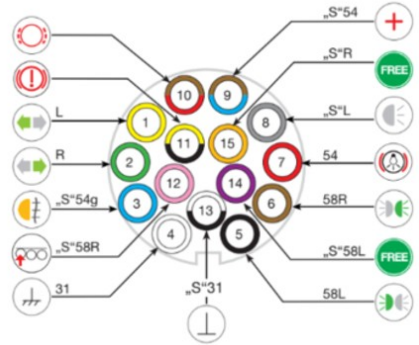

Pin	Meaning
1	Left indicator
2	Right indicator
3	Fog lamp
4	Ground
5	Left taillight
6	Right taillight
7	Brake light
8	Reverse light
9	Supply line
10	Brake Lining Wear
11	Traction help/Force Lowering

12	Axle Lift
13	Chassis Electronics
14	Empty
15	Empty

5	Empty
6	Axle Lift
7	Fog lamps

3.2.8.2. 2x7 Pin Socket

This system provides electricity for the electrical system on the vehicle like stop lamps, signal lamps etc. 2x7 pin socket pin connections are made suitable for 24S ISO 3731 and 24N ISO 1185 norm.

Open the protection cover and mount the sockets regularly.

You may find extra information about the pins function in below.

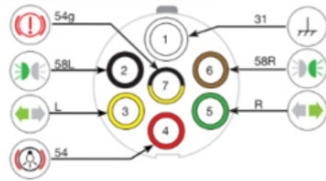

ISO 1185 Socket



ISO3731 Socket

Pin	Meaning
1	Ground
2	Left taillight
3	Left indicator
4	Brake light
5	Right indicator
6	Right taillight
7	EBS

Pin	Meaning
1	Ground
2	Empty
3	Reversing lamp
4	Supply line



Please be careful with the color of the sockets. The black socket is suitable for ISO 1185 and the white socket is suitable for ISO 3731. If the vehicles are suitable for norms, the

black socket on the truck will be connected to the black socket on the trailer and the white socket on the truck will be connected to the white socket on the trailer.

3.3. Light System

The vehicle is equipped with a light system which is suitable for the regulations.

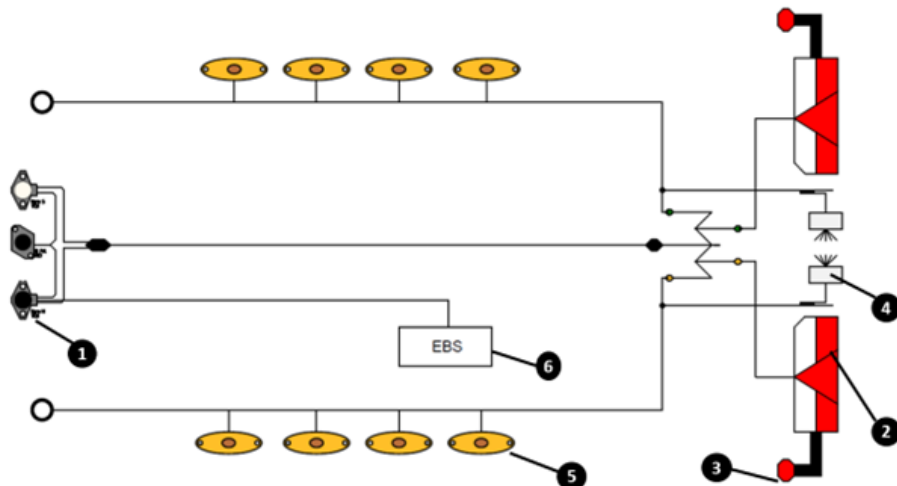

1	Electrical Sockets
2	Stop Lamps
3	End Outline Markers
4	License Plate Lamps
5	Side Position Lamp
6	Modulator

The lamps must be checked regularly. If there is any problem with the electrical system, it must be repaired immediately. In a repair operations, only original and approved sockets or parts must be used.



If you add or remove any lamps on the vehicle, your vehicle may be non-suitable for regulations.



Vehicles with LED electrical systems consume very low energy. For this reason, although there is no problem in the system, it may cause the failure lamp to come on in old tractors.



Repairing operations of the electrical system have to be made by only authorized services. Otherwise, electrical problems may occur or your vehicle may be out of warranty.

3.4. King Pin

King pin is a shaft which connects truck and railer together. Your vehicle may be equipped with 2" or 3.5" diameter pins. Please check the king pin diameter before connecting the truck.

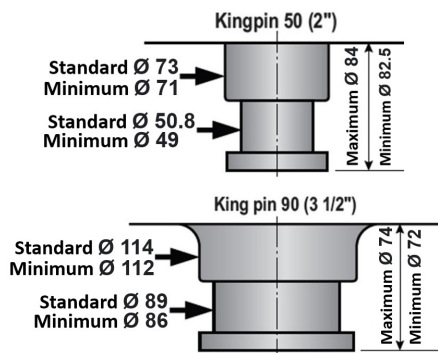

If you match the truck and trailer with a different diameter king pin, injuries may occur.

The flanged king pin is used on the vehicle. That's why king pin can be replaced easily.



Kingpin



If the wearing on the king pin is bigger than 2 mm, the king pin must be replaced.

Your vehicle may be equipped with a double king pin slot. You can remove the bolts around the king pin and mount king pin to the other slot. Please be careful about the total length of the vehicle according to country regulations and be sure that the total length is suitable for regulations.

3.5. Landing Gear

There is a front landing gears behind the vehicle's gooseneck area so that your vehicle can stop in park without truck.

3.5.1. Front Landing Gear's Working Principle

The landing gear crank handle (1) should be removed from its holder (2) and brought to a perpendicular position to the vehicle.

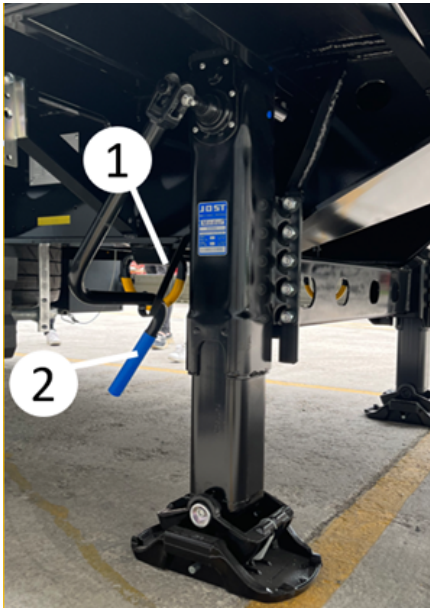

Landing Gear

Low Speed (A): When the crank handle (1) is turned in the fully pressed position, it raises / lowers at low speed.

High Speed (B): It performs high speed lifting / lowering when the lever turned in the fully extended position. The position is used to quickly lower the gear until the foot (plates) touch the ground during the process of separating the semi-trailer from the tractor, or to raise the gear quickly after the semi-trailer is connected to the tractor.



The landing gear crank handle is usually located on the passenger side of the vehicle.

 In all conditions, secure the semi-trailer against tipping with correctly positioned wheel wedges. If the vehicle is not properly secured, the landing gear or the vehicle may be damaged.

 If the loading / unloading operation is performed while semi-trailer is not paired with the tractor, the front or rear of the vehicle may raise. Serious accident and damaged may occur. For this reason, the semi-trailer must be paired with the tractor during the loading and unloading operations.

 If the tractor leaves from the loaded trailer, be sure that the load is distributed homogeneously in the vehicle. Otherwise, the front or rear section of the vehicle may be raised due to centre of gravity, and accident may occur.

In order to protect the landing gear, be sure that there won't be any lateral movements on your vehicle. For this reason give attention to the following criteria:

- Disconnect the semi-trailer from the tractor only when the landing gear are in the middle (neutral) position.
- If you will park for a long time without the coupled tractor, be sure that air suspensions are lowered and after that adjust the landing gears. Thus, the loading area will be parallel to the ground.



Landing gear view

Optionally, an aluminum landing gear can be supplied.

 **Before you start to drive operations, make sure that the landing gear is turned off (highest position).**

3.5.2. Rear Landing Gear Working Principle

Foldable or fixed type mechanical landing gears are optionally offered at the rear of the vehicle. These gears can be opened during the loading/unloading operations to fix the vehicle. Thanks to these legs, movement caused by the air suspension will be minimum.

 When the semi-trailer is loading with heavy cargo from the rear (forklift, pallet trucks, you must support the rear of the semi-trailer with the rear landing gears.

 Vehicle height (ramp height) must not be changed with the help of the rear landing gear. After the vehicle is brought to the desired height with the help of the suspension, the landing gear should be activated.

 Before you start to drive operations, make sure that the landing gear is turned off.

3.5.2.1. Fixed Type Rear Landing Legs



Fixed Type Rear Landing Gear

The usage of the fixed type rear landing gear is the same as the use of the front landing gear described in section 3.5.1.

3.5.2.2. Foldable Type Rear Landing Gear



Foldable Type Rear Landing Gear

Activation of the foldable type of rear landing gear.

- Pull locking pin (1) towards you and open the landing gear carefully.

 **There is a danger of the landing gear falling suddenly towards the ground. For this reason, it should be opened carefully by holding the landing gear with one hand.**

- When the landing gear is vertically positioned, the locking pin(1) should be closed and the landing gear will be fixed.

After this stage, the usage of the landing gear is the same as the usage of landing gear described in section 3.5.1.

Closing of the foldable type landing gear:

- Pull locking pin(1) towards you and lift the landing gear carefully.
- When the landing gear will be parallel to the ground, use the locking pin(1) and fix the landing gear.

3.6. Side Protection Equipment (Side Underrun Protection)

The underrun protection must be in the off position during the travel. Some underrun protection equipment can be opened upwards for easier service operations such as accessing the spare wheel holder.



Side Underrun Protection

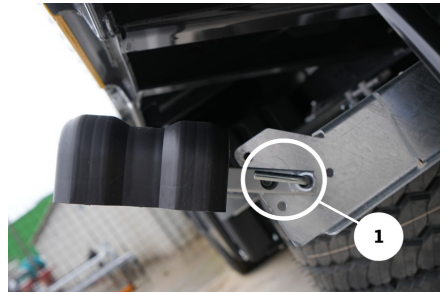

Opened Position



Closed Position

 **Travelling with the lifted side underrun protection is dangerous and illegal. In this case, there may be serious injuries, including death, in road accidents that may occur. Before travel, make sure the side underrun protection is lowered and properly secured.**

Lifting Underrun Protection: Turn the side underrun protection locking pin (shown) on both sides 180° clockwise or counterclockwise. The locking pin will be locked (1) You may open or close the side underrun protection when the pins are positioned like this. After opening the locking pins, lift the side underrun protection upwards. When the side underrun protection is lifted, return the pins to the locking position (2). After making sure that both pins are locked securely, you may release the side underrun protection.



If the underrun protection is not fixed properly, it may fall and cause injury.

Lowering The Underrun Protection:

Lift the underrun protection slightly upwards, unlock the locking pins and lower the side underrun protection carefully. When the underrun protection is lowered, use the locking pins and fix the side underrun protection.

3.7. Semi-Trailer Axle System

Axle with disc or drum type brake mechanism are used in your vehicles.

Semi-trailer axles may only be loaded with the maximum legally permissible axle load indicated on the vehicle identification plate. The user is responsible for use of the trailer in accordance with its purpose and capacity and for its maintenance.

The healthy operation of the brake system of the semi-trailer depends on the usage of the semi-trailer with the same system and/or compatible tractor. For this reason, it is obligatory for the buyer to make the brake adjustment at the authorized service of the tractor company to which these semi-trailer/trailers are to be matched. If you use the unadjusted truck-trailer combination, the producer doesn't take any responsibility for the damage/failure that may occur in the brake system or vehicles. All responsibility belongs to the customer.



For more information about the axles, please check the axle's user manual which was delivered with your vehicle.



If the axles are used other than the conditions specified in the manufacturer's manual or if their maintenance is not made properly, your vehicle may be out of warranty.



If the vehicle is equipped with emergency brake chambers, apply the parking brake after checking the drum temperature. Never use the parking brake when the drums are very hot (the drum may crack).

3.7.1. Self-Steering Axles

Your vehicle may be equipped with a self-steering axle to increase the maneuverability capacity during forwarding driving. This type of axle is usually positioned at the rear axle of the vehicle and has a locking mechanism.



The turning radius of the vehicle which is equipped with a self-steering axle is different from standard vehicles. In addition, there will be differences in the maneuverability of the vehicle in cases where the self-steering axle is locked or unlocked. Please be careful about the self-steering axles.

3.7.1.1. Locking The Steering Axle

For vehicles with Electronic Braking System (EBS), the self-steering axle can be locked automatically when the reverse gear is engaged in order to reverse. It is also possible to lock this axle manually.

Drive the vehicle straight ahead so that the steering axle is in a straight position before the steering axles will be locked.

If the automatic axle locking function is active in your vehicle, the steering axle

will be locked automatically when you engage reversing gear.

If you want to lock axles manually, make sure that the steering axle is in a straight position and close the valve (1) or turn the button to the off position.

The locking valve will be positioned towards you when the self-steering axle is locked manually.



Reversing with unlocked steering axles is dangerous. The semi-trailer can be separated from the tractor. Before going backwards be sure that self-steering axle is locked.

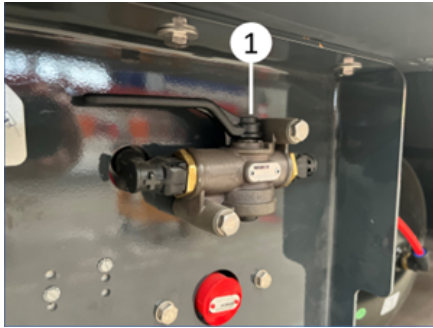

Self-Steering Axle Release Valve

3.7.1.2. Unlocking The Self-Steering Axle

The self-steering axles, which lock automatically when reverse gear is engaged, will automatically unlock when the vehicle is moving forward.

To release the manually locked self-steering axle, turn the valve handle 90° (2) clockwise or move the button to the open position.



When the self-steering axle is locked manually, the axle will not be unlocked automatically. It must be unlocked manually.

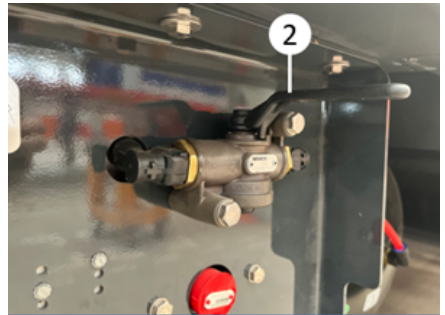

The Self Steering Axles Release Valve

3.7.2. Axle Lifting

Axle lifting feature is optionally available in different quantities and location in your vehicle. Thanks to this feature tire wear is minimized and a more balanced load distribution on the tractor can be provided. The EBS connection must be active for the axle lift load to work.

The axle lifting function is controlled automatically due to the legal regulations. When the speed limit is exceeded and the EBS is active, some axles can be lifted automatically, if the load on the axles is less than the maximum allowable axle load.

The driver may control the axle lifting manually for the maneuvering aid or traction help.



For the active traction help (raising the axle), the vehicle must be slower than 30 km/h and the technical capacity of the axles on the ground must not exceed 30%.

When the trailer is in a park position, you may push the brake pedal 3 times and traction help (axle lifting) might be activated.

If your vehicle has optional axle lifting control from the tractor cabinet, it is

possible to manually lower/raise the axle with a spring loaded button to be installed in the tractor cabin. For this function, your tractor must be adjusted according to the trailer.

It is also possible to activate /deactivate the axle lifting function with a button on the trailer. Traction help can be activated by pressing and holding this button (1) for less than 5 seconds. If it is pressed more than 5 seconds, the axle can be lowered to the ground.

You can also find information about the axle lifting system stickers on the vehicle.

If you change the axle lifting configuration, your vehicle may be out of regulation. For this reason, the EBS modulator should not be checked or repair except by authorized services.

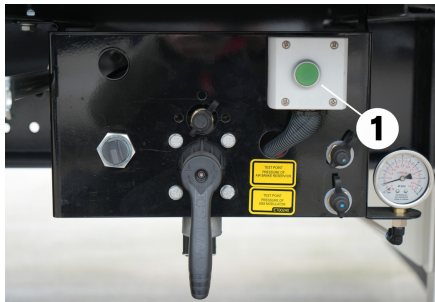



Spring button on the suspension control valve plate



Axle Lifting

There might be a pinching risk during the axle lifting or lowering.



3.7.3. Hubodometer

Hubodometers show the distance traveled by the vehicle in kilometers or miles.

The unit of the hubodometer is written on the hubodometer. It is adjusted according to the tire diameter.



Analog Hubodometer



Digital Hubodometer

3.8. Tires

When you are choosing tires, the first criteria are the load capacity index. Be sure that the load capacity index is suitable for your vehicle.

Tire manufacturers produce different types of tires according to the purposes of their use such as highway use, off-

road or mixed-use. Please choose the correct type of tires according to the road conditions that you will use the vehicle. Choose the low decibel as soon as possible version. Tires as possible as having to Class A fuel efficiency level and braking on wet surfaces according to EU tire label stickers.

 **You can see the EU tire labels of the tires which were used in your vehicle on our website.**

In dual/twin line wheeled vehicles, the tires must be matched properly according to their diameters. The tread depths on the adjacent tires shall not be different more than 5 mm. Furthermore, the newly coated tires and partially worn tires shall not be used side-by-side in relation to the structure and type of the vehicle. Otherwise, driving safety will be disrupted. In such tires, though the tread depths are seen, it must be deduced that the tire diameters are different and the tires exceeding the radius differences by 10 mm must not be used side-by-side.

Wrong matching will lead to excess shape deformation of the larger tire by carrying more load than necessary. In such a case, the wearing will accelerate and reveal the risk of early wearing of the tire. This case must be considered whenever radial and transverse layered tires are used side-by-side.

 **In some countries, M+S (Mud and Snow) or 3PMSF (3 Peak Snowflake) labelled stickers can be mandatory according to season. Please observe the regulations and rules.**



M+S and 3PMSF Symbol

 **Very serious accidents may occur if unsuitable or worn tires are used.**

3.9. Spare Wheel Holder

Different type of spare wheel holders is optionally offered in our vehicles.



Make sure that you put the necessary warning signs and take the safety precautions during the tire change.



Driving with insufficiently secured spare tire (s) can occur accidents.



The tires are heavy parts. Be careful about ergonomics and occupational health and safety rules during the tire replacement. There is a risk of pinching, falling, and cutting.

3.10. Swedish Type Spare Wheel Holder



Spare Wheel Holder

Removing the spare wheel:

- Remove the pin (1) holding the upper retaining ring of the spare wheel holder.
- Remove the pawl hook fixing the spare wheel removal lever from the rings (2).
- Pull back the lowering arm (3) from the slot, released from the hook.
- Lift the holder slightly with the arm and release the top retaining ring from the hook (4).
- After releasing, lower the holder by means of arm slowly downwards.
- Release the arm by removing the pin of nut tightening/loosening arm (5) and pull it backwards and loosen

the nuts by turning them anti-clockwise.

- After loosening the nuts, slide the spare wheel from the stopping pins and take it.

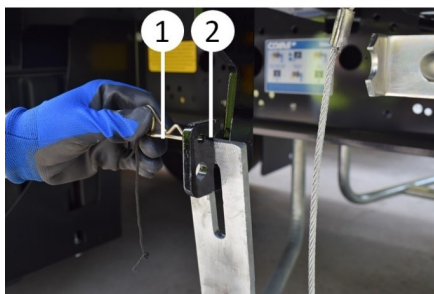

Removing The Spare wheel

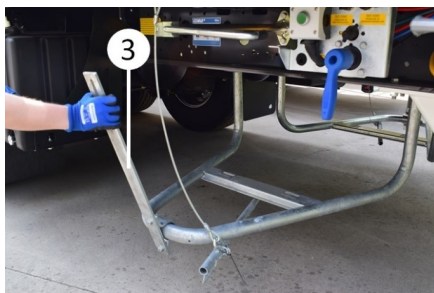

Removing The Spare wheel

Placing the spare wheel:

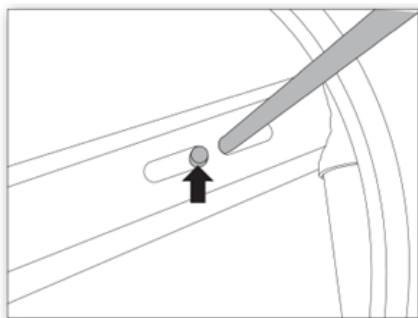

Mounting the spare wheel

- Put the tire onto the holder, position the stoppers to their seats and tighten both nuts by means of nut tightening/loosening arm.

- Then lift the holder with the arm and install the top retaining ring to the hook.
- Push the spare wheel lowering arm into the slot, firstly insert the hook then the top retaining ring and fix it to holder.

3.11. Basket Type Spare Wheel Holder

Single or double basket type spare wheel holders may be optionally provided. Both spare wheel holder working instructions are similar.



Basket Type Spare Wheel Holder

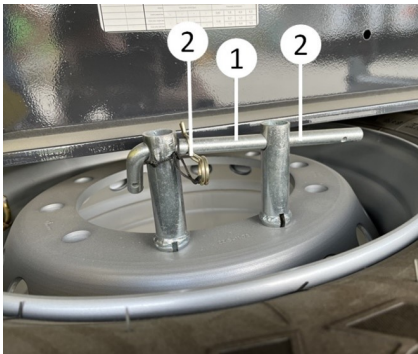

Removing the spare wheel:

- The pin (2) should be removed on the fixation cane (1).
- The fixation cane (1) and the pin (3) will be removed.
- The tire should be slightly moved towards outside of the vehicle.

Placing the spare wheel

- The tire will be slid slightly into spare wheel holder.
- The fixation cane (1) and pin (3) will be attached.
- The pin (2) will be mounted.

3.12. Crane Type Spare Wheel Holder

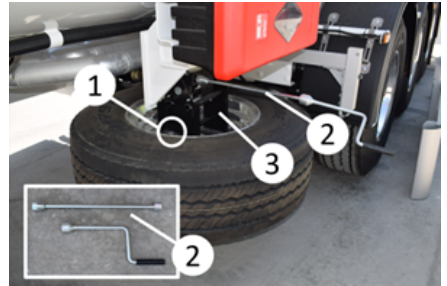

Crane type spare wheel holder

- **Removing the spare wheel:**
- Remove the screws (2).
- Mount the lever (3) and turn it counterclockwise slowly. The spare wheel will be lowered.
- Remove the fixation parts (4) and take the spare wheel.

Placing the spare wheel:

- Mount the fixation parts (4) to the tire.
- Lift the tire upwards by turning the handwheel (3) clockwise.
- Turn the lever (3) clockwise and the tire will be lifted.
- Mount the screws (2) and fix the tire.
- Remove the lever (3) and store in the toolbox or cabinet.

3.13. Mudguards

Your vehicle is equipped with mudguards and/or mudflaps which are suitable for

regulations. The water will be splashed from the ground etc. will be minimized thanks to these mudguards and mudflaps.

Some vehicles may have foldable mudflaps in order to prevent mudflaps from damage. This type of mudflap has to be folded (1) during the huckepack operations.





 **When you are driving, the foldable mud-flaps must be opened.**

3.14. Wheel Chock

There are two units wheel chocks and holders in the vehicle.

 **The vehicle must be secured with wheel chocks when parked on a slope area, during the loading and unloading operations or when parked without a tractor.**

 **Only place wheel chocks on wheels on fixed axles, never on idle/steer axles.**

 **When the wheel chocks is fixed inside the holder, be sure that the pins will be mounted properly.**

 **After driving operations, place the wheel chocks properly.**

3.14.1. Pin Type Wheel Chock Holder

Removing the wheel chock from holders: Pull out the cotter pin (1) located at the end of the wheel chock holder. Then

take the wheel chock from its slot by pulling it sideways from the wheel chock holder.

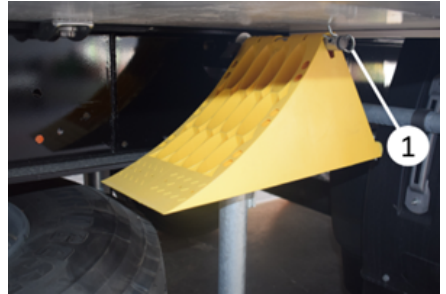

Placing the wheel chock from its holder: Place the wheel chocks on the holders and mount the cotter pin (1) to pin.

3.14.2. Pocket Type Wheel Chock Holder

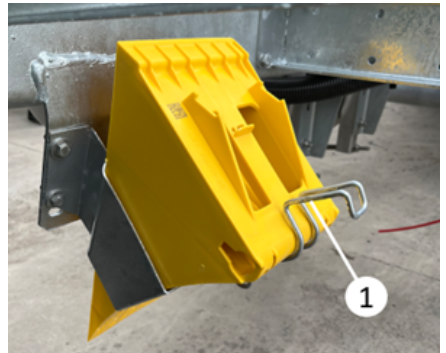

Removing the wheel chock from holders: Remove the wheel chocks by pushing the handle (1) which is located at the end of the chock's holder from the wheel chock to the other side.



Removing the wheel chock from holders:

Placing the wheel chock from its holder: Insert the wheel chock by pulling the handle (1) which is located at the end of the wheel chock's holder.

3.15. Boxes and Storage Units



Be sure that the boxes and storage units are properly closed and that the materials inside of these storage units are fixed properly before driving. Otherwise, the accident may occur.



Be sure that the necessary safety measurements are taken while using the cabinets and storage units.

There are two types of lock systems in the box and storage units.

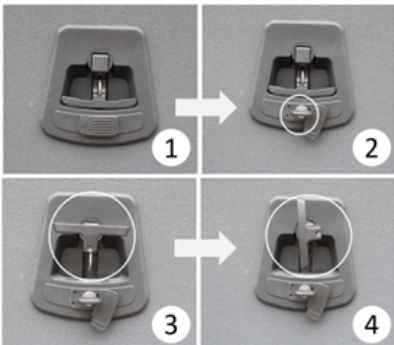

Unlocking the boxes

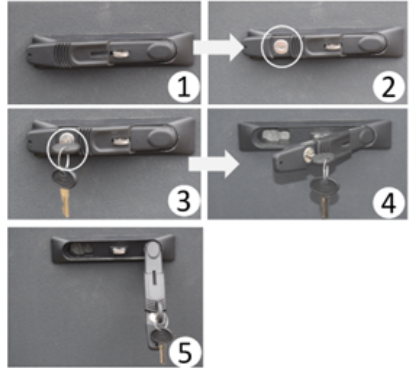

Unlocking the box

3.15.1. Steel Toolbox

Tools and repair sets can be stored in the steel toolboxes. The toolboxes are generally mounted on the driver's side.

Opening the toolbox:

- Insert the key into the lock and switch it to the unlocked position.
- Pull the lock arm back and open the cover by turning it.



Toolbox

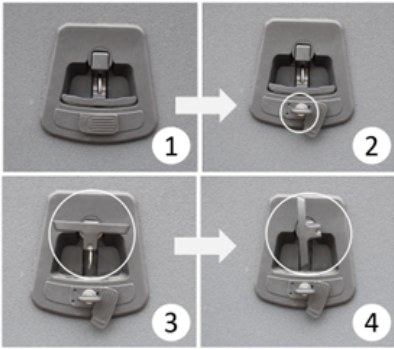

Unlocking the toolbox

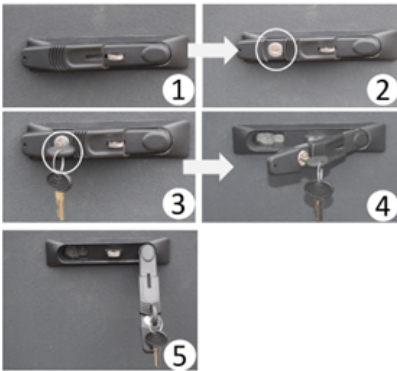

Unlocking the toolbox

3.15.2. Steel Food Box

This type of toolboxes is usually positioned on the passenger side. There might be some compartments and gas cylinders for compartment for cooking.



Steel Food Box

Unlocking the Food box:

- Insert the key into the lock and switch it to the unlocked position.

- Pull the lock arm back and open the cover by turning it.



Steel food box

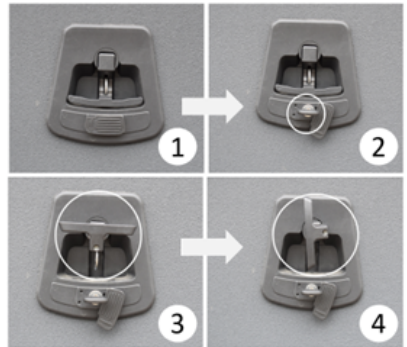

Unlocking steel food box

Some boxes may have a sliding shelf. You can pull the sliding shelf towards you by opening the locking mechanism of the sliding shelf. After the sliding shelf is closed, it must be locked.

Lamps:

The box might be equipped with lamps. These lamps are connected to the parking lamps. When the parking lamps are on, you may push the on/off switch and turn on or turn off the lamps.

3.15.3. Plastic Toolbox



Plastic toolbox



Plastic toolbox

Unlocking The Toolbox:

- Remove the lock cover.
- Unlock by turning the key.
- Pull the lever towards you.
- Turn the lever and open the cabinet door.

3.15.4. Fire Extinguisher Cabinet

Fire extinguisher cabinets are used to protect fire extinguishers from the external environmental factors.



Fire extinguishers must be maintained regularly, and their expiration dates must be observed.



Fire extinguisher cabinet

Opening The Cover:

- Open the 2 plastic latches (1) which are holding the cover.
- Lift the latches up and back and open the cover.
- Remove the re-closable fasteners (black tape) in the fire extinguisher box and take the fire extinguisher.

Closing The Cover:

- Insert the fire extinguisher and fix it with re-closable fasteners (black tape).
- Close the cover first and after that put the latches to the top of the cover.
- Close the latches and lock the cover.

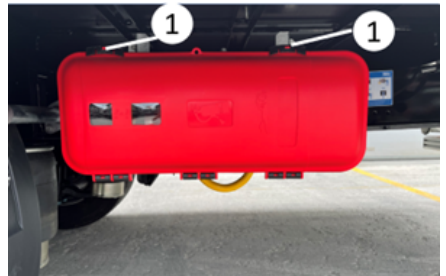

Unlocking The fire extinguisher cabinet





Unlocking The fire extinguisher cabinet

3.15.5. Water Tank

The vehicle may have a water tank for general cleaning purposes. You can turn the tap and open the water. You can fill the water tank with the help of the filling neck which is located at the top of the tank.

There may be a soap dispenser on the water tank. You can disassemble and fill the soap dispenser by turning it counterclockwise.

 Please be careful about the hygienic rules and regulations. The wastewater must be disposed of in accordance with the regulations of the country that you will be in.

 The water in the water tank should not be drunk. It should be only used for cleaning purposes.

 In cold weather, the water tank should be emptied. Otherwise, the water tank may be cracked because of the freezing water.

 The water tank may stop flowing water after a while due to the vacuum effect. To prevent this situation, the soap dispenser must be loosened.



Stainless steel water tank



Stainless steel water tank

3.15.6. Document Box

You may store your non-valuable documentation in the round or square type document box.

You can turn the cover of the round type document box counterclockwise and open the document box.

You may lift the pin of the square type document box and remove the pin. The cover of the square type document box may be opened.



Store the locking pin and the document box cover properly. Otherwise, it might be lost.



Square type document box

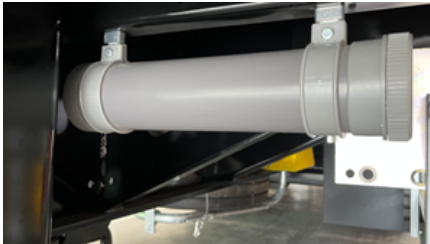

Cylindric type document box

3.15.7. Pallet Box

Wooden or plastic Euro pallets may be stored in the pallet box.

Unlock the pallet box cover. The cover of the pallet box should be slightly slide to down and you may reach the pallet box.



Pallet box

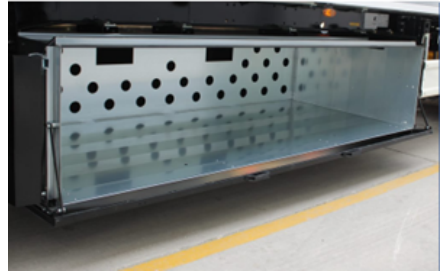

Pallet box



Make sure that the cover will not hit anything when you are sliding the cover.



Pallet boxes can be positioned closer to the ground than other accessories. Please be careful about the pallet box, especially in the rural terrain.

3.15.8. Double Deck Bar Storage Box

Double deck bar storage box, which allows the transportation of double deck bars under the vehicle, is offered as an option.

Unlocking Box:

- Insert the key into the lock and switch it to the unlocked position.
- Pull the lock arm back and open the cover by turning it.
- Pull the lock lever backwards, open the cover by turning the lever.
- When the cover is opened, double deck bars must be regularly stored in the box.



Double deck storage box



Double deck storage box

There is also the possibility of stocking on the front panel and at the rear panel entrance.



Stocking on the front panel

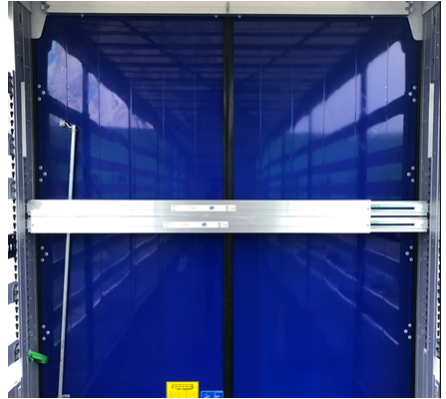

Stocking on the rear panel

3.15.9. Stainless Toolbox

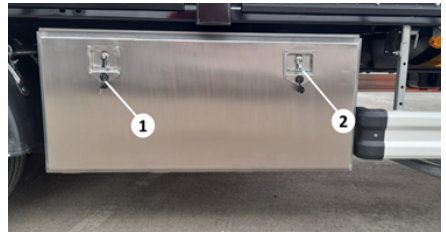

Stainless toolbox

Unlocking The Box:

- First remove/ slide the lock's cover (1).
- Switch the key and unlock the locking mechanism.
- Pull the lever (2) towards you.
- Turn the lever (2) and open the box cover.

3.15.10. Storage For Side Rows

There are side rows storage units on the right and left sides of the axles in order to store the side rows supplied with the vehicle. Capacities are offered as 16 or 24 options.



Side rows storage

Always store side rows in the side rows storage with the thin side down. Always position the lock pin as close as possible to the side rows.

Opening the Side Rows Storage

- The cotter pin (1) is taken out.
- Push the locking pin (2) upwards until it is released from the lower holder.
- Once both sides open, the side rows can be easily removed or placed.

Closing the Side Rows Storage

It is secured by the opposite process.

3.15.11. Pillars Storage

When not in use, you can place the pillars in the pillars storage. Secure the pillars with locking pins and cotter pin.

Always position the lock pin as close as possible to the pillars.

Opening the Pillars Storage

- The cotter pin (1) is taken out.
- Push the locking pin (2) upwards until it is released from the lower holder.
- Once both sides open, the pillars can be easily removed or placed.

Closing the Pillars Storage

It is secured by the opposite process.

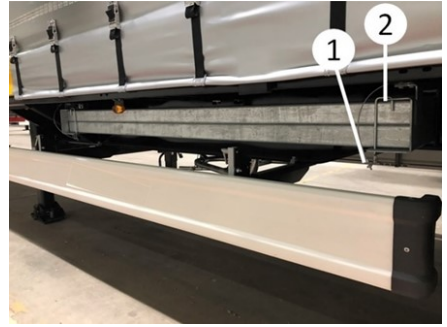

Pillars storage



80 cm pillars storage

3.15.12. Front Panel Storage Box

You can store it in the toolbox built into the front panel. (Available in the standard of paper carrier vehicles.)

- Open the box locks.



Front panel storage box



Front panel storage box



Front panel storage box

3.16. Rear Bumper (Rear Protection Equipment)

Your vehicle has a rear bumper (rear protection equipment) in accordance with legal regulations.



If you drive with a damaged bumper, traffic safety is to be compromised. And if anyone hits your vehicle from the rear side, the size of the accident will be bigger. That's why, the damaged bumper must be replaced with the original one quickly.

3.16.1. Fixed Rear Bumper



Fixed rear bumper

3.16.2. Foldable Bumper

Your vehicle may be equipped with the foldable bumper to use in huckepack, ferry operations etc.

Please pull the fixation pin of the bumper towards you. Lift the bumper carefully and close the fixation pin when the pin and fixation points will be in a line.



Foldable bumper

 For some wagon types of huckepack operations, the bumper must be folded before the loading

 The bumper must be locked and in the driving position in the traffic way.

3.16.3. Ferry Skid

Ferry skids are optionally available to protect the rear bumper, especially at ferry operations.

3.17. Floor

The floor of the vehicle can be covered with phenol resin coated plywood, laminated wood, steel, etc.

For forklift entries into the vehicle, there is a maximum forklift front axle load that has been defined specifically for your vehicle and tested according to a norm. You can see this information from the label on the vehicle or from the sales contract.

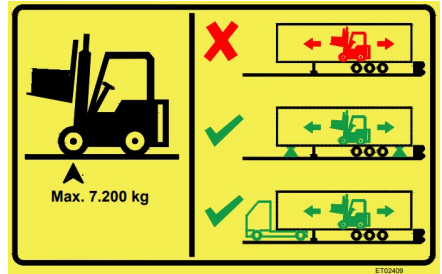

 If a forklift which is heavier than the permitted forklift front axle load enters to the vehicle, the floor may be damaged, and the forklift can be tipped.

 The accident may occur when you are walking on a wet floor.

 In cold weather, there might be ice on the floor. Please be patient about the slipping risk.

 The original spare parts must be used during the floor repair operation. Otherwise, the forklift front axle load might be reduced.

3.17.1. Phenol Resin Coated Plywood



Phenol resin coated plywood

3.17.2. Hardwood Floor



Hardwood

3.18. Ladders

Vehicle may have ladders which allow us to reach some areas of the vehicle more easily.

 Driving with a ladder which is not completely secured has serious hazards. During the driving operation, the ladder may way and injure the people. Use your vehicle with a completely secured ladder.

 Slips from the ladder may lead to accident. Polished, cleaned ladder must be used very carefully. Never use inappropriate means and tools to climb over or climb down the vehicle. Do not jump from the vehicle.

3.18.1. Foldable Sliding Ladder

The foldable sliding ladder (1) is generally located at the rear side of the vehicle and above the bumper. However, the location may vary according to the construction of the vehicle.

Opening of Foldable Sliding Ladder:

- Pull back the ladder outwards from the ring (2) on the fixing pin of the ladder as indicated in the picture.
- Release the ladder from the pin (3) by turning the ring counterclockwise or clockwise.

- Pull out the ladder upwards.
- Break the ladder from the folding point downwards to bring it to the usage position.

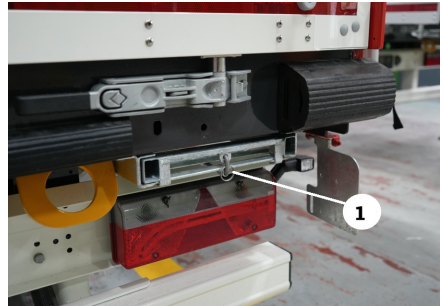

Foldable sliding ladder

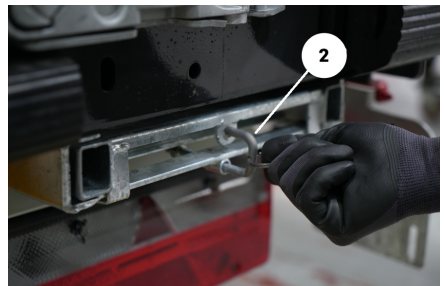

Foldable sliding ladder, removing the pin

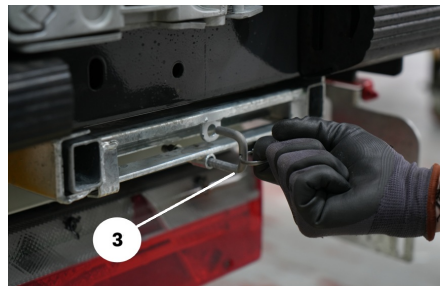

Foldable sliding ladder, removing the pin

 Some of the vehicles may be equipped with a hand grip on the right-side rear pillar. You may enter the vehicle easier thanks to the hand grip.

Closing the Foldable Sliding Ladder:

Upon use of the ladder, fold the ladder upwards and bring it to a straight position and push the ladder into the slide to its location. Pull out the fixing pin from the ring and fix the ladder by turning the pin clockwise or counterclockwise.

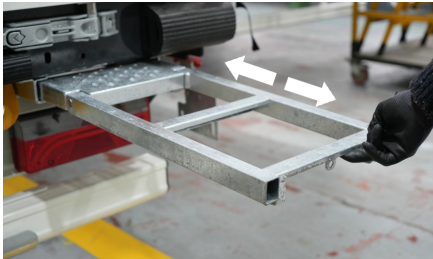

Foldable sliding ladder



Foldable sliding ladder

3.18.2. Ladder in Rear Panel

- The lock pin (1) is taken out.
- The locks (2) opens.



Ladder in rear panel



ilit pini K



3.18.3. Folding Step

2 steps are located to facilitate getting on the platform on the internal section of the rear board of vehicles with boards.

Opening the step: Hold the step from its upper section and slightly pull upwards. After using, fold and close the step.



Step ladder

3.18.4. Rear Board Ladder

Your vehicles with a rear board may have a rear board ladder behind the board.r.



Rear Board Ladder

3.19. Tail Lift

Your vehicle may have different brands and types of tail lifts. Please check the user manual of the tail lift producers for maintenance and usage.



If the tail lift is used or maintained outside the conditions which are specified in the manufacturer's manual, the lift may be out of warranty.



Foldable type tail lift



The tail lift will act like a bumper. That's why the tail lift must be closed properly.

4. UPPERSTRUCTURE COMPONENTS AND USE

4.1. Overview of Trailer Superstructure Components

4.1.1. Curtain Tensioner

It is equipped with different curtain tensioning according to different requests.

- Standard curtain tensioner
- Curtain tensioner with mechanical lock
- Direct tensioner

Standard Curtain Tensioner

1 Tension Strap

2 Curtain Tension Lock

3 Hook

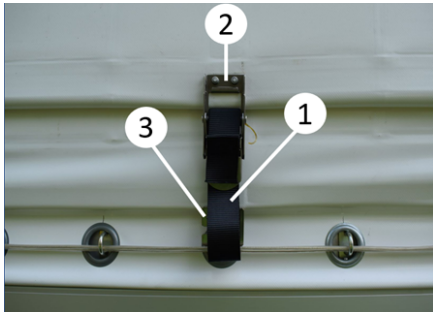

Standard curtain tensioner

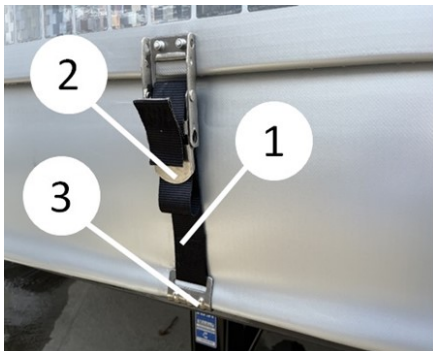

Curtain structure without board

Curtain Tension Opening

- Pull the curtain tensioner (2) lock upwards.
- Pull the tensioning strap (1) down and remove the hook (3) from the outer frame or curtain hooking profile.



Curtain structure with board



Curtain structure without board



Curtain structure with board

Tensioning And Closing The Curtain Tensioner

- Attach the hook of the curtain tensioner to the outer frame or to the curtain hooking profile.

- Set the curtain tensioner to the horizontal position. (90° to the curtain)
- Pull the tensioning strap down and stretch the curtain tensioner another 90°.

Curtain Tensioner with Mechanical Lock

Depending on the options selected in your vehicles, there may be mechanical locking curtain tensioners.

1 Tension Strap

2 Curtain Tension Lock

3 Hook

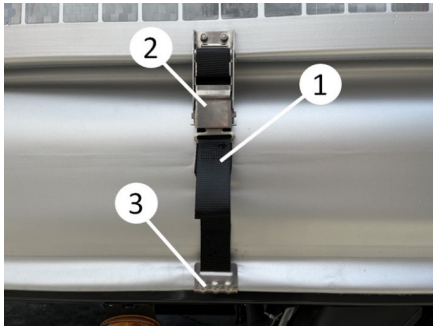

Curtain tensioner with mechanical lock

Opening the Curtain Tensioner with Mechanical Lock

- Grab the tension strap and pull it down



- Remove the hook from the outer frame or board ring after the locking system is unlocked.



Tensioning And Closing the Curtain Tensioner with Mechanical Lock

- Attach the hook (3) to the outer frame or the door hook, then stretch the curtain by pulling the tensioning strap (1), press the lock (2) mechanism to close it and make sure you hear the locking sound.

4.1.2. Curtain Tension

Curtain tensioning is done in two different ways.:

- Rear Tensioning



Rear tensioning

- Front - Rear Tensioning



Front tensioning

Curtain tensioning device is used to tension the side curtain from the front and rear.



In vehicles that will pass through customs, the curtain tensioning mechanism is covered with a pin-fixed cover in accordance with the customs legislation..



Curtain tension cover on vehicle with customs legislation

4.1.2.1. Rear Curtain Tension

- If the vehicle is a customs legislation vehicle, unscrew the customs cable (1) from the cover (2) on the curtain tension mechanism and open the cover.



Custom cable removal



Cover in open position

- By pushing the upper locking mechanism (2) on the curtain tensioning mechanism forward, the tensioning arm (1) is pulled and the curtain profile is discharged.



Curtain tension



Curtain pipe



Fully open location

- The curtain handle (1) is held and the curtain pipe (2) is removed by lifting it upwards.

4.1.2.2. Front Tension



Front tension

- Release the front tensioning mechanism (1) from the lock (2) by pushing it towards the vehicle.

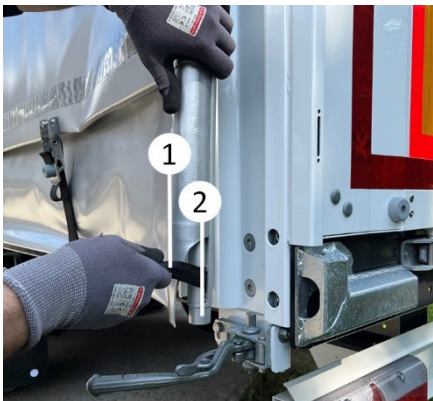

Curtain pipe



Unhooking



Front tension open state

- The curtain handle is held and the curtain pipe is removed by lifting it upwards.



Removing the curtain pipe

4.2. Curtainsider Superstructure

4.2.1. Curtain Structure with Customs Legislation with Board

Components;

- Roof Tarpaulin (1)
- Side Curtain (2)(2)
- Board (3)



Vehicle with customs legislation curtain structure with board

4.2.1.1. Opening the Curtain

- Open the curtain tensioner by following the steps in 4.1.1.



Curtain tensioner open state

- Remove the curtain profile by following the steps in 4.1.2.1.



Removing the curtain profile

- Remove the front curtain profile by following the steps in 4.1.2.2.

- Pull the curtain all the way to the front of the vehicle, holding the handle and the curtain profile at the same time.



It is dangerous to travel with an open, unsecured curtain. The curtain can fly and injure people. Unsecured curtain can also cause cargo materials to fall. Always make sure that the curtains are properly closed and secured before starting to drive.

4.2.1.2. Closing and Tensioning the Curtain

- Pull the curtain gathered at the front back to the rear of the vehicle when you're done.
- At the rear of the vehicle, attach first the upper end of the curtain profile and then the lower end of the profile to the claw and place it in place.
- After making sure that the curtain profiles are fully seated, tighten the ratchet mechanism with the help of a lever until the curtain tension is maximum.
- Fix the customs cover, if any, fit the curtain capsules into the cover hooks.
- Pass the rope through the hooks through the openings on the board and fix it on the hook on the rear door handles.



Openings on the cover

4.2.2. Curtain Structure without Board without Customs Legislation

Components:

- Roof Tarpaulin (1)
- Side Curtain (2)



Curtain structure without board without customs legislation

4.2.2.1. Opening the Curtain

- Open the curtain tensioner by following the steps in 4.1.1.

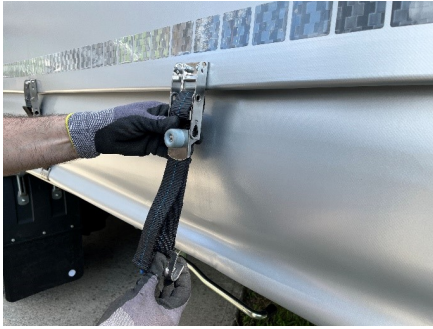

Curtain tensioner open state

- Remove the curtain profile by following the steps in 4.1.2.1.



Removing the curtain profile

- Remove the front curtain profile by following the steps in 4.1.2.2.
- Pull the curtain all the way to the front of the vehicle, holding the handle and the curtain profile at the same time.

4.2.2.2. Closing and Tensioning the Curtain

- Pull the curtain gathered at the front back to the rear of the vehicle when you're done.
- At the rear of the vehicle, attach first the upper end of the curtain profile and then the lower end of the profile to the claw and place it in place.
- After making sure that the curtain profiles are fully seated, tighten the ratchet mechanism with the help of

a lever until the curtain tension is maximum.

- Fix the customs cover, if any, fit the curtain capsules into the cover hooks.
- Pass the rope through the hooks through the openings on the board and fix it on the hook on the rear door handles.

4.2.3. Curtain Structure without Board with Customs Legislation

Components:

- Roof Tarpaulin (1)
- Side Curtain (2)



Curtain structure without board with customs legislation

4.2.3.1. Opening the Curtain

- Open the curtain tensioner by following the steps in 4.1.1.

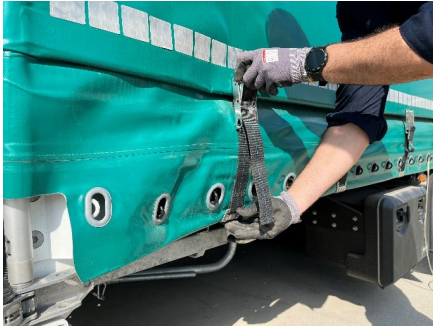

- Remove the curtain profile by following the steps in 4.1.2.1.



- Remove the front curtain profile by following the steps in 4.1.2.2.



- Pull the curtain all the way to the front of the vehicle, holding the handle and the curtain profile at the same time.

Stainless Steel Integrated Vertical Curtain

Curtain pockets are installed on the inside of the curtain. These pockets are fixed by inserting profiles made of aluminum or stainless steel.



Stainless Steel Integrated Vertical Curtain

Anti-Theft Curtain

On the inside of the anti-theft curtains, a wire mesh structure is optionally mounted at a height of approximately 1200,1800 mm from the lower part of the curtain, which makes it difficult to deliberately cut the curtain and provides protection against theft. This structure can also be noticed from the outside and has a deterrent effect.

The functionality of the curtain is not affected.



Anti-theft curtain

4.3. Tarpaulin Superstructure

Vehicles with a tarpaulin superstructure are covered with a single piece of tarpaulin. Breakable type middle pillars are used in tarpaulin vehicles. (4.7.3.2)

Opening the Tarpaulin

1 Locking Strap

2 Custom Cable

3 Rings

4 Hooks



Tarpaulin vehicle structure

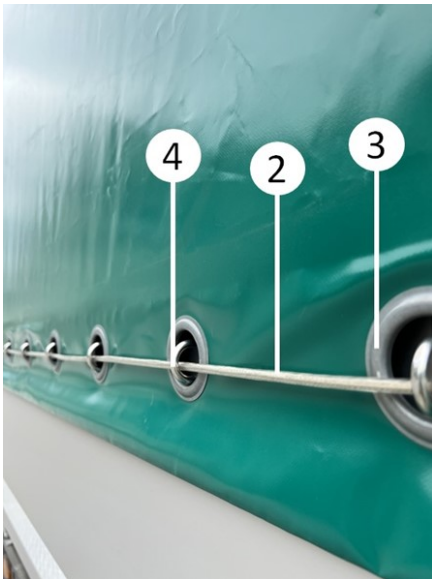

Custom cable and hooks

- Remove the customs cable (2) from under the cover guard and unhook it from the hooks (4). To open one side, pull the customs cable (2) all the way out of the superstructure and collect it on the front panel.

- Remove the locking strap (1) from the hooks (4) by pulling upwards. To unlock from the rear, pull out the locking strap (1) from both sides.
- Throw the tarpaulin onto the awning with a suitable object.

Closing The Tarpaulin



Pull the tarpaulin down from the awning and stand on the side. Watch out for ice build-up or snow accumulations!

- Through the locking strap (1).
- Press the tarpaulin from the hooks (4) to the rings (3) and pass the customs cable (2) through the hooks.
- Secure the customs cable (2) and close the enclosure



Custom rope ends that are not fully fix can cause injuries while driving, rope ends can be thrown and injure people.

4.4. Front Panel

There are two types of front panels in vehicles.

- Steel Front Panel
- Aluminum Front Panel

4.4.1. Steel Front Panel

Steel front panel is formed by combining 2 front pillars and steel panel with rivet connection. On the inside of the front panel there is a supporting plywood structure to protect the front panel from impacts. Two load securing rings used for load securing are located on the inside of the right and left pillars.

There is a coupling plate on the front panel, and there are electrical sockets and air connection couplings on the coupling plate. Optional fire extinguisher box, document box and plates (ADR, TIR, etc.) can be found.



Steel front panel



Aluminum front panel



Plywood construction for protection from impacts



Aluminum front panel interior

4.4.2. Aluminum Front Panel

The aluminum front panel formed of 2 aluminum front bollards and horizontally interlocking aluminum panels fixed to the aluminum front bollards with rivets.

There is a coupling plate on the front panel, and there are electrical sockets and air connection couplings on the coupling plate. Optional fire extinguisher box, document box and plates (ADR, TIR, etc.) can be found.

4.5. Rear Panel

Tirsan Curtainsider and tarpaulin vehicles are equipped with different types of rear panels.

4.5.1. Opening the door

There are 2 types of rear panels that can be used.

- Double hidden lock door
- Container door



The door must always be in the closed position while traveling.



There may be a risk of accident or injury if there is a strong wind or some other factor.

4.5.1.1. Opening the door

There are 2 types of rear panels that can be used.

- Double hidden lock door
- Container door



The door must always be in the closed position while traveling.



There may be a risk of accident or injury if there is a strong wind or some other factor.

4.5.1.1.1. Double hidden lock door

The handle of the door at the bottom of the box is removed from the latch by pulling 90 degrees towards yourself. Afterwards the door handles need to be made parallel to the door again to fix the door to the side panel.



Double hidden lock door



If the door handles are not aligned with the door, damage to the side panel may occur.

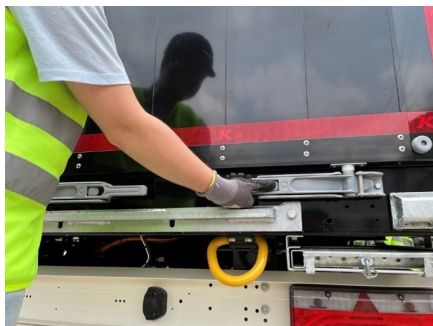

Door lever



Opening the door

4.5.2. Container door

To open the door, the customs cover and/or the protection piece on the door handles need to be lifted.

The door handle is lifted slightly upwards and pulled towards you. After the door is removed from the box, the door handles need to be put back into their place. The customs/protection piece needs to be put back in place afterwards.

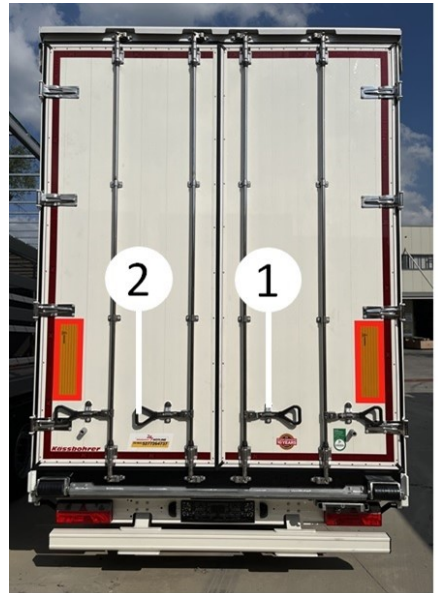

Container door



If the door handles are not inserted into their place or the customs cover is not closed, damage to the side panel may occur.

- The door lock (1) opens.
- The door handle (2) is removed from the socket by lifting it up.



i When the doors open, the right wing opens first. When closing, the left wing is closed first.

4.5.2.1. Rear Board

The rear part of the semi-trailer equipped with tarpaulin is designed as shown.

Opening the curtained rear board

- Untie the customs cable (2) passing through the horizontal tarpaulin rings (1),
- Untie the locking strap (3) that fix the tarpaulin to the rear pillars.
- Open the tarpaulin by throwing it upwards.

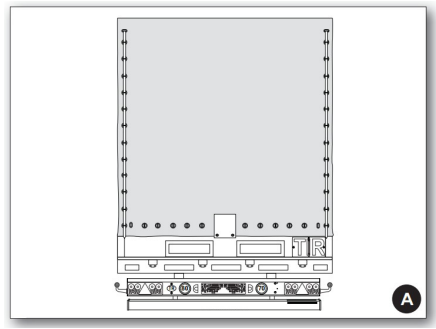

Rear of semi-trailer

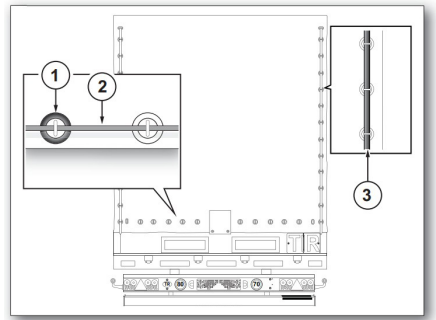

Customs cable threaded through the rings in the tarpaulin

4.5.3. Rear door handle

The rear door handle is used to fix opened rear doors for safety and to prevent damage. They are located just behind the right and left rear wheels.

Fixing the door:

Hold the handle, pull outward in the direction of the arrow (1). Turn it 90° counterclockwise (2) so that it touches the door. At this point the door is fixed.

Unlocking the fixed door:

The arm is kept in its original position by being pulled back from the fixed point and turned 90° clockwise.



Allowing the door to swing back and forth can cause accidents. Always secure the open door with the door handle. Never drive with an open door. Secure the door before departure.



To fix the door in the open position, pull the rear door fastener from a point close to the exit while bringing the door retaining pin to the open position. This will both allow the pin to come out more easily and prevent it from being damaged.



Be careful not to squeeze your hand between the door and the side panel.

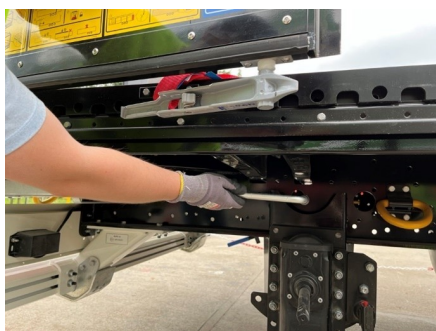

Fixing the door



Fixing the door

4.5.4. Foldable Rear Board



Danger of accident from falling off the rear board. When opening the final lock, hold the board to prevent the rear board from falling suddenly.

Opening the Rear Board:

- Pull out the curtain (tarpaulin) rope from the rings on the rear board.
- From the locks on the rear board, first hold the lock handle and press the safety latch on it.
- Pull the rear board lock lever outwards so that the deadbolt is completely released from its socket.
- Keeping the board so that it does not fall, do the same with the second lock and carefully lower the board.



Traveling with the rear board left open is dangerous and prohibited. An open rear board hides the vehicle's rear lights. This may cause rear-end collisions. Only drive your vehicle with a closed and secured rear board.



Lock lever and safety latch



Lock lever and safety latch

 There is a risk of accident caused by the sudden fall of the side boards. Always hold the side board up by hand to prevent the board from falling suddenly when opening the final lock.

 There is a risk of accident due to loads that may fall from unlocked and/or unsecured boards. Always make sure the boards are secure before you set off.

Closing the Rear Board:

Closing the rear board is performed by following the reverse order of opening it.

Lift the rear board.

Close the rear board locks. Make sure that the safety latches are fully seated.

Removing the Board;

Open the rear board. Slide the rear board to the side, removal of the rear board is only possible in this position. Pull the rear board to the side and remove it.



Locks on the boards

 There is a risk of accident if the rear board is not completely removed. The rear board may fall and possibly injured personnel in the immediate vicinity



Locks on the boards

Mounting the Rear Board:

The board is mounting to its place by performing the reverse of the removal procedure.

4.5.5. Side Boards

The side boards of the vehicle consist of several flaps in each section. There are two locks on each board. Opening the side boards is the same as opening the rear boards.



The open state of the board

4.5.6. Ramp buffers

Ramp buffers prevent the vehicle from hitting the loading ramp or any obstacle damaging the doors or door lock systems while the vehicle is reversing, a ramp buffer can be placed at the rear of the vehicle, just below the doors, depending on the customer's request.



L+T type



L + Section PVC type



Roller type

4.5.7. Forklift Barrier

Forklift barriers; These are plastic or steel protectors placed on both sides of the vehicle to prevent the forklift from damaging the vehicle during loading.



Metal forklift barrier



Plastic forklift barrier

4.6. Pillars

Three different types of pillars are used in the vehicles.

- Rear pillars
- Front pillars
- Middle pillars

4.6.1. Rear Pillars

There are rear pillars made of steel at the rear of the vehicle.



Cables of ceiling lamps or position lamps can pass through the rear pillars. For this reason, it should not be interfered with other than authorized service.



In case of need, the cable and/or air hose may have been pulled from the right rear pillar to the upper part of the pillar so that the vehicle can be electronically locked. These cables have been put in order to make the electronic lock assembly easier.



Rear pillar

4.6.1.1. Openable Rear Pillar

It is the mechanism that allows the rear pillars to expand to 300 mm on the right and 300 mm on the left for loading purposes to facilitate rear loading.

Use of openable pillar:

- Open the curtain and door.

- Open the stop latch on the door upper profile. Open the upper door profile with the help of the roof stick.
- Open the roof forward and stop.
- Remove the side rows.
- Insert the opening lever into the socket in the rear bollard opening mechanism.
- By turning the lever counter-clockwise, the rear begins to expand.
- After loading, close the expandable pillars with the help of an lever and remove the lever from its socket.
- Operate the sliding roof backwards with the help of the roof stick and close the upper door profile.

Close the door after closing the stops of the door upper profile.



Openable rear pillar



Openable rear pillar mechanism

4.6.2. Front Pillars

There are pillars connecting the side panel and the front panel at the front of the vehicle.



Front pillars

4.6.3. Middle Pillars

Two different types of middle pillars are used in vehicles.

- Lateral Pillars
- Breakable Pillars

4.6.3.1. Lateral Pillars

The opening of the sliding pillar:

Press the lever (1) down and pull it out.

Slide the pillar, which we rescued from its socket, on the rail, either forwards or backwards according to our needs.



There is a risk of parts falling out due to unsecured pillars. Only travel with fully secured pillars. There is a danger of accident due to the pressure exerted by the burden on the pillars while the pillars are untied. Be extremely careful when solving pillars.



In order for the pillars to slide or break, the side rows and side boards must be removed.

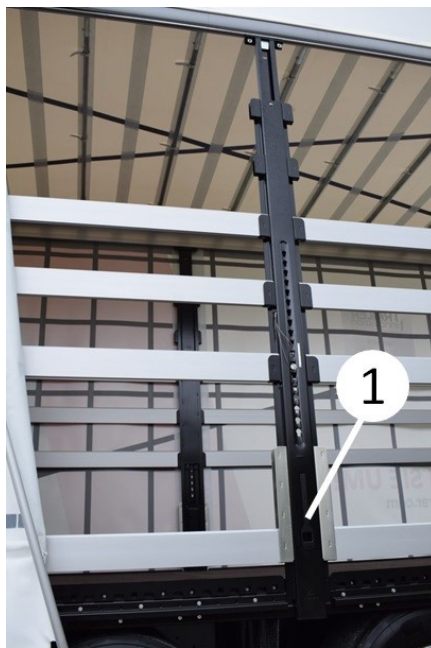

Sliding pillar



Unlocking the sliding pillar

Closure of the sliding pillar:

- First, fit the pillar into the socket.
- Push the stem inward until the latch in the ring is fully engaged.

Complete removal of pillar's sleds:

- The pillars can be completely removed from the vehicle by means of the two skid spaces on the left and right at the front of the vehicle.

4.6.3.2. Breakable Pillar

Opening the Breakable Pillar;

- By pressing the latch (1) located at the top, pull the lever (2) towards you approximately 90°, while the upper tab is released from its socket.
- Then press the lever again to release the lower tab from its socket.
- After the tabs are freed, you can break the pillar by pulling it out of the vehicle.



During travel, roof supports and curtains can be damaged by incorrectly placed pillars.

Closing the Breakable Pillar;

- Straighten the broken pillar.
- Gradually lift the lever that is pressed down and engage the tabs in their sockets.

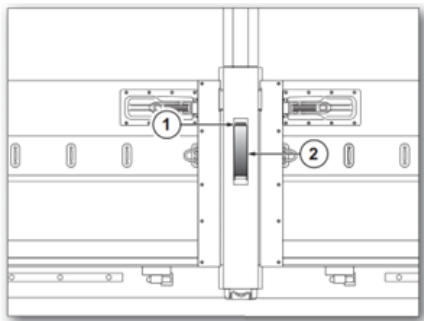

Latch and lever on the pillar

4.7. Side Rows

Side rows are structural elements that support the sides of the vehicle and provide side support for the curtain. They also prevent the load from falling while cruising. Although the units varies according to the configuration of the vehicle, it is definitely given with the vehicle.

- Aluminum side rows (V type and box profile)
- Wooden side rows
- Steel side rows



If necessary, three of the side row elements can be used as a side support structure by placing them on top of each other.

Removing the side components from their socket:

To remove the side member, lift the member from both sides at the same time and free it from its sockets.

Placing the side rows in the socket:

To insert the side row into the socket, first gently insert it into the socket from one side and then insert it into the socket from the other side.

4.7.1. Aluminum Side Rows

There are two types as V type and box profile type. V-type aluminum side rows are used on vehicles without board. It can act as a board with its ability to be mounted on top of each other.



Box profile type aluminum side row



V type aluminum side row



V-type aluminum side rows mounted on top of each other

4.7.2. Wooden Side Rows

Depending on the vehicle characteristics, your vehicles may have wooden side rows.



Wooden side row

4.7.3. Steel Side Rows

Your vehicles may have steel side rows. It has a hole structure.



Steel side row

4.8. Roofs

Basic Components

- Sliding roof
- Lifting roof

4.8.1. Lifting Roof

Vehicles may be equipped with a roof lift system. The vehicle has a roof lift use label inside the rear panel.

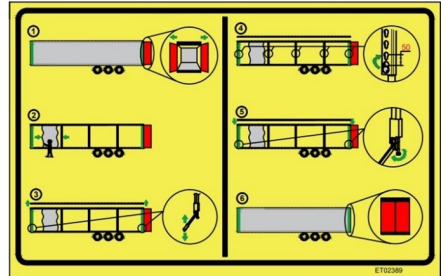

Roof lift use label

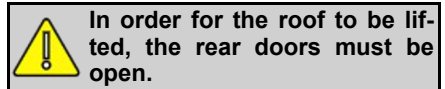

It provides the opportunity to increase the internal height of the vehicles by +500 mm during loading and to travel up to +200 mm internal height while cruising.

Basic Components

- Mechanical roof lift arm
- Roof lowering button
- Roof lift level adjustment bar

Lifting the Roof:

- For lifting, hold the lifting arm, which is available on all 4 pillars, by the end and raise the roof by pushing and pulling it back and forth with the jack arm logic.
- Do this separately on all 4 pillars.



Traveling with a raised roof for loading is dangerous. The roof must be lowered while traveling.



The roof can be lifted a maximum of 500 mm for loading purposes. By changing the rear panel upper profile, it may be possible to travel with an increase in height up to 50+50+50 mm, if desired.



Roof lifting pump



Roof lifting lever



Roof lift level bar



Roof lifting

Lowering the Roof:

After putting the roof lift arm in place, press the button (1) located in the opening in the middle of the lever inward, allowing the raised roof to come down. The rate of the roof descending is proportional to the amount of you press the button.

Stopping:

The stop is available on all roof lift arms. It can be adjusted to the desired level with the allen key.

 **There is a risk of accident during roof lifting operations other than those described.**

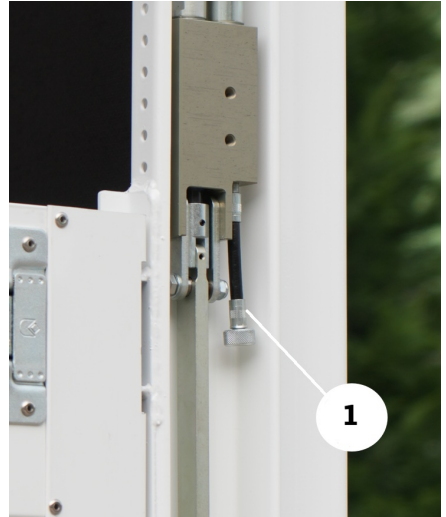

Button located in the opening in the middle of the arm

Read the following instructions carefully for safe roof lifting and personal safety;

- It is forbidden to drive the vehicle with the roof raised for loading purposes!
- Only use your vehicle with the roof properly lowered or raised for travel purposes.

During the lifting of the roof, the following rules must be observed;

- There should be no load or weight (ice, snow, etc.) on the lifted roof.
- When the roof is to be lift in closed areas, at least 600 mm of free space should be left on the vehicle.
- It should be ensured that all safety devices and locks are properly applied on the raised or lowered roof.
- The raised roof must be lowered immediately after loading / unloading.

Before each ride;

- Snap the roof lift arm fully into place.
- Lock the curtain tensioner.



The superstructure, tarpaulins and curtains may be damaged due to the rear panels and curtain tensioners not being fully opened prior to the operation to lift the roof or change the superstructure height. Therefore, before the roof lifting operations;

- You have opened all the tarpaulin / curtain tensioners,
- Make sure you keep the rear panels open.



Roof lift pump



Curtain tension lever

4.8.2. Sliding Roof

There is a sliding roof usage label on the right interior rear panel of your vehicles.

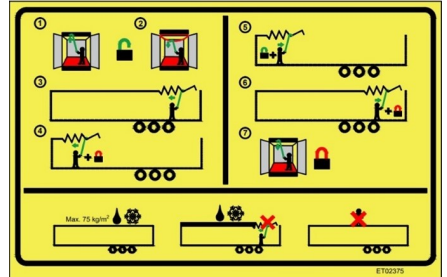

Sliding roof usage label

4.8.2.1. Basic Components

Sliding roof pull cane: The sliding roof pull cane is used to slide the roof. It is kept fixed to the inside of the rear panel. Its location may vary depending on the vehicle construction.

Roof rail (Profile): Two different roof rails are used in curtainsider vehicles. In the vehicles with tarpaulin, a roof profile is used instead of a roof rail.

Front console: It is used to connect the right and left roof rails to each other at the front of the vehicle.

Rear console: It is used in the connection of the right and left roof rails with the rear pillar.

Rear panel upper profile: Sağ ve sol arka babanın üst kısmında birbiriyle ve çatı ile bağlantısını sağlar.

Sliding roof: Two different types of sliding roofs are used:

- Sliding roof that opens on one side
- Double side sliding roof

Opening the Sliding Roof:

- The rear panels open



Opening the door

- The sliding roof pull cane on the right rear panel is taken.



Sliding roof pull cane

- The length of the sliding roof pulling cane is taken to the desired level.



Sliding roof pull cane lock pin

- Lift the top of the rear panel profile by pushing it from the bottom with the roof cane.



- Then, pull the steel rope towards the front of the vehicle by means of the sliding roof pulling cane so that the deadbolts on the right and left parts get rid of the stops.



Sliding roof from outside



Sliding roof

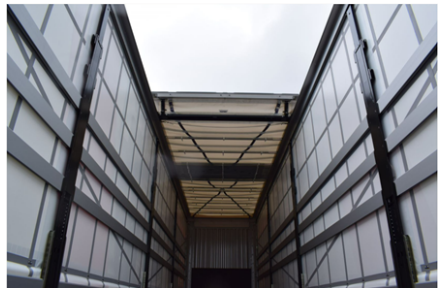
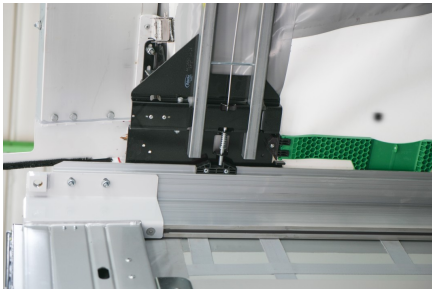

Sliding roof

- Attach the sliding roof pull handle to the metal ring on the roof or to the green roof sliding rope on the outside of the vehicle and pull it towards the front of the vehicle.



The steel rope is only for the release of the deadbolts from the stops. Do not slide the roof by pulling on the steel rope. The pulling operation should be carried out by holding the ring on the iron part.

Closing the sliding roof:

- Engage the latches on the stops by pulling the roof from its front position towards the rear of the vehicle.
- Grab the ring in the middle of the upper profile and pull it downwards.
- Fix the profile by turning the pins on the profile 180° counterclockwise.

4.8.3. RSAB

- With vehicles designed for coil material transport, offers possibilities for securing roll materials
- The RSAB system is exclusively designed for indirect use on trucks, trailers and semitrailer tarpaulins to prevent the formation of puddles and ice sheets. Any other use is improper. The manufacturer is not responsible for any damage caused by this. The risk is borne solely by the user.
- The RSAB system does not exempt the driver from liability. As part of the prejourney checks, the driver has to check his vehicle for water, snow and ice sheets.
- The system acts in a preventative manner and prevents the accumulation of water on the tarpaulin and thus the subsequent ice build up. Always activate the system during long periods at a standstill to prevent such water accumulation!

There is a control unit on the front panel.



RSAB control unit

- By pressing the button on the RSAB control unit, the hose fills within approximately 4 minutes after which the system turns off again. To evacuate (bleed) the RSAB hose, press the button or operate the brake. To bleed or evacuate the system the tractor must be coupled and the parking lights turned on.

Safety Instructions

Please note that, in any case, when the RSAB hose is activated, the total height of the vehicle changes.

Before driving off the air hose must be evacuated by pressing the button or operating the brake, to ensure that you do not exceed the legally prescribed vehicle height of four metres. Never drive off with the RSAB activated!



RSAB

5. TRANSPORTATION PROCESS

5.1. Sürüş Öncesi Kontroller

- Gerekli tüm dokümanların araçta bulunduğunu,
- Gerekli ayarlamalar ve yükleme durumunun uygunluğunu,
- Araçın, çekiciye uygun olarak bağlanmış ve emniyete alınmış olduğunu
- Araç ve çekici arasındaki tüm pnömatik ve elektrik bağlantılarının gerektiği gibi yapılmış ve EBS sisteminin çalışır durumda olduğunu,
- Tüm yapı donanımlarının (takozlar, bisiklet korkuluğu, merdivenler vs.) Yerlerinde ve gerektiği şekilde kilitlenmiş ya da emniyete alınmış olduğunu,
- Sürüş sırasında yüklerin yer değiştirmesini önlemek için doğru bir şekilde emniyete alınmış olduğunu,
- Yük ağırlığının izin verilen sınırlar içerisinde olduğunu,
- Bulduğunuz ülkenin regülasyonlarına uyulmuş olduğunu,
- Aydınlatma ve sinyal sisteminin tam olarak çalıştığını,
- Lastik hava basınçlarının gereken seviyede olduğunu,
- Semi-treylerin el freninin çözülmüş durumda olduğunu kontrol edin.

5.2. Semi-Trailer and Tractor Coupling

Apply the following steps to couple the semi-trailer with the tractor:

- Check that kingpin and its couplings are normal . Make sure that there is an adequate amount of grease oil on the fifth wheel, top-connection plate and kingpin that will prevent damage when coupling and that it

does not contain any dust and contaminant.

- Lower the height of the rear suspension airbags of the tractor until it can be inserted in the king pin section of the semi-trailer.
- Set the 5th wheel locking system on the tractor to the "On" position.
- Adjust the height of the semi-trailer to insert it into the tractor. The height of the semi-trailer can be adjusted with the mechanical landing gear. Prevent the movement of the semi-trailer by using the parking brake. Put wheel chock at the rear of the wheels for safety.
- Move the tractor, fifth wheel until it touches the top-connection plate of the semi-trailer and moves backwards slowly on the same level. The fifth wheel will slide smoothly under the top-connection plate and enter the kingpin's shoes and lock automatically with the intensity of impact.
- Raise the landing legs of the semi-trailer and insert the landing legs arm to its place.
- Connect the air, electrical and EBS cables and hoses to their places on the tractor. Be sure that all the functions are working properly.
- If the vehicle has a parking brake, release the parking brake.

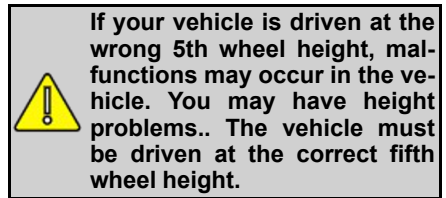

Apply the following steps to uncouple the semi-trailer with the tractor:

- If the vehicle is equipped with service type brake chambers, apply the

parking brake after checking the brake drum. Never apply the parking brake when the brake drums are very hot. (The drum may crack.)

- If the vehicle has a hand-brake type brake, put a wheel chock in front of the vehicle. Apply the handbrake.
- Disconnect the brake air lines, the brake will be applied automatically. Disconnect the semi-trailer electrical connections.
- Lower the mechanical landing gear of semi-trailer (use high speed). When the mechanical landing gear feet or wheels touch the ground, switch the mechanical landing gear crank handle to low-speed position to raise the semi-trailer.
- Unlock the fifth wheel lock. Separate the tractor from the semi-trailer about 500 mm by slowly moving the tractor forward. Lower the level of the rear suspension airbags of the tractor and leave the semi-trailer's bottom.



To ensure that that the king pin is locked properly, engage the first gear of the tractor, and press the gas pedal, when you are slowly releasing the clutch, you will feel that the tractor strives to move the semi-trailer, this indicates that the connection is made properly. During the travel, this connection must be checked carefully to prevent separation of the semi-trailer from the tractor accidentally.

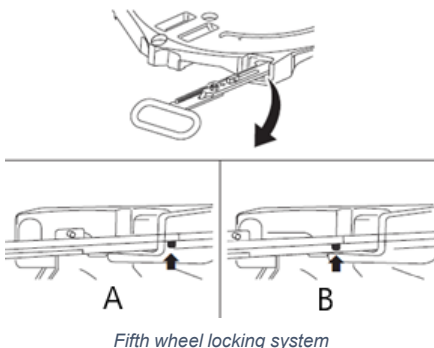

A- Locked

B- Unlocked

5.3. Cautions During the Parking and Stopping

- Involuntary trailer movements, unstable posture and insufficient safety at night may occur serious accidents and injuries.
- Use the parking brake and wheel chocks while stopping.
- If you are going to park the vehicle in a public traffic area, you must use the necessary marking plate in accordance with legal regulations.

5.4. Important Technical Considerations

5.4.1. Fire Extinguisher

Please check fire extinguishers periodically every year and fill them up if

necessary. In case of any usage of the fire extinguishers, fill it up immediately.

Precautions to be taken in case of fire:

Some sealing materials let out gas when burned and these gases may become abrasive acid in contact with water. Thus never touch the fire extinguisher liquid accumulations without wearing protective gloves.



Fire extinguisher box

5.4.2. Wheel Chocks

Keep the wheel chocks in their place and place them under the wheels during parking. Do not forget to remove the wheel chocks before setting off.

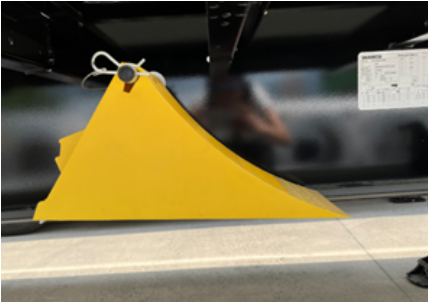

Wheel chocks

5.4.3. Treylerde Yapılacak Değişiklikler

Treyler üzerinde yetkili servis dışında herhangi bir işlem yapılmamalıdır, Treyler'e yetkili servis dışında yapılan değişiklik/tamiratlarda araç garanti kapsamı dışına çıkar.

5.4.4. Air Leakage

In case the air pressure in the air tubes drops instantly with the engine stop, this means that there is a leakage in the pneumatic system. Contact the nearest authorized service in such a case. The air leakage not only affects the safety of the braking system but also negatively affects the load lifting capacity of air-bags.

5.4.5. Considerations For the Environment

Pollution in all its forms poses a threat to the environment. To keep the pollution at a minimum, collect the waste materials carefully and dispose of them in accordance with the regulations of your country.

ENVIRONMENT - Disposal of the battery in an inappropriate place may harm the environment and human health. If you need to dispose of the battery, follow local regulations. If you do not know how to dispose of it, take it to the most appropriate service point. The symbol on the battery indicates that this product should not be disposed of.



Health and Safety

- Keep sparks and fire away from the battery. The battery emits explosive gas that can cause an explosion.
- Wear eye protection and rubber gloves while working on the battery, otherwise the battery hand-control may cause burn and serious damage including blindness in your eyes.
- Under no circumstances allow children to handle the battery. Make sure that anyone dealing with the

battery is familiar with the proper use of the battery and its hazards.

- Pay close attention to the battery electrolyte as it contains diluted sulfuric acid. Contact with your skin and eyes may cause burns or loss of eyesight.
- Carefully read and understand this manual before working on the battery. Failure to follow instructions may result in injury and vehicle damage.
- Do not use the battery if the electrolyte level is at or below the recommended level. Using the battery with a low electrolyte level can cause explosion and serious injury.

If there are wasted oil and wasted oil contact materials in your vehicle, pay attention to the following warnings.

When disposing of products/wastes such as used oil, hydraulic oil, do not discharge into channels, sewers, landfills, or soil. This is against the legislation of all countries.

This rule also applies to empty containers in contact with oil, chemical materials, and waste of cleaning cloths. Take these wastes to the relevant authorities or the most appropriate service point for disposal.

If your vehicle tire has expired;

The end-of-life tire must be disposed of in accordance with the regulations. For this, take your expired tire to the relevant authorities or appropriate service points.

If you carry dangerous chemicals in your vehicle;

In case of an accident or emergency that may occur during transportation, act in

accordance with the Written Instructions of the ADR Legislation.

From the trailer's life-cycle perspective, it is important to recycle the end-of-life vehicle in an environmentally friendly manner. A large part of the trailer consists of recyclable materials. Contact the approved company and appropriate service for the recycling of the trailer that has expired.

5.4.6. Cleaning the Vehicle

Before starting to clean the vehicle, check the hub and axle lifter for leaks. These may not be visible after the cleaning process is complete. Pay special attention to the following when washing with pressurized water:

- Do not hold the hose nozzle directly to the felts while washing with pressurized water.
- Do not hold pressurized water to the electrical components and connections of the vehicle.
- The vehicle should be washed by holding a maximum 240 bar pressure washer at a minimum distance of 1 m and at a maximum angle of 45 degrees in order not to damage the vehicle logo and paint.
- After cleaning the vehicle, carefully lubricate the greasing points with a grease gun. This is important to prevent dirt and moisture from entering various parts of the vehicle.
- Clean the interior and exterior of the vehicle every time you return.

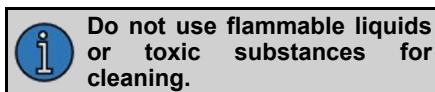

6. TRANSPORTATION SOLUTION

6.1. Coil Material Transport

With vehicles designed for coil material transport, offers possibilities for securing roll materials.

6.1.1. Coil Transport Well

A "V" shaped groove has been added to the vehicle superstructure floor so that the coil-shaped loads can be safely transported inside the vehicle without shaking, tipping over. This groove is called the coil transport well.

Using the coil transport well:

- There is a loading label on the rear panel. Determine the position of the coil load in accordance with the values on this label.
- Lift the boards in the area where the coil will be placed.
- Place pillar profiles if needed.
- Place the load.

Removing the coil transport well from use:

- Remove pillar profiles, if any.
- Place the boards.

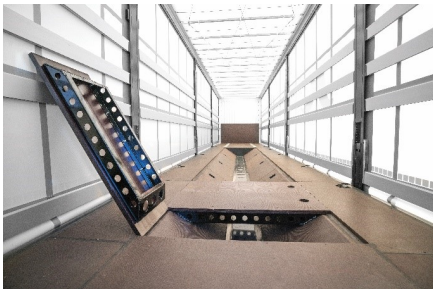

Coil transport well boards



Risk of accident due to slipping and/or tipping of load parts. The front panel, rear and side boards of the loading compartment, including the rear panels, are made to withstand the extreme force of heavy loads that begin to slide under the influence of external forces, up to a certain limit. Therefore, effectively secure loads against slipping and tipping over.

According to the number of coils to be transported, lift the required number of coils carrying chamber board. Uncover the coil transport well. Carry out the loading process of the coils, taking into account all laws, rules and regulations.

The coils are loaded in the coil well in the direction of travel (with the centerlines of the coils parallel to the centerline in the direction of travel of the vehicle).



Risk of accident due to unprofessional loading of the coils. The coils can slide or coil out of the chamber they are in. Before setting off, make sure the coils are fully inserted and secured in the well. Transport the coils only with “Coil Transport Well” vehicles.



Coils that can be transported in your vehicles; minimum diameter: 900 mm and maximum diameter: 2100 mm. Coil loads must be tied in accordance with EN 12642 with mooring ropes suitable for the coil tonnage. The coils should be placed so that they rest against the pillars.



Driving with overloaded vehicles can cause serious traffic accidents! It also causes great damage to the semi-trailer and tractor and reduces its life.



Overload; It has bad effects on steering, braking and speed control. Overloaded vehicles drive slow on slopes. On the contrary, they gain more and more speed on downhill descents. This will increase the stopping distance.



It may not be safe to drive with the maximum allowable load in bad weather and mountain passes. Take this into consideration before driving.

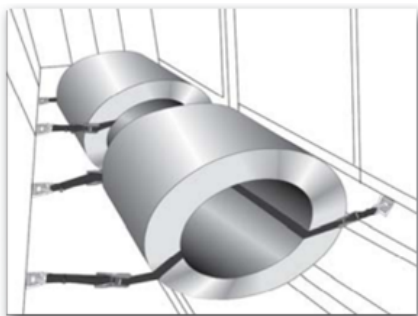

Safety of coils

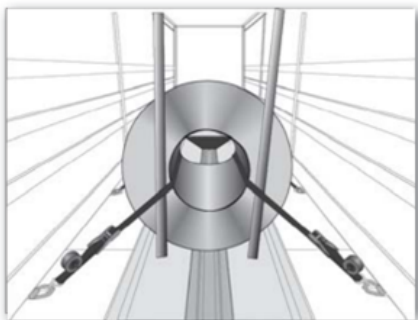

Safety of coils

6.2. Air Cargo Transport

The roller system is specially designed for air cargo pallets transportation. In order to provide easier loading/unloading operations, the floor contains a roller system. A Roller system is a pressurized air system and is divided into sections. Optionally, these four sections can be lifted and lowered by means of the control panel independently.



Air Cargo Roller Floor

6.2.1. Roller Control Panel

The control box is located on the chassis back side.



Roller control panel

There are 4-unit control buttons, 1 unit reset button, a roof lights control button and 1 unit air manometer in the control panel. Functions such as the lifting and lowering of the roll sections, air discharge and the system's pressure value check can be made via this control panel.

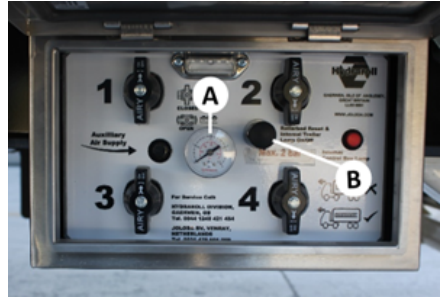

Air manometer and reset button

Air Manometer (A): It shows the pressure of the system as a BAR.

Reset Button(B): Thanks to this button, you may reset the system. Pull the button and the system will be reset.

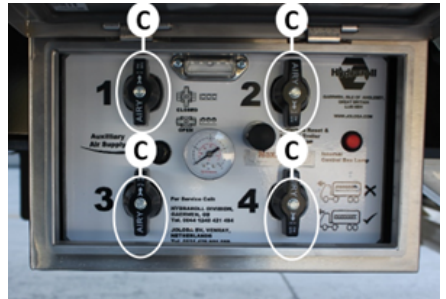

Buttons

1, 2, 3 and 4 number buttons (C): These buttons are used to raise the four roll sections of the vehicle independent from each other. When you want to use one of the roll sections, switch the button of the relevant section to the ON position. Upon completion of the loading, switch the button to the OFF position and lower the rolls.

 **Do not drive with raised rollers.**

 **Before lifting the rollers, make sure that the vehicle is in a level position, otherwise the load may slip and cause injury.**

There might be 4-unit quick release valves on the vehicle. Thanks to these

valves, the air in the rollers will be discharged quickly and reduce the operation time.



Quick release valves

As an extra safety function, your vehicle may be equipped with an auttdown function. When your un-brake the vehicle, rollers will automatically go down. You must reset the system when you use this function.

 **The auto-down function is only an extra security solution. The operator must lower the rollers after each loading/unloading operation.**

 **Do not step on the rollers while walking inside the vehicle and during loading/unloading operations. It may cause injuries.**

 **Your vehicle's interior lights may be connected to the button in the roller control box. In this case, you can control the interior lights with this button..**

6.2.2. Pallet Stoppers

To prevent the slipping of the air cargo pallets inside the semi-trailers during the transportation, there might be a pallet stopper system on the floor.



Closed pallet stoppers

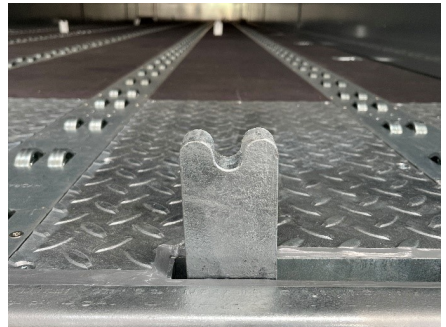

Open pallet stoppers

These pallet stoppers can be lifted upwards to quickly fix air cargo pallets.

You may pull and raise the pallet stoppers and fix the air cargo pallets quickly.

When you pull the open pallet stoppers a little bit up and move to the side, the pallet stopper can be closed.

 **Give attention to pallet stoppers while you are walking inside the vehicle and during loading/unloading operations.**

6.3. Load Transportation with Double Deck

Double deck transportation is optionally offered for the transport of pallets at low height, and which cannot be carried on top of each other.



Do not carry more than 700 kg in the 1 meter long area along the side panel and a total of 10,000 kg on the double deck rails. If the average pallet weight is 280 kg, the load will be distributed uniformly.

The vehicle side panel may have vertical double deck rails for transporting a certain type of pallet (usually Euro pallet).



You can put the pallets that you will carry on the second floor on the profiles by taking the profiles with the rails attached to the desired height. Profiles must be parallel to the ground. Otherwise, the load may tip over.

You can use the handle to move the profiles upwards.

To slide the profiles downwards, the latch on the lower side of the profiles must be pushed. When this latch is pushed, the profile will slide down.



Profiles with loads on them should not be moved.

6.3.1. Using the Double Deck System

Technical Definitions:

Double Deck System;It is a special system used for the transportation of pallets or closed goods with vehicles with two loading levels, whose superstructure is specially designed.

- Longitudinal Beams (12 Units)
- Rail Bearings (24 Units)

- Load Beams (24 Units)
- Vertical Rails (14 Units)

Load Dependence of Longitudinal Beam Length

The maximum pallet weight must not exceed the declared weight on the longitudinal beams. Appropriate loading values of longitudinal beams are given in the loading diagram shown on the right.



As the length of the beams increases, their carrying capacity decreases. It has a carrying capacity of 400 kg up to 2.5 m in length. Carrying capacity decreases by 100 kg for every 50 cm after 2,5 m

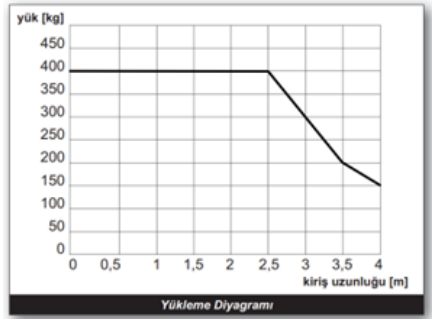

Loading diagram

6.3.2. Safety Instructions

- Before the installation and use of the double-deck loading system, carefully read the user manual and load in accordance with these rules.
- Do not load without making sure that the double deck profile tips are fully seated. The profile may become dislodged and cause serious injury or damage.
- Make sure that both ends of the double deck profile fit into the opposite holes and are parallel to the floor. Otherwise, you may damage the movable mechanism while removing the profile.

- Make sure that the load on the second floor is fixed.

6.3.3. Proper Terms of Use

The user manual should be read carefully for the proper use of the double deck loading system.

Double deck loading system and its parts only.

- Read the double-layer loading system guide,
- Traffic Regulations,
- Traffic Compliance Regulation,
- Should be used by people who have knowledge of Load Safety in vehicles.



Comply with accident prevention regulations, laws, safety instructions, traffic regulations.

6.3.4. Dangerous Situations

- The application of the double deck loading system is only possible with the original load beams and with appropriate length settings.
- In partial loads, additional safety measures should be taken to prevent the load from slipping and falling (tow, beam, etc.).
- To keep the vehicle's center of gravity low, the upper floor should only be loaded if the lower floor is fully loaded. If the pallet weights are variable, light pallets should be placed on the upper floor and heavy pallets should be placed on the lower floor.
- Users should note that the total center of gravity of the vehicle varies depending on the loaded condition. This change in the center of gravity affects the roll stability of the vehicle.

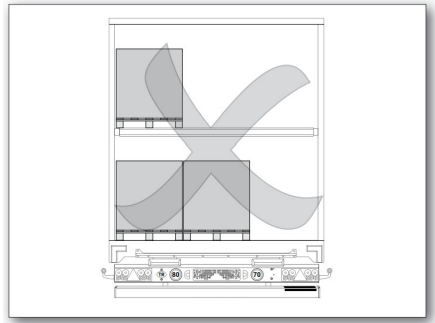

Non equal divided freight

6.3.5. Loading the Vehicle

Loading Order of Lower Floor

1. First and second pallet
2. Third Pallet

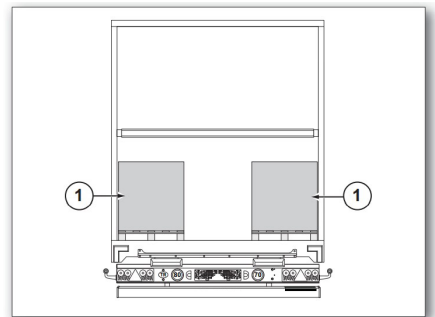

2 pallet lower floor

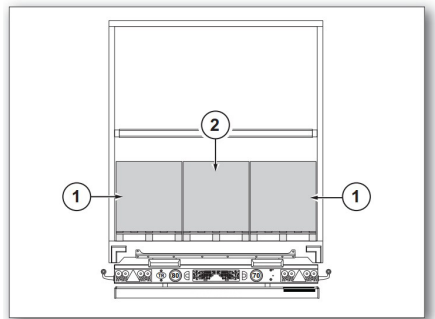

3 pallet lower floor

Loading Order of Upper Floor

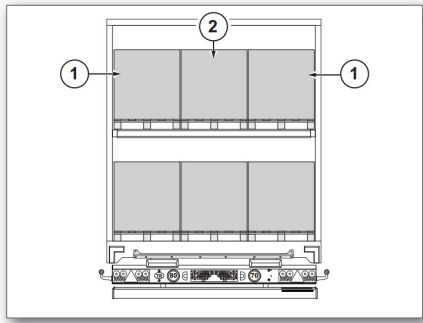
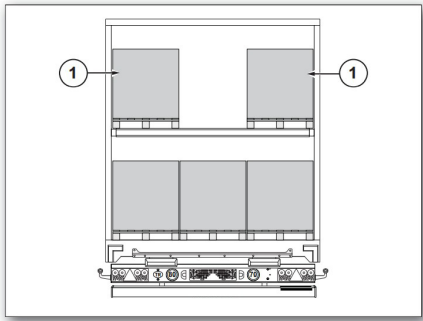

6.4. Paper Transport

Paper rolls are placed on the wedges and fixed with spanzet in the paper transport vehicle, which is designed for the safe transport of roll-shaped papers. The operating instructions supplied with the vehicle should be studied.

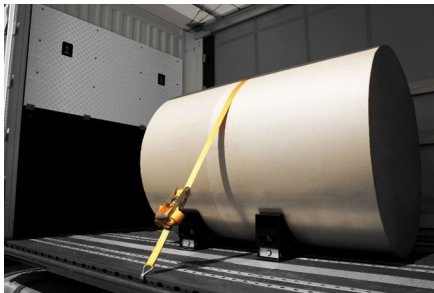

Paper transport



Paper transport floor

6.5. Intermodal Transport

Semi-trailers can be carried on a train. These types of trailers are equipped with 4 units of huckepack brackets, special axles and air suspensions. Trailer is lifted and loaded to train with a crane.



Train loading brackets

You can reach the information about which wagon types of your vehicle can be loaded on from the sticker located at front of side panel.





Train loading sticker

- (1) 5th wheel height that must be used at the wagon which trailer loaded.

- (2) Height of lowest level of vehicle when it connected suitable 5th wheel.
- (3) Suitable wagon types.
- (4) Load safety certification that vehicle has.

 **Be sure that the vehicle is loaded to suitable wagon type and height code.**

 **Fold upwards the foldable mudflaps before train loading.**

 **Foldable bumper must be lifted in order to load the vehicle to some A1 type etc. wagons. Be sure to check wagon requirements before train loading.**

 **Be sure that airbags are discharged completely and the vehicle is at the lowest level while loading the vehicle to train.**

 **After the train loading operation, make sure that the airbags are properly seated, the mudflap and bumper are brought to the driving position, and the vehicle is taken to the driving height**

6.6. Tyre Transportation

The features of the vehicles with our tyre transport certificate, which is one of our transportation solutions, are explained below:

- Having at least 2 rows of steel side rows and at least 5 rows of aluminum side rows, with a total of minimum 7 rows of side rows.
- Tightening straps for diagonal tightening
- Diagonal tightening strap apparatus

Arrangement of Side Row in Tyre Transportation

- For tyre transport, place a steel side row in the second and fourth rows from the bottom.
- To prevent excessive width, a diagonal strap tensoning system is applied with two tightening straps in the middle per pillar section. For this, the tightening strap apparatus is first attached to the steel side row.
- Insert the apparatus into the holes first and then attach it to the vertical position.
- Then slightly stretch the diagonal strap tensoning system with two tightening straps, with the pillar section in the middle.



Tyre transport

6.7. Customs Legislation

Your vehicle may have produced suitable to standards that stated in TIR legislation optionally.

There might be customs closure pieces to prevent the door from opening after the vehicle door is cleared. Also, some bolts are centered or closed with closure pieces due to customs legislation. Door handles have appropriate structure for customs seal.

TIR plates that located on the vehicle should be open through the operation and then should be closed afterwards.

Opening the plate: Open the closed plate sideways with switching the lock (1) 90° clockwise or counterclockwise, then fix the wing which opened with affixing to the lock (2) other side.

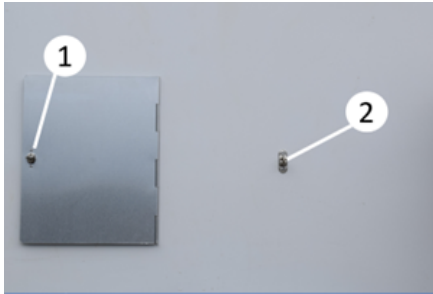

TIR plate opening



TIR plate

6.7.1. Semi-Trailer Structure in Accordance with Customs Legislation

In order for a semi-trailer to comply with the customs legislation;

- The parts that make up the semi-trailer (side board, front and rear panel, etc.) must be put together in such a way that they cannot be removed from the outside and replaced or replaced without leaving any open traces.
- Rear panels and other closing systems (boards, etc.) must have a device on which the customs seal can be applied. This device must not be removed without leaving a clear mark on the vehicle, and doors or

covers must not be opened without damaging the seal or assembly.

- Ventilation openings must contain a device to prevent entry or material from entering the vehicle, and the device must not be opened without leaving a clear trace from the outside.



Semi-trailer structure in accordance with customs legislation

6.7.2. Dangerous Goods Transportation (ADR)

Vehicles carrying dangerous goods should keep this plate in open position while driving. This plate is usually located at the rear of the vehicle, but its exact location may vary depending on the vehicle's construction. Approved vehicles in accordance with ADR legislation must have an ADR identification plate.

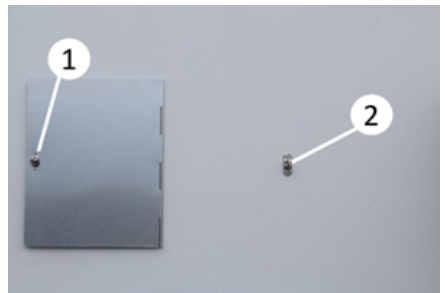

ADR plate opening



ADR plate locks

Opening the plate: Open the closed plate sideways with switching the lock

(1) 90° clockwise or counterclockwise, then fix the wing which opened with affixing to the lock (2) other side.



Dangerous materials that can be transported in the vehicle vary according to the vehicle structure and options. Make sure that the loads that comply with the regulations and your vehicle type are carried due to this.

7. LOADING AND LOAD SECURITY

7.1. Loading – Unloading Operations

Safety Reminder

- During the loading/unloading operations, the parking brake must be activated, and the vehicle must be fixed with Wheel chocks.
- To prevent slipping, tipping or sinking of the vehicle, the vehicle must be parked on a flat and firm surface.
- Ensure that you made a proper load distribution in compliance with all laws, rules and regulations.
- The suspension of the vehicle may be raised during the loading/ unloading process. Because of this reason, the vehicle height may be bigger than the permitted height limits. Always set the trailer in the driving position after loading and unloading. Always check height limits when entering tunnels and passages.
- Make sure that the weight or dimensions of the load do not exceed the technical and legal limits.
- Note that vehicle stability may be affected by the load distribution, the braking distance may be longer and a larger turning radius may be required.
- During loading, consider the laws of the countries you are going to and passing through, as well as the laws.
- Give attention to the maximum axle weight and total weight.
- Comply all national/international laws, rules, and regulations about loading and occupational safety.

7.2. Loading

- The load must be fixed properly. Otherwise, the load may be moved

during transportation or emergency brakes.

- Place the Cargo as close as possible to the loading area's floor. The center of the gravity of the load must always be on the center line of the vehicle.
- The load must be fixed with straps or load securing profiles. Be sure that the load is fixed safely.
- After the loading operations, be sure that all the components are suitable for the transportation.

7.3. Safety Instructions

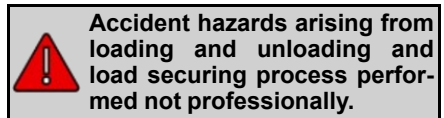

- Make sure that the cargo is properly distributed and in accordance with all laws, rules, and regulations. Check the loading limits, total weight, and axle load capacities. Do not exceed the weight limits which are defined in the user manual and identification plate. Comply with all national/international laws, rules and regulations about loading and occupational safety.
- Place the Cargo as close as possible to the loading area's floor. The center of gravity of the load must always be on the center line of the vehicle. Be all the regulations and laws about load security.
- While all vehicles are being designed, except for specific ones, it is assumed that the load will be distributed evenly on the load carriage surface and the calculations are done accordingly. Thus, the load up to the maximum carrying capacity of your vehicle must be distributed to ensure that equal weights are at the unit areas over the utilized carriage area. When the point loads are to be carried, a rigid distribution platform

must be placed under the load that will place the load up to the unit area capacity of the semi-trailer.

- While loading by crane or forklift, make sure that there is no one under and around the load.
- During the loading operation, do not exceed the permissible maximum height. A loading performed within the specified loading limit will ensure that you keep away from traffic accidents.
- It is dangerous and prohibited to fix the load to the vehicle surface via a tool apart from the permissible equipment.

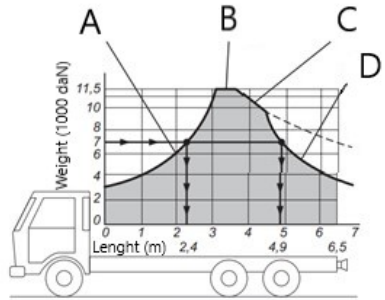

Load distribution

- A- Permissible front axle weight
- B- Permissible maximum weight
- C- Permissible rear axle weight
- D- Driving characteristic change limit

7.3.1. Load Security

The international Highways Regulations specify the maximum loading capacities of tractors, trucks, trailers, semi-trailers along with how and how much of the tonnage and dimensions of these loads are to be secured.

For instance, here, the distribution of the load amount that can be carried by a 6x2 truck per its axle, to the vehicle's weight center according to its horizontal and vertical distance.

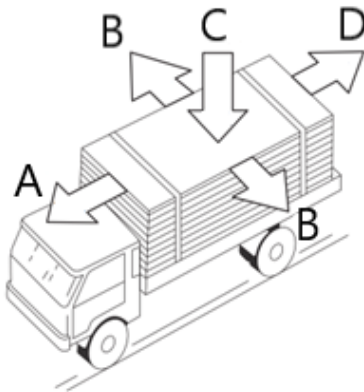

Forces may affect the vehicle

- A- Brake Force
- B- Centrifugal Force
- C- Static Weight Force
- D- Ramp / Hill Force

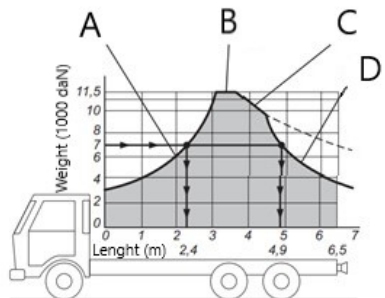

Load Distribution

- A- Permissible front axle weight
- B- Permissible maximum weight
- C- Permissible rear axle weight

D- Driving characteristic change limit

7.4. Load Distribution and Load Limits of Tractor Semi-trailer Combination

- Ensure that you made a proper load distribution in compliance with all laws, rules, and regulations.
- In the loading process, take the loading limits, total weight, and axle load capacities into the account.
- Ensure that you have performed the loading in compliance with the laws and regulations of all countries where you drive the vehicle.

The axle loads of the tractor/semi-trailer combination may vary in a broad range in relation to the various loading conditions. Comply with the permissible axle loads specified in the operation manual or the axle manufacturer's manual.

Whenever you are in doubt, have your loads checked at a proper weighing station.

***Axle load: This is the load conveyed by an axle or an axle group.**

7.5. K-Fix Side Rave

Side rave structure that allows connection from multiple points with the help of fasteners in order to carry the load safely.

- Each point on the K-Fix side rave, which is used to connect the load, has a tensile force of 2,000 kg.
- A load of 6,000 kg tensile force in total must be secured from 3 points along 1 m of the K-Fix side rave, provided that there is a distance of at least 225 mm between them.

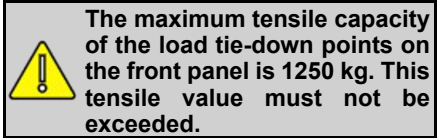
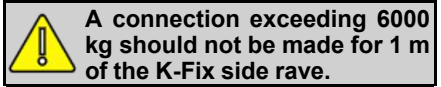
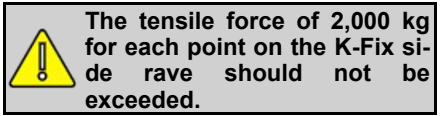

K-Fix

7.6. Lashing Rings

Your vehicle may be equipped with lashing rings which will allow fixing the cargo to the floor.

7.6.1. U Type Lashing Rings

These parts will be positioned on the side rave of chassis. You may fix the Cargo with U type lashing rings.

You may pull the rings and mount the straps.



U type lashing rings

7.6.2. Load Lashing Rings Placed on the Floor

Load lashing rings integrated into the base are used to fix the load to the floor.

You can put on your spanzet by pulling the lashing rings upwards with your hand.

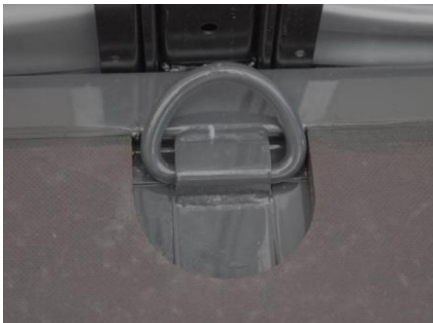

Load lashing rings placed on the floor

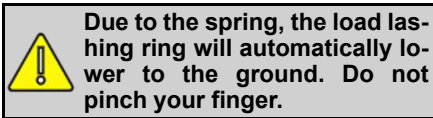

Due to the spring, the load lashing ring will automatically lower to the ground. Do not pinch your finger.

7.7. Lashing Rails

Lashing rails on the side Wall, roof and front panel may be provided optionally. These rails may be produced integrated or non-integrated types according to the vehicle construction.

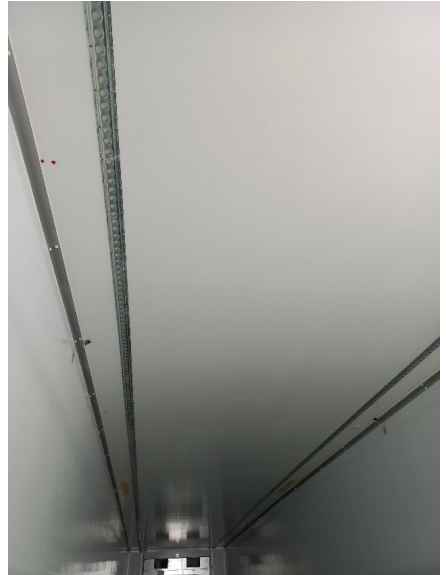

Lashing Rails

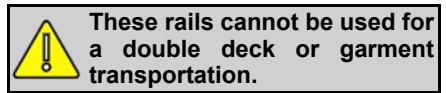

These rails cannot be used for a double deck or garment transportation.

7.8. Lashing Profiles

You may mount lashing profiles between the lashing rails and fix your cargo quickly. These profiles must be used only for fixing the cargo.

The transported cargo must be fixed from the front and the back side with these profiles without gaps between the cargo and profiles.

7.9. Ferry Rings

During ferry operations, ferry rings are used to fix the vehicle to the ship. A movable type ferry rings or fixed type (welded) ferry rings can be used in your vehicle. Both types are used for the same purpose.



Movable type Ferry rings

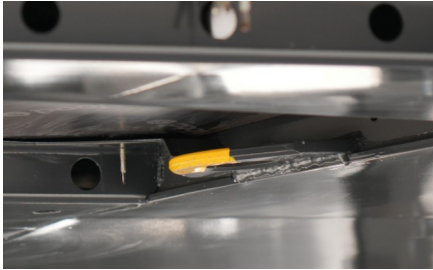

Fixed type Ferry rings



These rings must not be used to lift the vehicle.

The support parts must be put at the king pin area during the ferry transportation without a tractor. The area that supports parts will be positioned, is marked with stickers.

Your vehicle may be produced that is suitable for ferry operations. Please make ferry operations according to ISO 9367 norm.

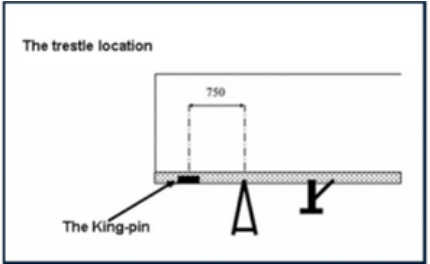

Support part and Ferry rings connections

7.10. Pallet Stopper

The pallet stopper prevents pallets or steel caged crates from slipping out of the loading area and is also used as a stop during the loading process.

Its carrying capacity is 2.000 daN.

Lashing with maximum loading is allowed in a maximum of three holes per meter.



Pallet Stopper

7.11. Telematic

Telematics, which allows you to monitor your vehicle remotely, is optionally available. Telematics should be used and maintained according to the manufacturer's manual. You can contact the manufacturer's authorized services for your warranty requests regarding these parts.



Telematic

7.12. Load Security Certification

The vehicle superstructure may have been produced in accordance with the DIN EN12642 legislation. This legislation indicates that in case of a possible accident if the load carried inside the vehicle hits the panels, no permanent damage will occur to the panels.



Load security certification sticker

For the maximum allowable panel strengths, you can check the load security label on the front panel.

Geprüfte Aufbaufestigkeit / Confirmed Bodystrength		
Vorderwand / Frontwall	0,5 P	xx.xxx kg
Seitenwand / Sidewall	0,4 P	xx.xxx kg
Seitenwand Doppelstock / Sidewall Doubledeck	0,5 P	xx.xxx kg
Rückwand / Rearwall	0,3 P	x.xxx kg
P = xx.xxx kg		
Fahrzeugaufbau entspricht	EN 12642-XL	
Vehicle body in compliance with		

Front Wall load securing sticker

8. INSPECTION AND MAINTENANCE

8.1. Safety Instructions

 There is a risk of accident that may arise in terms of a vehicle that is not built or built insufficiently. Read the following safety instructions carefully.

- Obey all traffic laws, rules and regulations.
- Comply with all environmental regulations. When removing operation, maintenance and cleaning residues, act according to these rules.
- Maintenance operations should be carried out by authorized services.

 If the EBS warning lamp comes on for any reason in the vehicle, immediately park the vehicle in the appropriate place and contact the nearest authorized service.

8.2. Main Principles

The purpose of the maintenance operations on the vehicle is to provide the following:

- Always maintain the operating status of the semi-trailer,
- To prevent unexpected breakdowns and to extend the life of the vehicle,
- To prevent permanent damage to the semi-trailer,
- To ensure that the semi-trailer maintains its value,
- Reducing repair time for unavoidable repairs,
- The vehicle should be regularly cleaned and kept clean.



After the ferry operation, when muddy or salty roads are used, when it is parked at the seaside for a long time, or when it meets a corrosive substance (salt, chemical liquids, etc.), the vehicle should be washed with plenty of water.

8.3. Checks to Be Performed Of The Time of the Delivery

- Check that the electrical system and connections and all lighting elements, brake and signal lamps are working properly.
- Check that the documents of the vehicle are in the vehicle.
- Grease the wheel plate and king pin.
- Check the tightness of the wheel nuts.
- Check that the landing gear works in both speed ranges.

8.4. Cataphoresis Coating

Your vehicle chassis or components may be cataphoresis coated.

Electro-coating (Cataphoresis) method is a coating method based on the accumulation of paint on the part with electric current. The most complicated parts and assemblies that require a high level of performance in terms of painting quality are covered.



If there is any damage on the cataphoresis coated areas, it should be repaired quickly by an Authorized Service.

8.5. Galvanized Coating

Your vehicle chassis or components may be galvanized.

White mottling on the hot-dip galvanized surface of new vehicles during the winter is normal and does not affect the quality

or life of the coating. Galvanized surfaces can be washed with water at a maximum temperature of 50 °C for the first 3 months.

8.6. Periodic Maintenance and Controls

For periodic maintenance and checks, see the warranty and maintenance manual.

8.7. Trouble Shooting

8.7.1. Safety Regulations

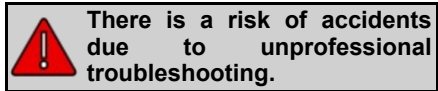

Read the following safety regulations.

- Comply with all laws, rules, and regulations to prevent accidents.
- Comply with all environmental protection rules. Dispose of process residues, cleaning aids and other residues in accordance with these rules.
- Troubleshooting work should only be carried out by trained personnel.
- Before troubleshooting, park the vehicle on a firm, and even surface and level it, and make sure that it is secured against sliding/tipping.
- Upon completion of the repair, ensure that all protective devices are correctly placed and secured.
- Only use original spare parts!

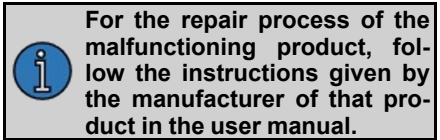
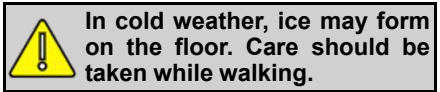

8.7.2. Spare Tire Replacement

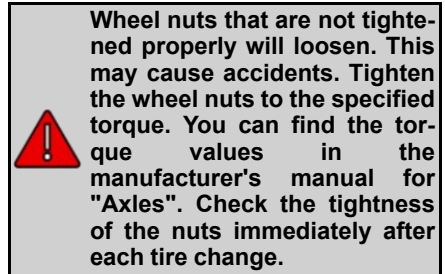

Removing the tire:

- Park the vehicle in a safe place away from traffic.
- Secure the vehicle with wheel chocks against rolling away or tipping over.
- Apply the springloaded parking brake. (See: "Construction Components and Use of Semi-trailer" for detailed information.)

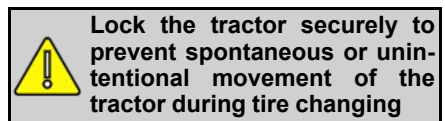

- Loosen the wheel nuts only one turn.
- Place the lever jack under the axle as close as possible to the tire to be replaced.
- Raise the axle until the tire to be replaced is no longer in contact with the ground. Remove the wheel nuts.



Take the damaged wheel off the axle, grab the wheel only by the right and left cheeks, never remove it by holding the top or bottom.

Remove the spare tire from its holder. See spare tire holder section for detailed information.

Fitting The Spare Tire:

- Position the spare tire as close to the wheel hub as possible.
- Lightly oil the nut threads when refitting the wheel.
- Insert a bar directly under the tire and push the wheel bolts into the holes of the rim by leveraging. Be careful not to damage the threads of the studs during this process.
- Tighten the wheel nuts as much as possible by hand tightening.
- Tighten the nuts with the wrench in the order shown in the picture.
- Lower the jack and tighten the wheel nuts in the same sequence with the required torque. Repeat this process after the first 80 km and daily for the first week.
- Check the wheel nuts for torque every week.



Possible problems that may arise in the future can be prevented by checking all the bolt holes on the rims against ovalization at regular intervals.

Excessive tightening of the nuts of the wheel bolts will cause radial deformations around the hole, and if not tightened enough, it will cause deformations around the hole.

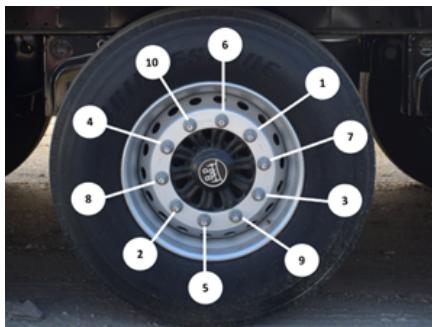

Bolt Holes In Rimes



Follow all maintenance instructions, including those of the manufacturer of the vehicle parts, and always keep these instructions in your vehicle.



The manufacturer cannot be held responsible for wear and defects caused by excessive force, or for malfunctions caused by unauthorized modifications. Irregularities or functional faults in the braking system must be rectified immediately! Only use vehicles whose brake system is functioning properly.



Kässbohrer Sales GmbH

Ulm | Im Katzenwinkel 5, 88480 Achstetten, Deutschland | T +49 (0) 7392 96797-0 | F +49 (0) 7392 96797-67

Goch | Siemensstraße 74, 47574 Deutschland | T +49 (0) 2823 9721-0 | F +49 (0) 2823 9721-21 | E info@kaessbohrer.com | www.kaessbohrer.com
info@kaessbohrer.com | spareparts@kaessbohrer.com | aftersales@kaessbohrer.com

Kässbohrer

Ingenuity, since 1893