



USER MANUAL

FUEL OIL TANKER SERIES



Index

1. GENERAL INFORMATION AND SAFETY INSTRUCTIONS	
1.1. About the User Manual	7
1.2. Meanings of Symbols Used in User Manual.....	7
1.3. Personal Protective Equipments.....	8
1.4. Terms of Use and Safety Information	9
1.5. Possible Dangers	9
1.6. Danger Areas.....	10
2. MAIN INFORMATIONS	
2.1. Vehicle Identification Plate	12
2.2. Brake Data Plate.....	12
2.3. VIN (Chassis) Numbers	12
2.4. Warranty and Responsibility	13
3. TRAILER RUNNING GEAR AND USAGE INSTRUCTIONS	
3.1. Brake System	14
3.1.1. Air Couplings.....	14
3.1.2. Compressed Air Tanks	16
3.1.3. EBS Socket.....	17
3.1.4. Roll Stability Support (RSS).....	18
3.1.5. PREV (Park Release Emergency Valve).....	19
3.1.6. Brake Chambers	20
3.2. Suspension System.....	21
3.2.1. Manuel Control Lever	21
3.2.2. Auto Reset.....	22
3.2.3. Electronic Controlled Air Suspension (ECAS).....	22
3.2.4. Smartboard (Info Center)	23
3.2.5. OptiTurn	23
3.3. Electrical System.....	24
3.3.1. 15 Pin Socket.....	24
3.3.2. 2x7 Pin Socket.....	25
3.3.3. Light System	26
3.4. King Pin	27
3.5. Landing Gear.....	27
3.5.1. Front Landing Gear's Working Principle.....	27
3.6. Side Protection Equipment (Underrun Protection)	29
3.7. Semi-Trailer Axle System.....	29
3.7.1. Axle Lifting.....	30

- 3.7.2. Hubodometer.....31
- 3.8. Tires.....31
 - 3.8.1. Tire Pressure Monitoring System (TPMS).....32
- 3.9. Spare Wheel Holder33
 - 3.9.1. Crane Type Spare Wheel Holder.....34
- 3.10. Mudguards.....34
- 3.11. Wheel Chock.....34
 - 3.11.1. Pin Type Wheel Chock Holder.....35
 - 3.11.2. Pocket Type Wheel Chock Holder35
- 3.12. Boxes and Storage Units35
 - 3.12.1. Aluminium Toolbox35
 - 3.12.2. Plastic Toolbox.....37
 - 3.12.3. Fire Extinguisher Cabinet37
 - 3.12.4. Water Tank38
 - 3.12.5. Document Box38
 - 3.12.6. Armature Box.....38
 - 3.12.7. Hose Carrier39
- 3.13. Working Lamp.....39
- 3.14. Grounding Pins.....39
- 3.15. Warning Signs40
- 3.16. Rear Bumper (Rear Protection Equipment)40
 - 3.16.1. Fixed Bumper.....40
 - 3.16.2. Reverse Audible Warning System.....40
 - 3.16.3. TailGUARD41
- 3.17. Handrail, Walkway and Ladder.....41
 - 3.17.1. Ladders.....41
 - 3.17.2. Foldable Ladder41
 - 3.17.3. Fixed Ladder42
 - 3.17.4. Left Handrail42
 - 3.17.5. Rope43

4. UPPERSTRUCTURE COMPONENTS AND USE

- 4.1. Overview to the Upperstructure Components on Tanker.....44
- 4.2. Filling and Discharging System45
 - 4.2.1. Manhole and Manhole Cover.....45
 - 4.2.2. Armature (Filling / Discharge) Box47
 - 4.2.3. Armature Box Cover48
 - 4.2.4. API Couplings and Dust Covers48
 - 4.2.5. Pneumatic Bottom Valves Control Block49
 - 4.2.6. Emergency Button Which Closes All Bottom Valves.....49

4.2.7.	Turning Product Presentation Apparatus	50
4.2.8.	'J' Type Channeled Over Filling Socket	50
4.2.9.	Gas Return Adapter, With Interlock System	50
4.2.10.	Park Brake Activation Valve	50
4.2.11.	Discharge Adapter	51
4.2.12.	'Ex-Proof' Lamp For Lighting Inside the Box and On-Off Power Switch	51
4.2.13.	Material Flow Observation Glass	52
4.2.14.	Air Conditioner	52
4.2.15.	Copper Hammer, Bucket and Shovel	52
4.2.16.	Emergency Button	53
4.2.17.	Measurement Systems	53
4.3.	Warning Labels On the Tank	53
4.4.	Product Plate Indicating the Transported Material	53
4.5.	Lifting Eye Bolt	53

5. TRANSPORTATION PROCESS

5.1.	Pre-Driving Checks	55
5.2.	Semi-Trailer and Tractor Coupling	55
5.3.	Cautions While Parking and Stopping	56
5.4.	Reversing Sensor	56
5.5.	Reversing Camera	57
5.6.	Important Technical Considerations	57
5.6.1.	Fire Extinguisher	57
5.6.2.	Wheel Chocks	58
5.6.3.	Modifications on the Trailer	58
5.6.4.	Air Leakage	58
5.6.5.	Considerations For the Environment	58
5.6.6.	Welding	59
5.7.	Cleaning of the Vehicle	59

6. TRANSPORTATION SOLUTIONS

6.1.	Fuel Tankers Sealing Points	62
6.2.	Dangerous Goods Transportation (ADR)	63

7. LOADING AND LOAD SAFETY

7.1.	Safety Instructions	64
7.1.1.	Load Safety	64
7.2.	Load Distribution and Load Limits of Tractor-Semi-trailer Combination	65
7.3.	Warnings Regarding Filling and Discharging	65

7.4.	Electronic Sealing System (SPD-Sealed Parcel Delivery).....	66
7.5.	Considerations During Loading – Unloading	66
7.6.	Filling	66
7.6.1.	Preparation of Filling	66
7.6.2.	Filling From Top	67
7.6.3.	Filling From Bottom	69
7.7.	Discharge.....	70
7.7.1.	Discharging With Pump	71
7.7.2.	Points to Check Before Starting the Pump.....	72
7.7.3.	Conditions for Getting the Most Benefit from the Pump and Using it in the Safest Way	73

8. INSPECTION AND MAINTENANCE

8.1.	Safety Instructions.....	75
8.2.	Main Principles	75
8.3.	Checks to Be Performed Of The Time of the Delivery	75
8.4.	Manhole Covers	75
8.5.	Periodic Maintenance and Controls	76
8.6.	Important Warning!	76
8.7.	Trouble Shooting.....	76
8.7.1.	Safety Instructions.....	76
8.7.2.	Spare Tire Replacement	77

FOREWORD

First of all, thank you for choosing us for your new vehicle investment.

Your vehicle is manufactured with the latest production technologies to the highest quality standards and equipped with the best safety and efficiency features.

You can find detailed information about the accessories, equipment and hardware that might be in your vehicle in this manual. The defined options in this manual can vary according to the vehicle specs.

Important information on how you can use your vehicle is explained in this user manual, please be sure that you review and understand the content. We suggest keeping this user manual available in your vehicle at all times. This information is specified in the product's user manual. We recommend you read this operating manual thoroughly to get the most out of your vehicle.

** Owing to the developments in product research, the manufacturer reserves the right to make any changes in the product, without any prior notice. The publication rights of this documentation belong to the manufacturer.*

1. GENERAL INFORMATION AND SAFETY INSTRUCTIONS

1.1. About the User Manual

The usage and operation information given in this manual is prepared to make sure the vehicle is used in compliance with its purpose and as desired.

The instructions here contain important recommendations to perform your operations safely, completely, and in the most efficient manner. Complying with these instructions, warnings and recommendations will prevent accidents, decrease down-time & repair costs, and make sure you use your vehicle safely, reliably and problem-free.

Please read the operating instructions in this manual carefully and completely. The manufacturer is not liable for the damages and deficiencies caused by the failure to comply with these instructions. The instructions herein must be supported by local laws, rules and regulations. Please comply with these instructions to prevent accidents and protect your surroundings and the environment.

Any usage of transportation that goes beyond the use in accordance with the rules will be considered improper use.

Transportation of the following is not allowed:

- Carrying people and live animals
- Transportations that need to be carried according to special instructions, e.g., dangerous good transportations
- Transportation of unsecured goods
- Transportation of materials that are dangerous due to their properties or that need to be carried with special equipment
- Exceeding technically and legally permissible weights of the axles or king pin load

- Exceeding of the maximum vehicle speed
- Exceeding the permissible length, width and height
- Unapproved parts like tires, accessories, spare parts and etc. by the manufacturer
- The manufacturer shall not accept any responsibility for the problems and faults that occurs that are not in compliance with the purpose of the vehicle's usage. All the risks of this issue belong to the customer.

 **It is necessary to keep the user manual available on the vehicle at all times.**

 **The vehicle can be equipped with a lot of different options. The standard or optional features will be explained in the manual. Some options may not be available for your vehicle**

 **Adhere strictly to the operating instructions when using your vehicle. When problems occur which can lead to dangerous consequences, contact the service centre immediately.**

1.2. Meanings of Symbols Used in User Manual

Several warnings are available in this manual to ensure maximum safety when using your vehicle. Each warning is indicated by a special symbol. These symbols and their meanings are as follows.



The information specified by this warning symbol is very important for health and human safety. When the given information is ignored, serious damage, injuries and even death may occur.



This symbol specified in this manual indicates that critical accidents may occur when the instructions do not comply.



This symbol is used when additional information is required.



This symbol is used when chemicals and other substances can be disposed of with precautions that will not harm the environment.

1.3. Personal Protective Equipments

Personal protective equipments serves the purpose of preventing injuries and are prevents injuries and are determined by regional regulations depending on the load carried.

People who will work or perform operations on the vehicle must wear proper and appropriate protective clothing.

- Depending on the load to be carried, the eyes, ears, body, and respiratory tract must be protected with the relevant protective equipment.
- As a rule, gloves and work shoes are always used.



It is obligatory to use appropriate personal protective equipment during the operations.



Long hair is particularly dangerous when working on the vehicle, regardless of whether it is loose or tied up, and it should be protected properly to avoid tangling.



Wearing a tie, necklace and/or dangling jewelry when working on the vehicle is strictly prohibited. They may get caught in moving parts or mechanisms and cause injuries and even death.

Protective Gloves



During the operation, protective gloves must be used. Please make sure you are using the correct type of gloves when you are working with hot parts or chemicals.



Gloves should fit snugly. Otherwise, there is a risk of them getting caught in moving parts or mechanisms.

Protective Cloth



While working on the vehicle, appropriate overalls must be worn.

- Overalls should not have pleats, buttons or external pockets and their closure system should be made in such a way that they can be opened as soon as possible in case of an emergency.
- Interior pockets should have fastenings to close them up. Cuffs should be adjusted to fit the wrist.

Protective Helmets



When working around the vehicle, a lightweight helmet approved by an accredited institution should be worn.

Protective Ear Plugs



A hearing protective device (headsets or ear plugs) should always be used around self-propelled vehicles.

Protective Goggles



Protective goggles should be worn during all maintenance operations.

Protective Mask



Appropriate protective masks should be used when working with substances that are dangerous to breathe or in dusty environments.

1.4. Terms of Use and Safety Information

It is necessary to keep the warranty, operating and maintenance manual and other documentation about the vehicle available on the vehicle at all times.

1.5. Possible Dangers

Your tanker vehicle has been designed using the most up-to-date technology and in compliance with generally accepted technical safety regulations and rules. Nevertheless, its use could involve risk of injury and death to the user and to others and damage to the vehicle itself and to other objects.

Below is a summary of dangers that can occur while working with the tanker vehicle. It is recommended to read these dangers entirely.

Danger Source	Consequences
Contact with the load when unloading, loading or cleaning	<p>Risk of injury of poisoning!</p> <p>Breathing load or contact with skin or eyes may result in injury.</p> <ul style="list-style-type: none"> • Avoid physical contact with load and avoid breathing vapour resulted from load.

To prevent possible accidents and environmental pollution, follow the operating instructions and binding regulations.

- Pay attention to the safety and warning signs placed on your vehicle.
- Always keep these safety and warning signs completely visible.
- Make sure that the load carrier is secured properly.
- In case of any dangerous condition in the operation of safety, stop your vehicle immediately and inform the authorized people or institutions.
- Do not modify anything on the vehicle without a written manufacturer's approval. Your vehicles guarantee terms do not cover unapproved modifications.
- The spare parts must meet the technical requirements set forth by the manufacturer company. Only the original spare part/parts meet their requirements.

	<ul style="list-style-type: none"> • Never loosen connection hoses during loading or unloading. • Wear protective clothes against load and hazards that may arise from load. • If the load causes an injury, contact to material safety document for necessary emergency measures.
Rubbing of load against tank walls and connections	<p>Risk of fire and explosion!</p> <p>If the identical potential conductor (grounding pins) is not connected, static load may cause sparks and explosions.</p> <ul style="list-style-type: none"> • Connect grounding pins during loading, unloading and cleaning.
Entering into the tank	<p>Risk of fatal injury!</p> <p>Entering into the tank after the journey for cleaning, inspection and maintenance purposes will lead to serious health risks.</p> <ul style="list-style-type: none"> • Do not enter into the tank when not necessary. • Conduct the necessary gas measurements appropriately before entering into the tank.

1.6. Danger Areas

In this section, dangerous areas on and around the tanker vehicle and dangers that may occur are briefly described.

Danger Area	Action to be performed
Between the tractor and tanker vehicle	<p>Risk of sticking persons during fastening or unfastening tractor and tanker vehicle.</p> <ul style="list-style-type: none"> • People should be far off from the danger area.
Around tanker vehicle and filling – discharging area	<p>In accordance with ADR legislation, no action should be taken in zone 0, zone 1 and the area within half a meter diameter of the gas adapter, which may cause sparks, and should not be approached with elements that may cause fire or flashing.</p>

<p>Around tanker vehicle</p>	<p>Presenting unauthorized persons around the vehicle during loading and unloading is dangerous for you and other persons.</p> <ul style="list-style-type: none"> • Ensure the unauthorized persons are outside the danger area.
<p>Tanker body</p>	<p>It is obligatory to perform gas-free operation on the tanker body before any operations that may create a spark or explosion risk (welding, etc.) on the tanker body.</p>
<p>All sides of not connected tanker vehicle</p>	<p>In some cases not connected tanker can suddenly fall down and injure people.</p> <ul style="list-style-type: none"> • For this reason never stay around the tanker not connected to tractor. • Tanker should be in safe condition for maintenance operations.

2. MAIN INFORMATIONS

There are vehicle identification stickers on the vehicle.

2.1. Vehicle Identification Plate

Vehicle identification plate is located on the right side of the vehicle.

You may find the following information's on this plate;



Vehicle identification plate

- 1- Type approval number
- 2- VIN number
- 3- Technical total capacity
- 4- Technical king pin capacity
- 5- Technical an axle capacity
- 6- Technical total axle capacity
- 7- Nationally approved total capacity
- 8- Nationally approved king pin capacity
- 9- Nationally approved an axle capacity
- 10- Nationally approved total axle capacity
- 11- Vehicle Type

In addition, since fuel tankers are non-pressurized vessels carrying dangerous goods, this plate conforms to ADR and has the seal of approval by the 3rd organization. Tested gross volumes appear on this plate.

2.2. Brake Data Plate

There is a brake data plate (2) on the vehicle which is equipped with an EBS system.

You may see this information on this plate.

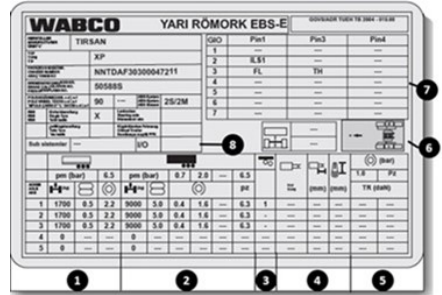

EBS Plate

1	Empty vehicle (without load)
2	Loaded vehicle
3	Axle lifting
4	Brake chamber data's
5	References
6	Driving height
7	Pin positions
8	IN/OUT-Connections

2.3. VIN (Chassis) Numbers

The VIN (chassis) number is located on the right side of the vehicle and marked with a different color than the chassis color.



- 1- VIN Number
- 2- Chassis plate
- 3- ADR plate
- 4- Brake plate

2.4. Warranty and Responsibility

Our trailers, semi-trailers and truck on-board applications are manufactured in compliance with regulations and our quality standards. It is necessary to perform the maintenance to ensure our products always operate in the most efficient manner in compliance with our latest directives and maintenance programs. The warranty starting date is the date that the vehicle is delivered to the customer.

The performance of maintenance and repair/servicing of the vehicle with the use of original spare parts by authorized service shall assure the client's warranty rights. This warranty is based upon the usage and maintenance conditions described herein and in the warranty book. Thus, it is important to read and understand this operation manual and warranty book.

It is necessary to keep the warranty, always operating and maintenance manual available on the vehicle to allow authorized service performing the servicing to see the warranty conditions and maintenance records. In the repairs made during the warranty period, the authorized service performing the repair will demand this. Purchasing one trailer or semi-trailer is an important investment. For the highest return on your investment, it is necessary to comply with the manufacturer's procedures and recommendations during the operation period of the vehicle. The information provided by the client/driver related to the warranty written in this manual shall be kept within our database.

3. TRAILER RUNNING GEAR AND USAGE INSTRUCTIONS

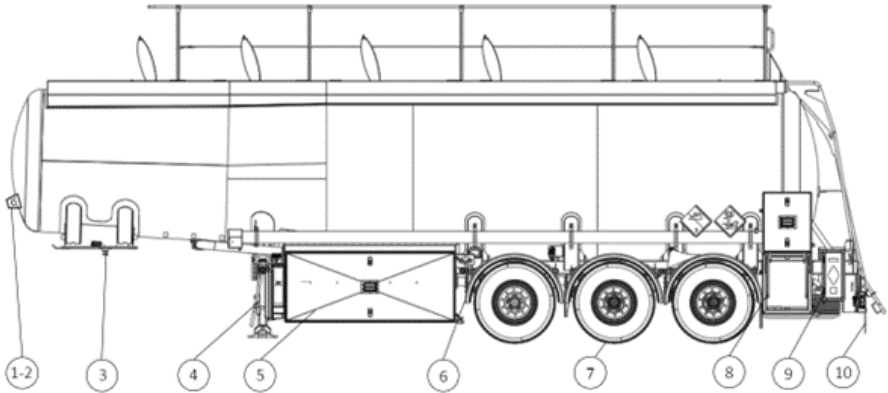

1-2 Brake/Electric Connections

3 King Pin

4 Landing Legs

5 Armature Box

6 Mudguards

7 Tires

8 Toolbox

9 Fire Extinguisher Box

10 Bumper

Supply Line: Pneumatically air hose which will feeds the air tanks and trailer.

According to the type of vehicle, your vehicle can be equipped with one or two different types of air couplings.

- Standard Couplings (Palm)
- Duomatic Coupling
- C (UK) Couplings

3.1. Brake System

3.1.1. Air Couplings

The main connection between the truck and trailers is air couplings.

Generally, 3 different types of air couplings are used in the trailers. These 3 types of air couplings have the same function but with different shapes and connections. There are 2 different air supply lines in the system.

- Brake Line (Yellow)
- Supply Line (Red)

Service Line: Pneumatically air hose which will feeds the brake line.



If your vehicle is equipped with 2 different types of couplings, you must use only one type at the same time.



When the couplings are mounting/demounting, the parking brake of the truck and trailer must be engaged.



If the brake parameters are modified, your vehicle's brake calculation might be non-suitable for regulations. Only authorized services must service to the EBS modulator.



Only authorized services and personnel should make service operations for the brake system.

There might be test points on the chassis or above the air couplings. When you remove the test points rubber protection parts and push the points you can check the air pressure on the brake lines.



Test point



Palm coupling with a test point

3.1.1.1. Mounting of Standard (Palm) Couplings



Couplings

- Slightly slide plastic covers to the upper side. Slide plastic covers to upper side.
- Be sure that sealing surfaces are clean and durable. If necessary, clean/change the air coupling.
- The coupling which comes from the truck should be pushed slightly from the upper side to the lower side and connect the coupling. Be sure that couplings are matched correctly.
- First mount service line yellow (1).
- Mount supply line red (2).

3.1.1.2. Demounting of Standard (Palm) Couplings

- The coupling which comes from the truck should be pushed slightly from the lower side to the upper side and demount the coupling.
- First demount the supply line red (2).
- Demount the service line yellow (1).
- Slightly slide plastic covers to the lower side and close the plastic covers.

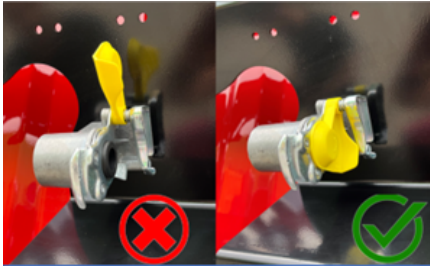

Closing the coupling

 **Driving with a non-suitable air connection is dangerous and forbidden.**

 **Using damaged air supply parts can cause serious hazards. Torn or damaged compressed air connectors reduce the vehicle's braking performance.**

3.1.1.3. Mounting of C (UK) Couplings

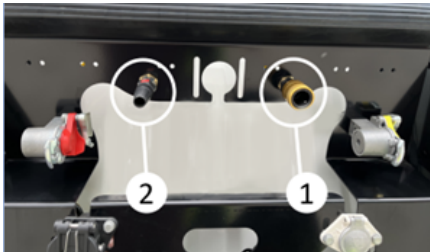

Mounting the C (UK) Couplings

- Be sure that sealing surfaces are clean and durable. If necessary, clean/change the air coupling.
- First mount service line yellow (1).
- Mount supply line red (2).
- Be sure that couplings are matched correctly.

3.1.1.4. Demounting of C (UK) Couplings

- Push the latch from front to back side on the C couplings and remove.

- First demount the supply line red (2).
- Demount the service line yellow (1).

 **The coupling filters have to be clean regularly.**

3.1.1.5. Mounting of Duomatic Coupling



Duomatic Coupling Connection

- Be sure that sealing surfaces are clean and durable. If necessary, clean/change the air coupling.
- Push the arm and mount the coupling (1).

 **The coupling filters must be clean regularly.**

3.1.1.6. Demounting of Duomatic Coupling

- Push the arm and mount the coupling (1).
- Pull back the arm slightly and close the coupling cover.

3.1.2. Compressed Air Tanks

Pressured air can be stored in the air tanks.

The quantities and capacities of the air tanks can be changed according to your vehicle specifications.

In cold periods of the year or when the air humidity is high, the moisture in the

air can be condensed and collected in the compressed air tank.

The tractors are generally fitted with air driers to prevent condensation in compressed air. The tractors are generally fitted with air driers to prevent condensation in compressed air. Even if the air driers system, the humidity in the air can be condensed. The condensed water must be drained out via the drain valve.

The water in the air tanks should be completely drained out. That's why please push the valve on the air tanks.

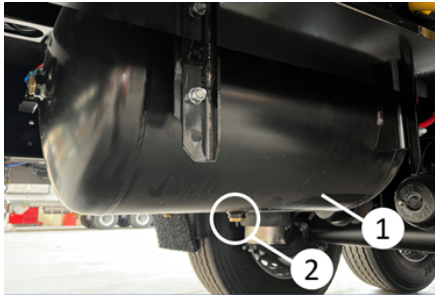

- 1. Compressed Air Tanks
- 2. Drain valve

 The water in the compressed air tank can cause corrosion problems and affect the functionality of the brake system. The frozen water in the pneumatic lines can cause the failure of the brake system.

 The water in the pneumatic system should be checked more frequently in cold weather or extremely variable outside temperatures.

 When the air tank pressure is lower than 4,5 bars, the EBS warning lamp on the tractor turns on and the driver can see this situation.

 When the pressure in the service line (in the red coupling) is lower than 2,5 bars, the brakes automatically lock.

3.1.3. EBS Socket



EBS Socket



EBS Socket

Our trailers and semi-trailers are equipped with an EBS system.

EBS is an electronically controlled brake system, that is fitted with automatic load sensing braking pressure regulation (ALB) and automatic anti-skid systems (ABS/ABV).

To activate the EBS system, your truck and trailer must be equipped with an EBS system. Please mount the EBS cable that will come from the truck to the EBS socket on the trailer.

- Driving with a non-connected EBS connection is illegal.
- Drive only with an approved and well-operating EBS plug connection in accordance with regulations.
- EBS connection must be made between the truck and trailer.
- When the EBS socket mounted and truck engine is activated, you will hear the noise. Please listen and check carefully.
- A system control is performed two seconds after the trailer EBS is switched on; in the meantime, the magnets may be opened and closed audibly for a short time. When plugging the EBS connector, if you cannot hear the system control, a power supply problem exists between the tractor and EBS.

When the truck engine is activated and during the travel, the EBS system will be checked automatically. If the truck screen is suitable/adjusted, the EBS failures will be shown with the EBS mistake lamp.

The EBS mistake lamp on the truck screen will be turned on when the ignition key is activated. If there is no failure on the EBS system, the lamp will be turned off in appr. 2 seconds.

After 7 km/hours speed, if there is a failure on the EBS system (Sensor mistake and etc.) EBS lamps will be flashed.

If the EBS lamp is activated, please contact with authorized services immediately.

 **The trailers equipped with a Trailer EBS E braking system may only be used with tractors with:**

- ISO 7638-1996 connectors (ABS + CAN) or ISO 7638, 7 pin with CAN data line (EBS Truck)

 **If you drive without EBS connectors or if there is a problem on the EBS system, the brake system will not be worked properly. This situation may cause an accident.**

 **Trailers are equipped with an additional power supply for the EBS system. Thanks to the extra power supply from brake lamps, when the EBS connector is damaged, an extra safety function will be activated. The EBS system will be fed from brake lamps and ALB (automatic load sensing braking pressure) and ABV (anti-skid system) functions will be activated.**

3.1.4. Roll Stability Support (RSS)

Rollover stability support (RSS) is integrated into the trailer modulator. But

don't forget that this system cannot cancel the laws of physics. The vehicle's electronic control unit analyzes wheel speed, load information and transverse acceleration data to detect the likelihood of vehicle roll-over before the driver realizes there is a risk and automatically applies the brakes. But don't forget that this system cannot cancel the laws of physics.

When the roll-over risk is detected, the EBS system makes automatically brakes and tries the reduce the roll-over risk. After risk, the RSS function will be shut down automatically.

 **The RSS optimizes driving characteristics and in emergencies may help to prevent accidents. But cannot completely guarantee.**

3.1.5. PREV (Park Release Emergency Valve)

Generally, brake control systems will be located on the driver's side. It may be different on your vehicle according to the vehicle's construction.



PREV Buttons

Black button (1): Service brake button.

Red button (2): Park brake button

 **When you are driving the trailers, the red button must be pushed position and the black button has to be pulled position.**

3.1.5.1. Service Brake

Thanks to the service brake, the trailer can be made maneuvers without air connections. The black button can be used only without air connections on the trailer.

When you push the black button, the service brake will be disabled. When you pull the black button, the service brake will be activated.

 **If the service brake is used a lot of times, without an air connection, air pressure in the system and braking power may reduce.**

When the air connections are de-mounted, the service brake will be automatically activated. When the air connections are mounted, the service brake will be automatically disabled.



The service brake is not suitable for braking of the semi-trailer permanently. During longer waiting periods, the semi-trailer must be secured with a spring-loaded park brake and with wheel chocks.

3.1.5.2. Spring Loaded Park Brake



Spring loaded park brake

Spring loaded park brake control button is used for longer parks of semi-trailers with or without tractor on plain or inclined lands.

When the red button is pulled, spring loaded park brake will be activated. When the operator pushes the red button, spring loaded park brake is deactivated.



This brake will not be deactivated automatically. Before driving, the operator must deactivate the brake.

3.1.6. Brake Chambers

Your vehicle may be equipped with disc or drum brake axles according to your choice. For both brake types, the brake chambers are going to use for braking. The brake chambers will be chosen according to axles type and loading capacity. The maintenance, modification or repair operations must be performed by authorized services.

3.1.6.1. Manually Deactivation of Parking Brake Spring

The Parking brake spring may be deactivated manually in emergency situations.

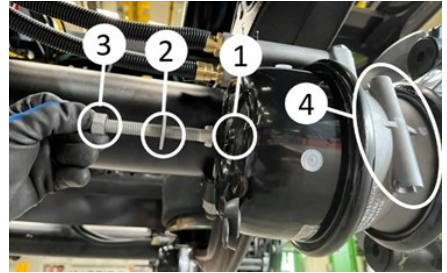

Deactivation of brake chambers

1. Boreholes
2. Release rod
3. Nut
4. Slot of the release rod

- Remove the release rod (2) from the slot (4).
- Insert the release rod (2) to boreholes (1) and screw till the rod (2) will be fitted completely.
- Completely screw in the nut (3) to the release rod (2).

The brake chambers will be deactivated after this operation. In this case, the brake chamber only works on the service brakes. Even if the trailer air tube pressure drops below 2.5 Bar, the spring brake will not be activated due to this operation.

On some brake chambers used in vehicles, the emergency release screw is located in its socket (1) behind the brake chamber, not in its socket (4) next to it. In order to disable the springs, it is allowed to come out by simply turning it with the appropriate key.



This operation should only be used until the trailer is serviced.



Before this operation, the vehicle must be fixed securely with wheel chocks. Serious injuries may occur.

3.1.6.2. Activation of Brake Chambers

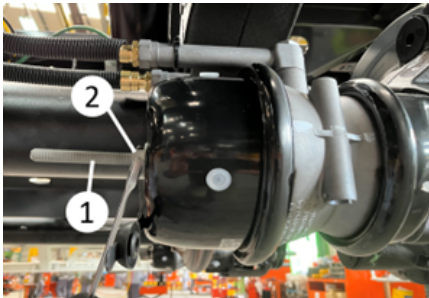

Activation of brake chambers

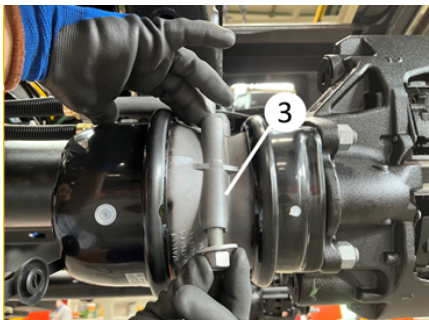

- Remove the nut (1) from release rod (2) with a spanner.
- Remove the release rod (2).
- Screw the release rod into its place on the brake chambers (3)

- Close the plastic cover on the brake chamber.

Brake chamber will be activated after this operation.



Before this operation, the vehicle must be fixed securely with wheel chocks. Serious injuries may occur.



Don't drive without being sure that all the brake system is working properly after this operation

3.2. Suspension System

Your vehicle is equipped with air suspension system.



When entering uneven or damaged roads, the fifth-wheel plate height and the trailer should be raised. Otherwise, the front part of the trailer may come into contact with the tractor, or trailer components may be damaged. While raising the vehicle, check the external height and make sure it does not hit anything. Comply with legal height limits. Once the problematic area has been passed, the vehicle should be returned to driving height.

3.2.1. Manuel Control Lever

Operation;

In the driving position, the air suspension system keeps the semi-trailer permanently at a certain level independently from the load. The lowering/raising lever (1) at the control panel can lower or raise the semi-trailer. for ramp adjustment on the loaded position.

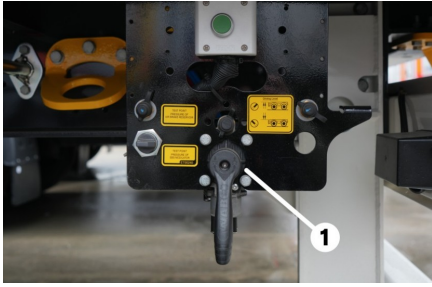

Driving position of lever

You may turn the lever according to anti-clockwise and raise the trailer.

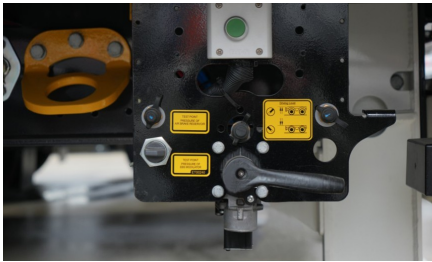

Raising of suspension

You may turn the lever according to clockwise and lower the trailer.

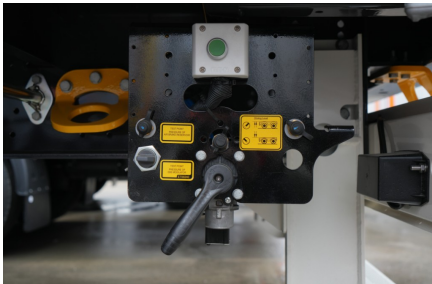

Lowering of suspension

To fix the suspension height, you may turn the lever 45° or 135° according to the photo in below. Before driving, the lever must be switched to driving position.



Fixing of suspension height

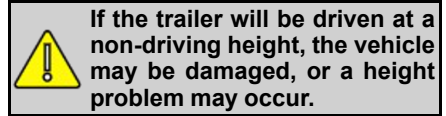

If the trailer will be driven at a non-driving height, the vehicle may be damaged, or a height problem may occur.

3.2.2. Auto Reset

The auto reset lever can be controlled by the same method as 3.2.1. manual suspension control lever. When the EBS socket is mounted and driving at a speed defined by the producer, the lever will set the driving height automatically.



Auto reset

3.2.3. Electronic Controlled Air Suspension (ECAS)

Electronic controller air suspension (ECAS) is an optional solution. This system sets the driving height or defined different heights electronically. When the EBS socket is mounted and driving at a speed defined by the producer, the lever will set the driving height automatically.

You may push the lower or raise button and set the vehicle height.



ECAS control panel

3.2.4. Smartboard (Info Center)

Thanks to Smartboard, the operator may see failure codes, axle load etc. information and control the axle lifting system.

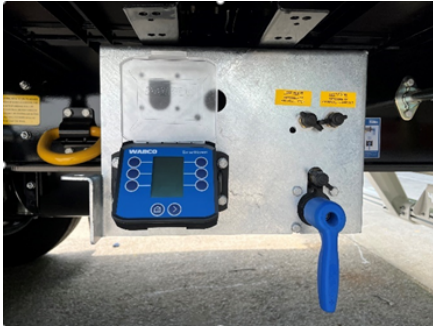

Smartboard

If your Smartboard includes the battery, you may use some control even if the truck is not connected.



You may check Smartboard user Manual for the detail information.

3.2.5. OptiTurn

The Smart OptiTurn™ function increases the trailer's turning radius by up to 0.5 meters and improves the driver's ability to handle short ramps. It facilitates maneuvering in loading bays and city

centers. This innovative function automatically detects corners and curves, releasing the pressure of the rear axle airbag or lifting the rear axle during maneuvering. This provides additional steering support.

Benefits

- It extends tire life.
- It enables safer maneuvering in crowded city streets and small intersections.
- It improves maneuverability in small areas.
- It improves turning capability while reversing.
- The trailer can be upgraded with EBS-E version 1 or newer.

Features

It enables the trailer to follow the vehicle's driving path more accurately in curves and intersections.

It automatically detects when the vehicle enters a curve and lifts the third trailer axle.

It increases the turning speed by up to 0.5 meters by lifting the axle and shortening the wheelbase.

It automatically takes into account the total permitted weight per axle.

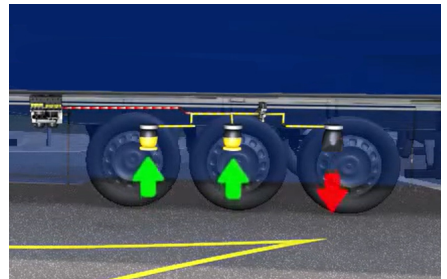

OptiTurn

3.3. Electrical System

There is 15 pin (1) electrical socket in our vehicles. Thanks to this socket, electrical connections between truck and trailer will be made.

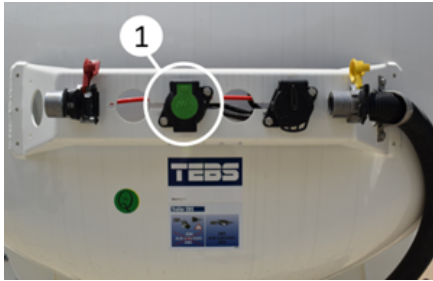

15 pin socket

 **When driving, the electrical sockets between the truck and trailer must be connected.**

 **Please be sure that the truck and trailer are suitable for the norms/standard about electrical systems. Otherwise, electrical problems will occur.**

3.3.1. 15 Pin Socket

This system provides electricity for the electrical system on the vehicle like stop lamps, signal lamps etc. 15 pin socket connections are made according to ISO 12098.

Open the protection cover and mount the sockets regularly.

You may find extra information about the pins function in below.



Pin	Meaning
1	Left indicator
2	Right indicator
3	Fog lamp
4	Ground
5	Left taillight
6	Right taillight
7	Brake light
8	Reverse light
9	Supply line
10	Brake Lining Wear
11	Traction help/Force Lowering

12	Axle Lift
13	Chassis Electronics
14	Empty
15	Empty

5	Empty
6	Axle Lift
7	Fog lamps

3.3.2. 2x7 Pin Socket

This system provides electricity for the electrical system on the vehicle like stop lamps, signal lamps etc. 2x7 pin socket pin connections are made suitable for 24S ISO 3731 and 24N ISO 1185 norm.

Open the protection cover and mount the sockets regularly.

You may find extra information about the pins function in below.

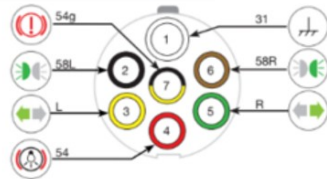

ISO 1185 Soket



ISO3731 Soket

Pin	Meaning
1	Ground
2	Left taillight
3	Left indicator
4	Brake light
5	Right indicator
6	Right taillight
7	EBS

Pin	Meaning
1	Ground
2	Empty
3	Reversing lamp
4	Supply line



Please be careful with the color of the sockets. The black socket is suitable for ISO 1185 and the white socket is suitable for ISO 3731. If the vehicles are suitable for norms, the

black socket on the truck will be connected to the black socket on the trailer and the white socket on the truck will be connected to the white socket on the trailer.

3.3.3. Light System

The vehicle is equipped with a light system which is suitable for the regulations.

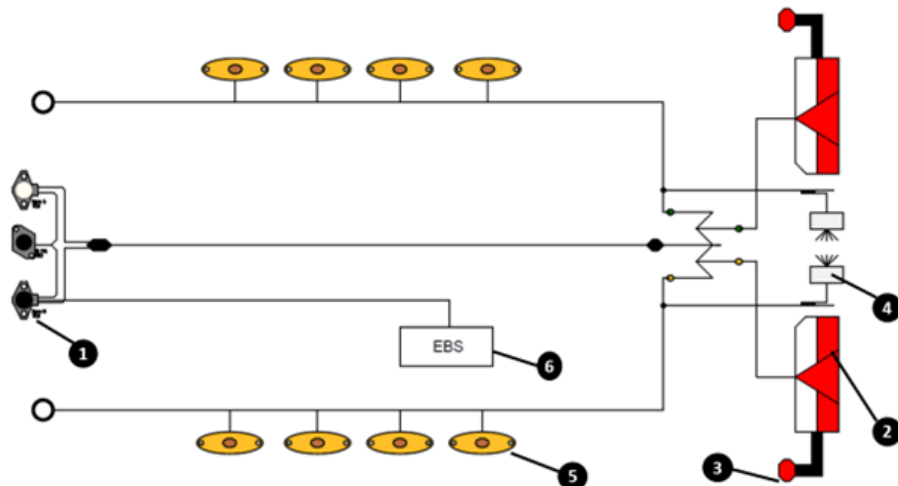

1	Electrical Sockets
2	Stop Lamps
3	End Outline Markers
4	License Plate Lamps
5	Side Position Lamp
6	Modulator

The lamps must be checked regularly. If there is any problem with the electrical system, it must be repaired immediately. In a repair operations, only original and approved sockets or parts must be used.



If you add or remove any lamps on the vehicle, your vehicle may be non-suitable for regulations.



Vehicles with LED electrical systems consume very low energy. For this reason, although there is no problem in the system, it may cause the failure lamp to come on in old tractors.



Repairing operations of the electrical system have to be made by only authorized services. Otherwise, electrical problems may occur or your vehicle may be out of warranty.

3.4. King Pin

King pin is a shaft which connects truck and railer together. Your vehicle may be equipped with 2" or 3.5" diameter pins. Please check the king pin diameter before connecting the truck.

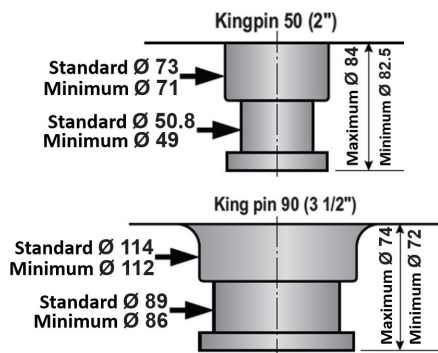

If you match the truck and trailer with a different diameter king pin, injuries may occur.

The flanged king pin is used on the vehicle. That's why king pin can be replaced easily.



Kingpin



If the wearing on the king pin is bigger than 2 mm, the king pin must be replaced.

Your vehicle may be equipped with a double king pin slot. You can remove the bolts around the king pin and mount king pin to the other slot. Please be careful about the total length of the vehicle according to country regulations and be sure that the total length is suitable for regulations.

3.5. Landing Gear

There is a front landing gears behind the vehicle's gooseneck area so that your vehicle can stop in park without truck.

3.5.1. Front Landing Gear's Working Principle

The landing gear crank handle (1) should be removed from its holder (2) and brought to a perpendicular position to the vehicle.

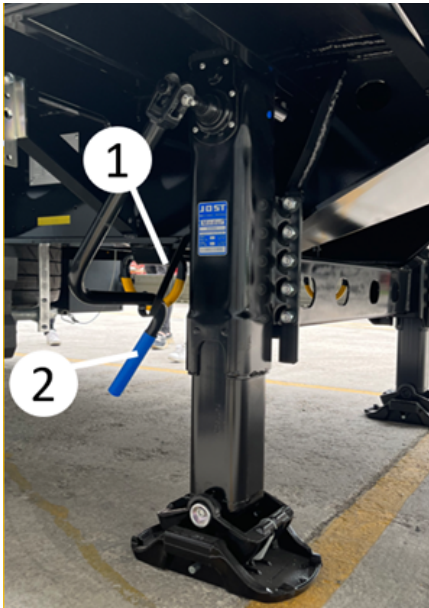

Landing Gear

Low Speed (A): When the crank handle (1) is turned in the fully pressed position, it raises / lowers at low speed.

High Speed (B): It performs high speed lifting / lowering when the lever turned in the fully extended position. The position is used to quickly lower the gear until the foot (plates) touch the ground during the process of separating the semi-trailer from the tractor, or to raise the gear quickly after the semi-trailer is connected to the tractor.



The landing gear crank handle is usually located on the passenger side of the vehicle.

 In all conditions, secure the semi-trailer against tipping with correctly positioned wheel wedges. If the vehicle is not properly secured, the landing gear or the vehicle may be damaged.

 If the loading / unloading operation is performed while semi-trailer is not paired with the tractor, the front or rear of the vehicle may raise. Serious accident and damaged may occur. For this reason, the semi-trailer must be paired with the tractor during the loading and unloading operations.

 If the tractor leaves from the loaded trailer, be sure that the load is distributed homogeneously in the vehicle. Otherwise, the front or rear section of the vehicle may be raised due to centre of gravity, and accident may occur.

In order to protect the landing gear, be sure that there won't be any lateral movements on your vehicle. For this reason give attention to the following criteria:

- Disconnect the semi-trailer from the tractor only when the landing gear are in the middle (neutral) position.
- If you will park for a long time without the coupled tractor, be sure that air suspensions are lowered and after that adjust the landing gears. Thus, the loading area will be parallel to the ground.



Landing gear view

Optionally, an aluminum landing gear can be supplied.

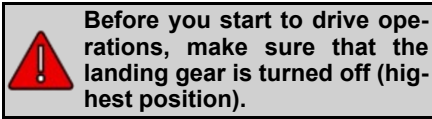

Before you start to drive operations, make sure that the landing gear is turned off (highest position).

3.6. Side Protection Equipment (Underrun Protection)

The side protection equipment must be in the off position while driving. Some side protection equipment can be opened upwards to facilitate service operations such as accessing the spare tire.



Underrun protection

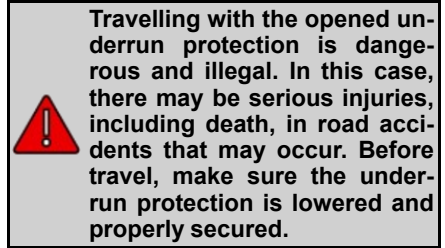

Travelling with the opened underrun protection is dangerous and illegal. In this case, there may be serious injuries, including death, in road accidents that may occur. Before travel, make sure the underrun protection is lowered and properly secured.

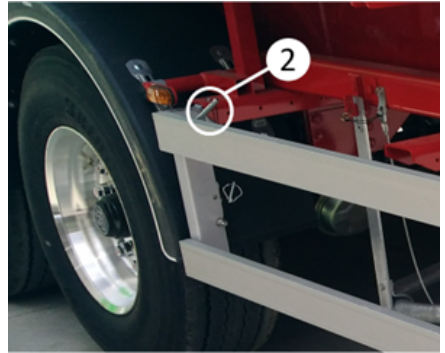

Pin

Removing Underrun Protection: After opening the protection release pins (2) on both sides, the underrun protection is removed and taken out.



If the underrun protection is not fixed properly, it may fall and cause injury.

Installing Underrun Protection: Insert the protection into its slot from both sides and insert the pins.

3.7. Semi-Trailer Axle System

Axle with disc or drum type brake mechanism are used in your vehicles.

Semi-trailer axles may only be loaded with the maximum legally permissible axle load indicated on the vehicle identification plate. The user is responsible for use of the trailer in accordance with its purpose and capacity and for its maintenance.

The healthy operation of the brake system of the semi-trailer depends on the usage of the semi-trailer with the same system and/or compatible tractor. For

this reason, it is obligatory for the buyer to make the brake adjustment at the authorized service of the tractor company to which these semi-trailer/trailers are to be matched. If you use the unadjusted truck-trailer combination, the producer doesn't take any responsibility for the damage/failure that may occur in the brake system or vehicles. All responsibility belongs to the customer.



For more information about the axles, please check the axle's user manual which was delivered with your vehicle.



If the axles are used other than the conditions specified in the manufacturer's manual or if their maintenance is not made properly, your vehicle may be out of warranty.



If the vehicle is equipped with emergency brake chambers, apply the parking brake after checking the drum temperature. Never use the parking brake when the drums are very hot (the drum may crack).

3.7.1. Axle Lifting

Axle lifting feature is optionally available in different quantities and location in your vehicle. Thanks to this feature tire wear is minimized and a more balanced load distribution on the tractor can be achieved. The EBS connection must be active for the axle lift load to work.

Axle lifting feature is controlled automatically due to the legal regulations. When the speed limit exceeded while the EBS is active, some axles can be lifted automatically if the load on the axles is less than the maximum allowable axle load.

It may be necessary for the operator to manually intervene the axle lift with a departure help aid or maneuvering aid.



In order for the departure aid to be activated (raising the axle), the vehicle must be slower than 30 km/h and the technical capacity of the axles must not exceed 30%.

When the vehicle is stationary, it is possible to activate the traction help by pressing the tractor brake pedal 3 times in a row.

If your vehicle has optional axle lifting feature from tractor cabin, it is possible to manually lower/ raise the axle lift with a spring loaded button to be installed in the tractor cabin. For this feature, your tractor must be adjusted according to the tractor.

It is also possible to activate /deactivate the axle lift with the help of the button on the trailer.

Driving assistance can be activated by pressing and holding this button for less than 5 seconds. If it is pressed more than 5 seconds, the axle can be lowered to the ground.

You can also find information on how to use the axle lift control on the driving aid sticker on your vehicle.



As a result of intervention in the axle lift parameters, your vehicle may be out of regulation. For this reason, the EBS modulator should not be interfered with except authorized services.



Axle lifting device

- 1- ECAS Control box
- 2- Joystick
- 3- Axle lifting / lowering



Axle lifting



There is a danger of being pinched and injured when lowering/raising the axle.

3.7.2. Hubodometer

Hubodometers show the distance traveled by the vehicle in kilometers or miles.

The unit of the hubodometer is written on the hubodometer. It is adjusted according to the tire diameter.



Digital hubodometer



Analog hubodometer

3.8. Tires

When you are choosing tires, the first criteria are the load capacity index. Be sure that the load capacity index is suitable for your vehicle.

Tire manufacturers produce different types of tires according to the purposes of their use such as highway use, off-road or mixed-use. Please choose the correct type of tires according to the road conditions that you will use the vehicle. Choose the low decibel as soon as possible version. Tires as possible as having to Class A fuel efficiency level and braking on wet surfaces according to EU tire label stickers.



You can access the EU tire label values of the tire used in your vehicle on our website.

In dual/twin line wheeled vehicles, the tires must be matched properly according to their diameters. The tread depths on the adjacent tires shall not be different more than 5 mm. Furthermore, the newly coated tires and partially worn tires shall not be used side-by-side in relation to the structure and type of the vehicle. Otherwise, driving safety will be disrupted. In such tires, though the tread depths are seen, it must be deduced that the tire diameters are different and the tires exceeding the radius differences by 10 mm must not be used side-by-side.

Wrong matching will lead to excess shape deformation of the larger tire by carrying more load than necessary. In such a case, the wearing will accelerate and reveal the risk of early wearing of the tire. This case must be considered whenever radial and transverse layered tires are used side-by-side.



Tires



In some countries, seasonal use of M+S (Mud and Snow) or 3PMSF (3 Peak Snowflake) may be mandatory. In the country of driving, this etc. Tire regulations must be observed.



M+S and 3PMSF symbol



Very serious accidents can occur if unsuitable or worn tires are used.

3.8.1. Tire Pressure Monitoring System (TPMS)

It is a Tyre Pressure Monitoring System that increases fuel efficiency and extends tyre life in accordance with the R141 Regulation. In case of tyre pressure differences, it shows the low pressure tyre on the truck. OptiTire helps the driver to reduce fuel costs by providing constantly updated tyre pressure information from each monitored wheel.

A Tire Pressure Monitoring System (TPMS), which complies with regulations and helps improve fuel efficiency and extend tire life, may be available on your vehicles. In the event of an increase or decrease in tire pressure, and if the tractor unit is compatible with this system, a warning light will appear on the tractor's display.

Thanks to this system, sudden changes in tire pressure can be monitored instantly, helping to prevent potential risks. By keeping the tire pressure under control, it enables savings on fuel and fuel-related costs. It reduces emissions and helps extend the service life of the tires.

It also allows the vehicle to accelerate more easily and contributes to improved overall performance.

 Please inform your service provider about the sensor during tire replacement or repair. Otherwise, the sensor may be damaged.

 The vehicle must always be used with the original tire size. If any changes are made to the wheel or tire size, you may need to contact an authorized service center to have the TPMS recalibrated.

 The theoretical lifespan of tire pressure sensors is 5–7 years. This is because the sensors are exposed to corrosion, shocks, and high speeds during highway driving. In the event of a malfunction, you should contact a professional to have the faulty tire pressure sensor replaced.

 Your spare tire may not be equipped with a tire pressure sensor. Therefore, when the spare tire is installed on the vehicle, the tire pressure sensor from the removed tire should be transferred to the newly installed tire and recalibrated accordingly.



TPMS

TPMS

Benefits

- Sudden changes in tire pressure can be monitored instantly and risks can be prevented.
- It allows you to save fuel and fuel costs by keeping tire pressure under control.
- It reduces emissions.
- It helps to extend the life of tires.
- It provides easy acceleration of vehicles and helps increase performance.

How to set TPMS?

You don't need to do anything special, because the warning system is set to the optimum pressure for your tires. When one of your tires is underinflated (i.e. its pressure is less than 20% of the recommended pressure), a light will appear on your dashboard. This is your TPMS, indicating that the tire on your vehicle is affected.

When should TPMS be recalibrated?

If you choose a different tire size, it is possible that the recommended pressure may differ from the original tire.

In this case, a professional will need to recalibrate the TPMS so that it alerts you to any pressure drops with this new configuration.

Tire pressure sensor replacement

The theoretical life of tire pressure sensors is 5-7 years. This is because tire pressure sensors are exposed to corrosion, shock and high speed during highway driving.

In case of a malfunction, you can contact a professional to replace the faulty tire pressure sensor.

3.9. Spare Wheel Holder

Different type of spare wheel holders is optionally offered in our vehicles.



Make sure that you put the necessary warning signs and take the safety precautions during the tire change.



Driving with insufficiently secured spare tire (s) can occur accidents.



The tires are heavy parts. Be careful about ergonomics and occupational health and safety rules during the tire replacement. There is a risk of pinching, falling, and cutting.



Spare wheel holder carriers are designed for special tires dimensions. Follow the rules and regulations when removing/mounting or maintaining the spare tire or spare wheel holder.

3.9.1. Crane Type Spare Wheel Holder

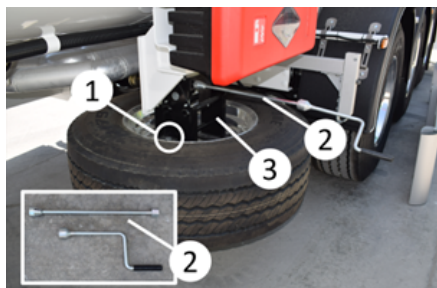

Crane Type Spare Wheel Holder

Removing the spare wheel:

- Remove the screws (2).
- Mount the lever (3) and turn it counterclockwise slowly. The spare wheel will be lowered.
- Remove the fixation parts (4) and take the spare wheel.

Placing the spare wheel:

- Mount the fixation parts (4) to the tire.

- Lift the tire upwards by turning the handwheel (3) clockwise.
- Turn the lever (3) clockwise and the tire will be lifted.
- Mount the screws (2) and fix the tire.
- Remove the lever (3) and store in the toolbox or cabinet.

3.10. Mudguards

Your vehicle has mudguards and mats in accordance with legal regulations. This equipment prevents water and similar substances on the ground from splashing onto other vehicles.

Some vehicles may have folding mats to prevent the mat from rubbing against the ground in the event of a crash.



Mudguards





Folding mats must be in the open position while driving.

3.11. Wheel Chock

There are two units wheel chocks and holders in the vehicle.

 The vehicle must be secured with wheel chocks when parked on a slope area, during the loading and unloading operations or when parked without a tractor.

 Only place wheel chocks on wheels on fixed axles, never on idle/steer axles.

 When the wheel chocks is fixed inside the holder, be sure that the pins will be mounted properly.

 After driving operations, place the wheel chocks properly.

3.11.1. Pin Type Wheel Chock Holder

Removing the wheel chock from holders: Pull out the cotter pin (1) located at the end of the wheel chock holder. Then take the wheel chock from its slot by pulling it sideways from the wheel chock holder.



Pin type wheel choke holder

Placing the wheel chock from Its holder: Place the wheel chocks on the holders and mount the cotter pin (1) to pin.

3.11.2. Pocket Type Wheel Chock Holder

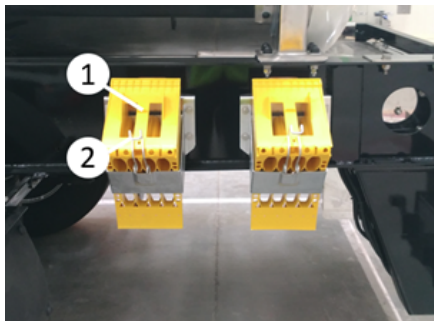



Pocket type wheel chock holder

Removing the wheel chock from holders: Remove the wheel chocks by pushing the handle (1) which is located at the end of the chock's holder from the wheel chock to the other side.

Placing The Wheel Chock from Its Seat: Insert the wheel chock by pulling the handle (1) which is located at the end of the wheel chock's holder.

3.12. Boxes and Storage Units

 Be sure that the boxes and storage units are properly closed and that the materials inside of these storage units are fixed properly before driving. Otherwise, the accident may occur.

 Be sure that the necessary safety measurements are taken while using the cabinets and storage units.

3.12.1. Aluminium Toolbox

Aluminium toolbox is used to store tools. Vehicle keys, vehicle files, etc. items are given in this box as standard. It is mounted on the left side of the vehicle, just behind the rearmost wheel, but its location may vary depending on the vehicle's construction. The cover of the toolbox (1) can be opened parallel upwards (2), or in the hinged version it can be opened to the side (3).

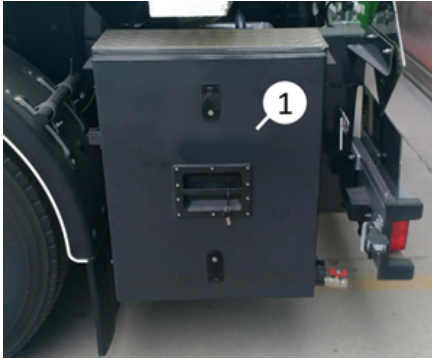

Toolbox



Toolbox cover opening sideways



Toolbox cover opening parallel upwards



Opening the lock

Opening box cover:

- Insert the key into the lock and turn both locks to open.
- After unlocking, press the button (1) on the cabinet handle.
- Pressing the button makes the lock pop out (thumbnail).
- Open the cover upwards by holding the handle. (In the bus cover system)

Closing box cover:

- Press the cover down to fit it into the lock.
- Press the lever forward and lock.
- Finally, lock the cover with the key.



After making sure that the tool cabinet is completely closed and safe, start driving. Falling parts can cause a traffic accident.



Fire extinguishers must be maintained regularly, and their expiration dates must be observed.

3.12.2. Plastic Toolbox



Plastic toolbox



Plastic toolbox

Unlocking The Toolbox:

- Remove the lock cover.
- Unlock by turning the key.
- Pull the lever towards you.
- Turn the lever and open the cabi-net door.

3.12.3. Fire Extinguisher Cabinet

Fire extinguisher cabinets are used to protect fire extinguishers from the external environmental factors.



Fire extinguisher cabinet

Opening The Cover:

- Open the 2 plastic latches (1) which are holding the cover.
- Lift the latches up and back and open the cover.
- Remove the re-closable fasteners (black tape) in the fire extinguisher box and take the fire extinguisher.

Closing The Cover:

- Insert the fire extinguisher and fix it with re-closable fasteners (black tape).
- Close the cover first and after that put the latches to the top of the cover.
- Close the latches and lock the cover.

3.12.4. Water Tank

The vehicle may have a water tank for general cleaning purposes. You can turn the tap and open the water. You can fill the water tank with the help of the filling neck which is located at the top of the tank.

There may be a soap dispenser on the water tank. You can disassemble and fill the soap dispenser by turning it counterclockwise.

 **Please be careful about the hygienic rules and regulations. The wastewater must be disposed of in accordance with the regulations of the country that you will be in.**

 **The water in the water tank should not be drunk. It should be only used for cleaning purposes.**

 **In cold weather, the water tank should be emptied. Otherwise, the water tank may be cracked because of the freezing water.**



Water tank

3.12.5. Document Box

You may store your non-valuable documentation in the round or square type document box.

You can turn the cover of the round type document box counterclockwise and open the document box.

You may lift the pin of the square type document box and remove the pin. The cover of the square type document box may be opened.

 **Store the locking pin and the document box cover properly. Otherwise, it might be lost.**

3.12.6. Armature Box

The armature box is closed by a cover. This cover is bus cover type. It opens upwards.

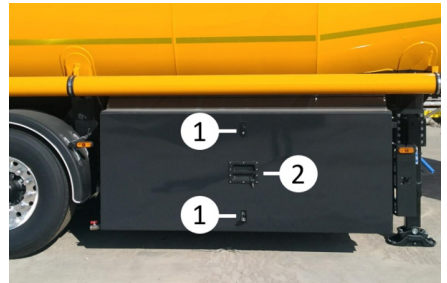

Armature box

Opening the box cover:

- Insert the key into the locks and turn them to unlock.
- After unlocking, press the buttons (1) on the lock levers.
- Pressing the button makes the lock lever come out.
- After the lock lever come out, lift the cabinet door upwards by holding the handles (2) on both sides.

Closing the box cover:

- Slide the cover downwards into the lock.

- Press the lock lever forward and lock.
- Finally, lock the cover with the key.

3.12.7. Hose Carrier

As standard, DN200 – 5 m hose carrier (1) with rear cover is provided on the right and left. Optionally, the cover can be placed on the front or on both sides. Cover keys are supplied in the tool cabinet. An optional in-chassis hose carrier is also provided (2).



Hose carriers

 Do not forget to close the covers of the hose carriers before driving. Hoses can fall, causing injuries and accidents.

 Prevent the fuel remaining in the discharge hoses from dripping onto the ground. In case of dripping into the chamber, valve can be used to drain the liquid.

3.13. Working Lamp

In fuel tankers, it is usually placed next to the armature box (1).

Its location may vary depending on the construction of the vehicle and the customer's request. It is used to light up the operation area in filling and discharging operations.

The lamp can rotate where it is in order to use the lamp more comfortably and in

a larger area. The lamp is usually turned on and off with the help of the switch (2) placed in the armature box.

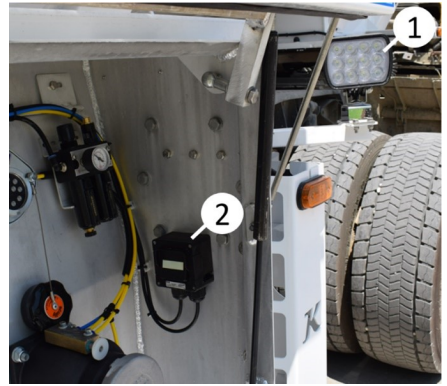

Working lamp and switch

Optionally, the work light switch (3) can also be supplied behind the work light.



Working lamp and switch

 Do not start driving without fully securing the working lamp with the lock-latch mechanism. Otherwise, the lamp may be thrown while driving and cause injury.

3.14. Grounding Pins

Grounding pins (1) according to DIN75013 are present on the vehicle in order to ground static electrical loads on the vehicle and prevent a possible fire or explosion, during filling or discharging of the vehicle. Location of these pins are marked with the sign shown on picture (2).

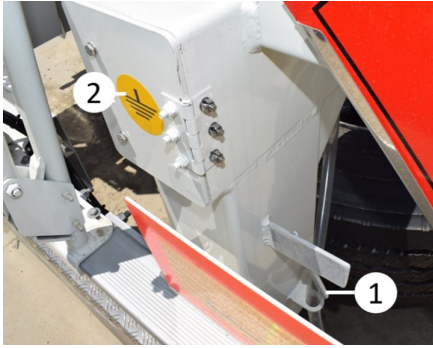

Grounding pin

3.15. Warning Signs

Warning signs (3) are present on different places of vehicle.



Warning signs



Please pay attention to that warning signs on the vehicle are always visible. Replace worn out, damaged or not visible signs immediately.

3.16. Rear Bumper (Rear Protection Equipment)

Your vehicle has a rear bumper (rear protection equipment) in accordance with legal regulations.



If you drive with a damaged bumper, traffic safety is to be compromised. And if anyone hits your vehicle from the rear side, the size of the accident will be bigger. That's why, the damaged bumper must be replaced with the original one quickly.

3.16.1. Fixed Bumper Tanker vehicle bumper

1. Side marker lamps
2. Lamp group
3. License plate location
4. License plate lighting
5. Warning signs

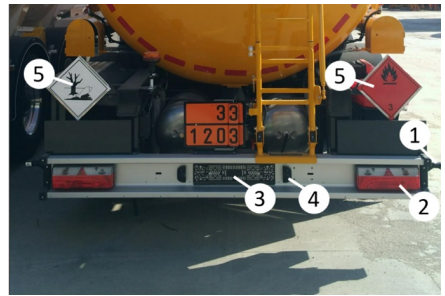

Fixed bumper

3.16.2. Reverse Audible Warning System

It is an audible warning system that is activated when the vehicle is shifted into reverse gear. It is typically mounted on the vehicle's bumper area. The system can be offered as an optional feature upon customer request.



Reverse Audible Warning System

3.16.3. TailGUARD

When the truck is driving back, 2 or 3 sensors Wabco Tail GUARD detects the object behind the vehicle and improve the safety.

After 9 km/h, the system will brake automatically and inform the driver. If the object is too close, the vehicle stops automatically.



TailGUARD

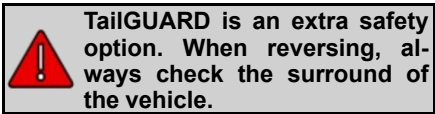

TailGUARD is an extra safety option. When reversing, always check the surround of the vehicle.

3.17. Handrail, Walkway and Ladder

3.17.1. Ladders

Vehicle may have ladders that allow us to reach some areas of the vehicle more easily are optionally available.

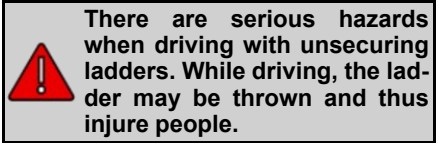

There are serious hazards when driving with unsecuring ladders. While driving, the ladder may be thrown and thus injure people.

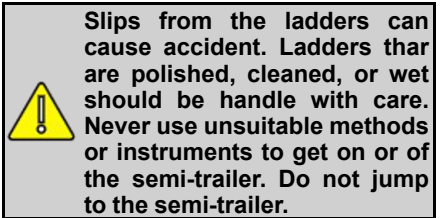

Slips from the ladders can cause accident. Ladders that are polished, cleaned, or wet should be handle with care. Never use unsuitable methods or instruments to get on or of the semi-trailer. Do not jump to the semi-trailer.

There are two types of ladders in the vehicle.

- Foldable Ladder
- Fixed Front Ladder

3.17.2. Foldable Ladder

There are minor construction differences between the ladder systems in STB, TAU, STH tanker vehicles. In fuel oil (STB) tankers, the ladder is generally located at the rear of the vehicle (1) and the bottom of the ladder is foldable for convenience and safety. In terms of compliance with UVV rules and depending on the customer's request, the folding ladder is attached to the handrail next to the upper walkway. Thus, with the opening of the folding ladder, the handrail also opens.



Foldable ladder

Opening the ladder:

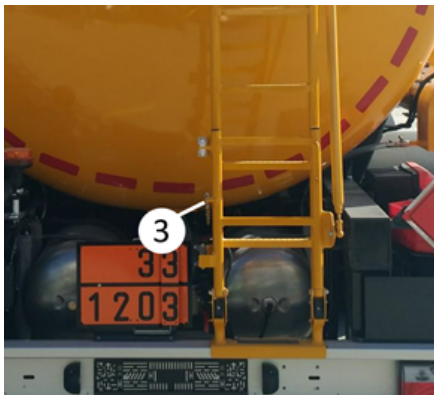

Pin

Pull the ladder toward yourself by putting it above and release it from its lock pin (3). Open the unlocked ladder pulling downwards.

Closing the ladder:

Lift the ladder upwards by holding from its bottom part. Fix the ladder by inserting the lock pin mechanism which is installed on fixed part of ladder, in its place.



Do not drive with ladder that is not secured by lock pin mechanism. Otherwise during driving the ladder can swing about, possibly injuring people in this way. The vehicle will not move when ladder / handrail is open.

3.17.3. Fixed Ladder

The ladder used to climb to the top of the vehicle is manufactured for easiness and safety. In terms of compliance with UVV rules and depending on the customer's request, the front ladder is connected to the upper walkway. In this way, access to the vehicle is provided via a fixed ladder.

3.17.4. Left Handrail

It is at the side of walkway on the upper part of the vehicle (5). It is necessary for secure operations on the vehicle. When the guardrail is opened, park brakes of vehicle will be enabled, when guardrail is lowered park brakes are disabled by means of sensor mechanism (4) connected to guardrail.

Opening the handrail:

Pull the pin (1) that fixes the guardrail. Afterwards lift the guardrail by holding the arm (2) on the guardrail. Fix the lifted guardrail with anchor pin (3). Close the guardrail make these processes in reverse order and fix with pin.

In some model STB-TAU-STH vehicles, the mechanism (4) is in the rear ladder (6) area.

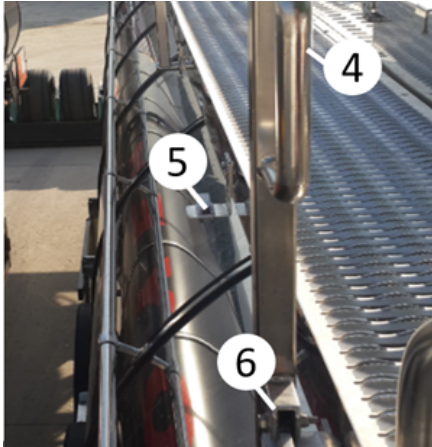

Opening the manual handrail:

Closing the manual handrail:

Lift the lock bracket upwards, grab the handle of the handrail and push it forward. Secure the handrail by replacing the latch mechanism.



Handrail assembly



Valve mechanism

3.17.5. Rope

Rope (1) is mounted on the guardrail. It is installed to prevent falling down of persons operating on top.

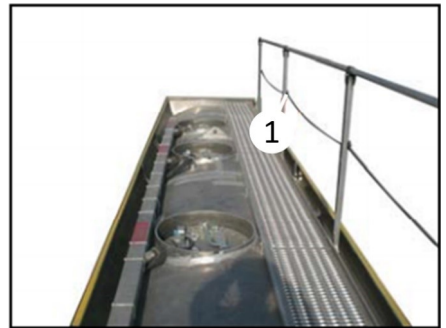

Rope

4. UPPERSTRUCTURE COMPONENTS AND USE

In this chapter, components of upperstructure of the tanker and their use will be explained. It is very important to understand the use and purpose of these components to achieve loading and unloading securely. For this reason, before loading and unloading processes, please read this chapter carefully and follow the instructions.

This chapter starts with an overview of upperstructure components and continues with description of using of these elements in detail. Equipment in fuel tankers are described in this chapter.

4.1. Overview to the Upperstructure Components on Tanker

Component	Function
Tank	It is the main structure that is separated from each other by walls, has breakwaters and cambers that prevent surges, consists of aluminum and carries dangerous liquid material.
Manhole cover	It is the structure which allows filling from top with different equipment on it.
Filling cover	It is the cover which allows filling from top.
Pressure vacuum safety valve / Flame protection	It prevents existing negative and excess pressure inside the tank.
Level sensor (Electronical float)	Controls the filling level of the fuel in the tank, sends a signal to the socket in the armature box cabinet.
Safety type manhole neck	Helps to reduce the damage of manhole cover to minimum against falling over the vehicle.
Lifting eye bolt	It is used for loading the tank to vehicles such as RO-RO, trains or lifting it with a crane after an accident.
Armature (filling/discharge) box	It is the box where connection elements and couplings are present during filling and discharge of the tank.
Emergency button	Supplies closing of all bottom valves in case of emergency. It is located on the rear, right and left sides of the vehicle.
Ladder	It is used to climb to the top of the tank.

Handrails	It is used for walking and holding on to the walking path safely.
Grounding pin	There are a total of 4 grounding pins in the landing gear area and the rear chassis area.

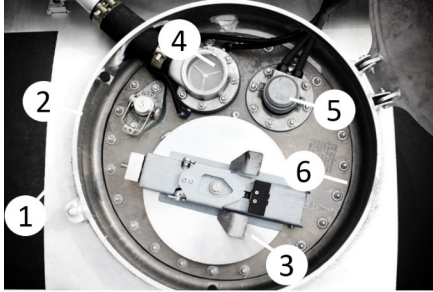

Manhole area

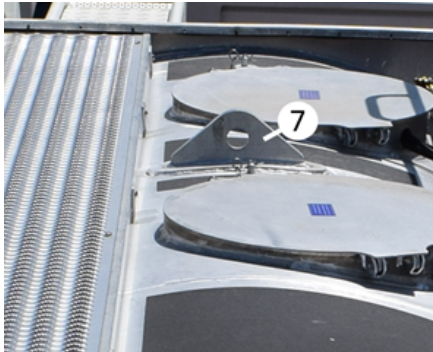

Lifting eye bolt



Emergency button

Tank

Tank is manufactured from aluminium and may be manufactured with different numbers of compartments upon the

request of the customer. In each tank compartment, following structures exist;

- Separation wall
- Breakwater (if necessary)
- Manhole
- Level bar
- Level sensor
- Pressure vacuum safety valve

Separation wall:

It is the wall that separates each compartment of the tank. It enables transporting of different fuel types (benzine, diesel fuel etc.) in different compartments of the tank.

Breakwater:

It is the wall similar to separation wall that enables passing of fuel from center. It prevents floating of fuel inside the tank during sudden brake or accelerations. This type of floatings may result in change in the center of gravity of the vehicle and worsen road grip and control.

Other parts will be mentioned on section of “**Manhole Cover**”.

4.2. Filling and Discharging System

4.2.1. Manhole and Manhole Cover

Equipments on the manhole cover:

1. Manhole
2. Manhole cover
3. Filling cover
4. Pressure vacuum safety valve

5. Level sensor (Electronical float)

6. Level bar

7. Safety type manhole neck

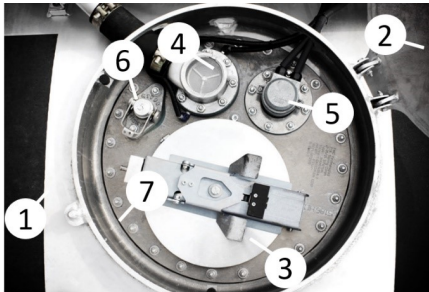

Manhole area

Manhole:

There is one manhole on the top of each tank compartment. Manholes for filling are inside the security type manhole neck (1) and covered with safe closing manhole covers. Manhole cover is opened for filling from top, control and service purposes.

Manhole cover:

It is the structure that houses various equipment on the manhole cover. It is screwed on the manhole neck. The equipments on the manhole cover and their usage purposes and shapes are as explained on the next page.

Filling cover

Used for filling of tank from top.

Opening: Release the locking lever by pressing spring lock mechanism (A) as shown in the figure. Tilt the released locking lever backwards 180 degrees and release the opening lever (B) from the locking lever. Open the filling cover by lifting the opening lever.

Closing: Close the filling cover following the opposite sequence.

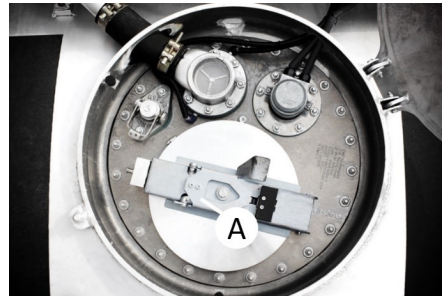

Spring lock

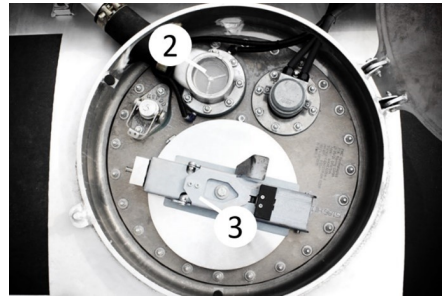

Lock arm



Be sure that the filling cover is closed completely and locking lever is fitted to spring lock mechanism. Do not close with feet while the mechanism is open, do not damage the gas-kets. Do not warp the pin.

Pressure Vacuum Safety

Pressure vacuum valve (2) is an important protective equipment. Prevents the negative and positive pressure arised by the variatios on air pressure and temperature inside the tank and prevents damage on tank due to this pressure. As a standard, it is installed on manhole cover.

Over Filling Security Sensor (Electronic Float)

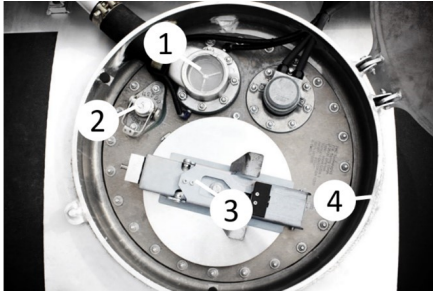

Manhole area

In case fuel level reaches to the max. filling volume of compartment during filling from bottom, fill process will be stopped with electro-pneumatic switch in socket that is in armature box and receiving signal from sensor. Protection against over filling of the tank can be realized. If it is empty, it sends a signal to the device in the station before filling, informing that it is ready for filling.

Level Bar

Indicates fuel level inside the tank. Net volume is marked on the bar (2). It is optionally calibrated. Calibrated top line showing net volume is standard. In order to open, lift the pull lever (3) 90 degrees and release it from the latches and take the level bar for control. You can control the filling level on a volumetric basis.

Safety Type Manhole Neck

It is the circular structure (4) around the manhole. It is designed to reduce the damage on manhole cover and other mentioned equipment and reduce the spilling of fuel when manhole cover is opened to the minimum, in case of falling over of the vehicle. The filler neck is supplied as standard. It is welded to the tank.

4.2.2. Armature (Filling / Discharge) Box

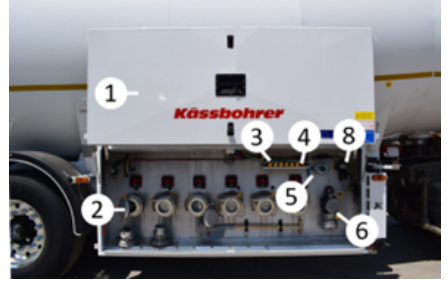

Armature box

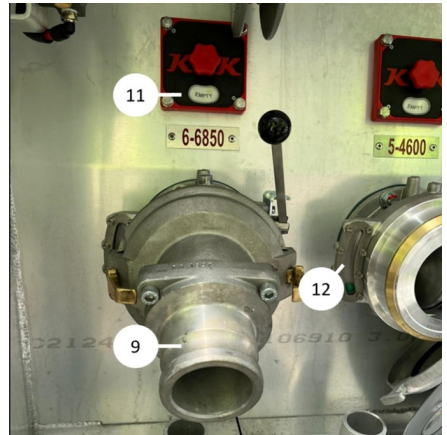

API Couplings

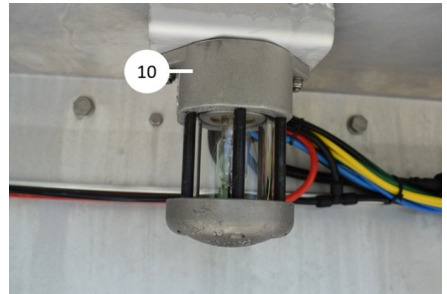

Ex-Proof lamp

The armature box contains filling-discharging connections, filling controls, additional operating controls as well as some hoses and accessories. Filling-discharging operations of the tank are carried out thanks to the equipment in this box. Filling-discharging can be done automatically by the controls inside this

box. Components found inside and above that box are described below:

1. Armature box cover
2. API couplings and dust covers
3. Pneumatic bottom valves control block
4. Emergency button which closes all bottom valves
5. 'J' type channeled over filling socket
6. Gas return adapter, with interlock system
7. Park brake activation sensor
8. Air conditioner
9. Discharge adapter
10. 'Ex-proof' lamp for lighting inside the box and on-off power switch.
11. Turning product presentation apparatus
12. Inspection window
13. Bucket, shovel and copper hammer

4.2.3. Armature Box Cover

This cover is bus type cover. It opens upwards.



Armature box cover

Opening the box:

- Insert the key and turn it to open the locks.
- After unlocking pull the buttons (1) on the lock handles.

- With pressing the button, the lock handle gets out.
- After lock handles have got out, lift the box cover by the handles (2) on both sides.
- **Closing the box:**
- Lower the cover and place into the lock.
- Pull the lock handle forward and lock it.
- At last lock the cover with key.

4.2.4. API Couplings and Dust Covers

They are filling-discharge connections in order to discharge and fill the tank compartments from bottom. Each tank compartment has its own API couplings (3).

There are same number of API coupling with the number of compartment. If API couplings are not used, they are covered with 'Dust Cover' to prevent entering dust, dirt etc.

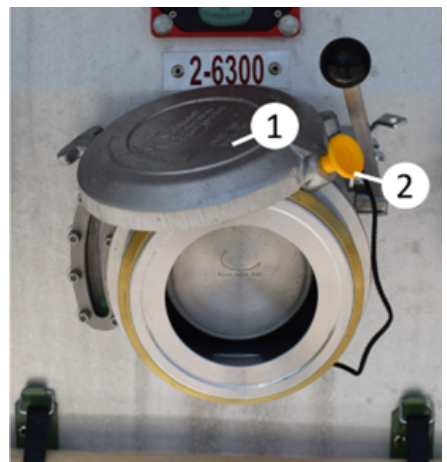

Dust cover



API Couplings

Dust Covers

These covers prevent entering dust, dirt etc. to API couplings. They should be removed before filling-discharging processes and fitted again after completion of process. It can also be used for sealing.

Removing Dust Covers:

Take out the cover by opening the latches on the coupling pulling yellow lever (2) on the dust cover. Cover is connected to the coupling via a rope which prevents falling down and getting lost of the cover.

Installing of Dust Cover:

Place the cover on the coupling and lock to the latch.

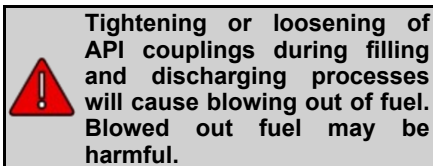

- Never loosen the couplings during filling and discharging.
- Do not approach fire, open flames and do not use spark producing tools around the couplings.
- Always connect the grounding pin.
- Be sure that couplings are connected safely before filling and discharge processes.

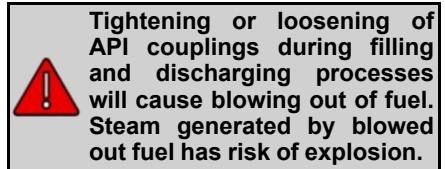

- Never loosen the couplings during filling and discharging.
- Be sure that couplings are connected safely before filling and discharge processes.

4.2.5. Pneumatic Bottom Valves Control Block

Buttons on this block (1), control pneumatic bottom valves. Valves of related compartment or compartments can be opened using pneumatic control block and will be ready to fill. If the pneumatic installation pressure is lower than 3 bars, the bottom valves do not function. Operation pressure of bottom valves is between 3-6 bars. If the bottom valves control button is pulled, it stays as pulled; this shows that these valves are left open.

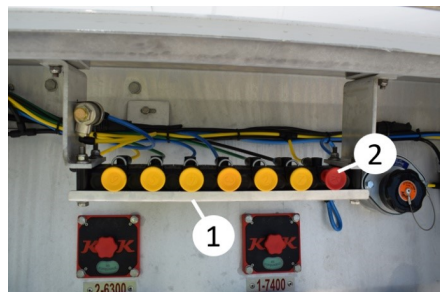

Pneumatic control block

4.2.6. Emergency Button Which Closes All Bottom Valves

In case a problem has occurred during filling, bottom valves can be closed by pushing 'red' coloured or K button (2) on the bottom valves control block, filling can be stopped.

4.2.7. Turning Product Presentation Apparatus

It is a rotatable product display apparatus (1) that informs the operator with the product labels in its internal structure. The operator can see what is in the volume by selecting and changing the fuel types he fills here. It can be side or middle controlled types. It is placed near the API coupling of each compartment. It can be manually adjusted to show which type of fuel (diesel, gasoline, etc.) is filled in that compartment by turning it with the help of the rotary knob located on the right or middle side.

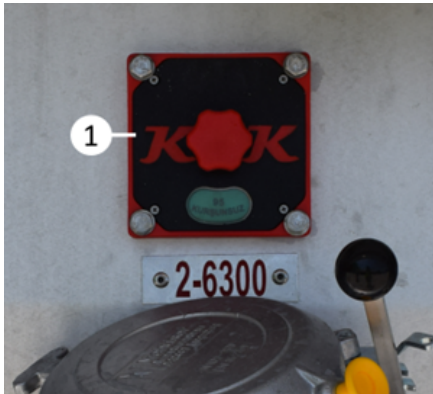

Product presentation apparatus

4.2.8. 'J' Type Channeled Over Filling Socket

The "J" type channeled overfill socket (1) is usually located in the armature box, but its location may change in the box depending on the construction of the vehicle.

During the filling and emptying of the tanks, the electrical connection from the station is made via the "J" channel overfill socket for overfill protection and electrical earthing. Thus, overfill protection is realized. The number of J is 4 as a standard, and 3 in some countries. It is with 10 pins as standard. According to the countries, 6 pins can also be given. There is an electro-pneumatic switch inside. It electrically receives the full-empty information from the optical sensor, and

also allows the bottom valves to be closed.

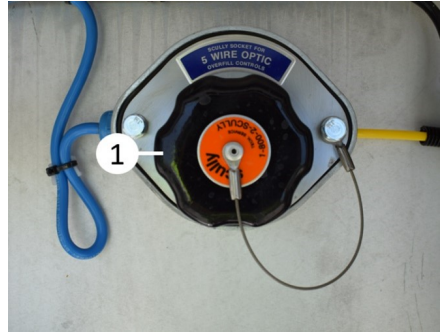

J type over filling socket

4.2.9. Gas Return Adapter, With Interlock System

In order to recover the fuel steam during filling, fuel steam recovery is performed by connecting the relevant installation at the station to the steam adapter present on the vehicle. In some countries, it also connects during discharge and reduces the dangers by keeping the steam of the fuel away from the working area during filling-discharging. When pressed to the interlock valve (2) from the filling station, it opens the valves and makes the vehicle suitable for filling.

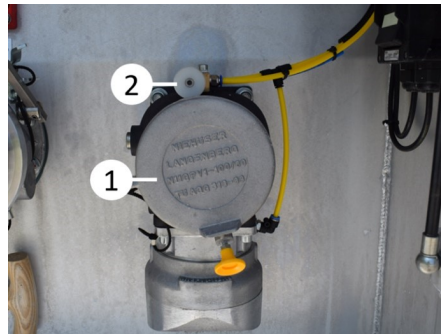

Gas return adapter

4.2.10. Park Brake Activation Valve

When the armature box cover is opened, there is a pneumatic valve (1) that automatically activates the parking brake.

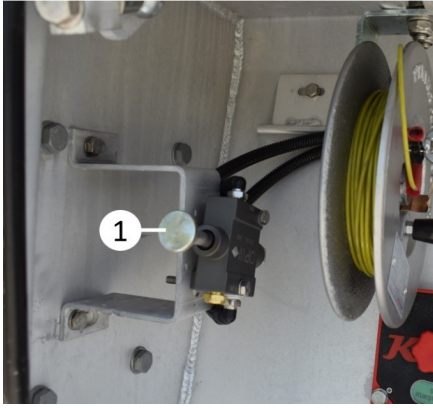

Park brake activation valve

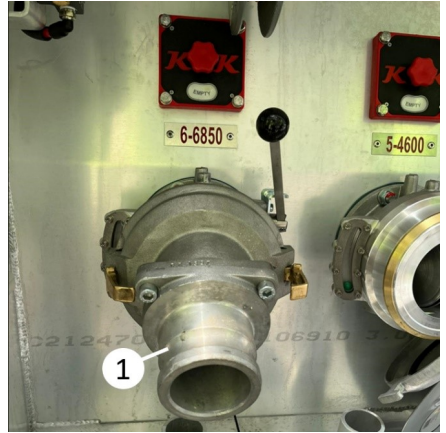

Boşaltım adaptörü

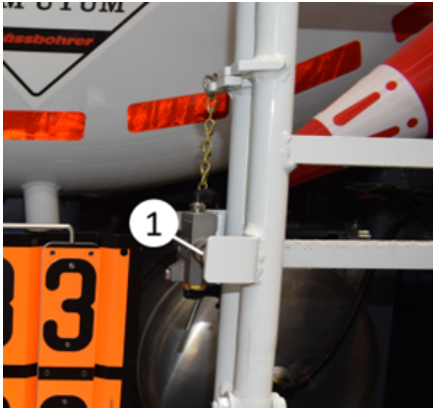

Park brake activation valve

4.2.12. 'Ex-Proof' Lamp For Lighting Inside the Box and On-Off Power Switch

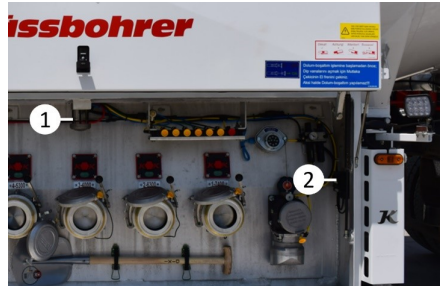

'Ex-Proof' lamp and on-off power switch

4.2.11. Discharge Adapter

Used for the connection of fuel hoses to API couplings for discharge purposes. Install the adapter with yellow latch lifted and after installing lower the latch and fix the adapter. Lower the lever, in order to realize discharge process. Discharge can be realized when the lever is on lower position.

There are discharge adapters with lever as well as without lever versions. There are also observable types of product flow through the observation glass.

4.2.13. Material Flow Observation Glass

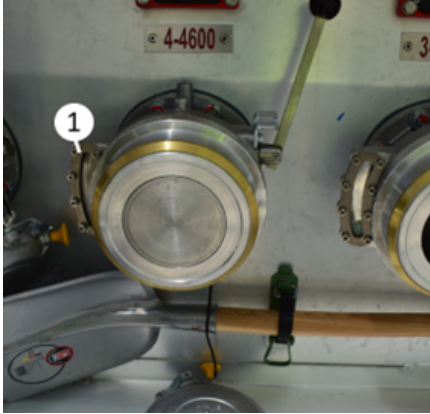

Material flow observation glass

The material flow observation glass (1) is located at the bottom right of the API couplings. It is used for fuel flow inspection, during filling and discharging processes.

4.2.14. Air Conditioner

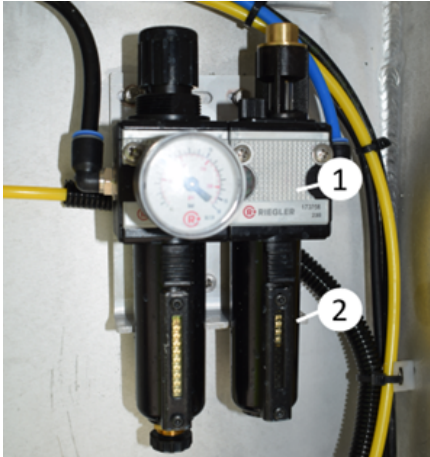

Air conditioner and oil reservoir

Air conditioner (1) is located generally in the armature box, whereas the location may vary depending on the construction of vehicle. It adjusts the necessary air for pneumatic system of the vehicle.

It shows the pressure in the system with the air manometer on it.

No. 10 oil should be put in the oil reservoir (2).

This oil protects the pneumatic elements by sending oil. Do not exceed the oil level shown in the reservoir. Do not forget to put oil at certain intervals.

4.2.15. Copper Hammer, Bucket and Shovel



Copper hammer



Bucket

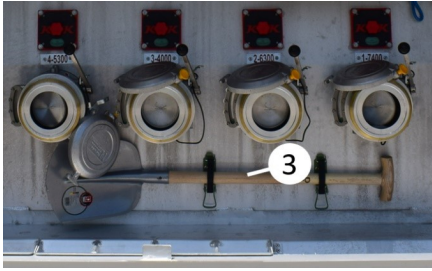

Shovel

One copper hammer (1), one aluminium bucket (2) and one aluminium shovel (3) are delivered as standard equipment inside the armature box, in order to use on vehicle when necessary. Hammer is manufactured from copper, shovel and bucket are manufactured from aluminium in order to prevent spark generation.

4.2.16. Emergency Button



Emergency button

In case a problem during filling / discharging, bottom valves are closed with the help of emergency buttons (1) present both on left and right side of the vehicle and filling / discharging process can be stopped.

4.2.17. Measurement Systems

Measurement systems vary according to options. It is given by configuring according to the selected options.

4.3. Warning Labels On the Tank

On different locations, there are warning labels and plates on the tank.

Some of them are;

1. Warning for flammable material
2. Emergency button
3. Product plate indicating the transported material



Warning plate, emergency button label



Warning plate, ADR plate

4.4. Product Plate Indicating the Transported Material

A plate (3) is installed on the back of the vehicle, indicating the material being transported. Mobile plate can be changed according to the transported material.

4.5. Lifting Eye Bolt

They are the lifting handles (1) with sufficient endurance in case tank will be loaded to vehicles like train, RO-RO etc.. Two eye bolts are installed at the top of the tank.

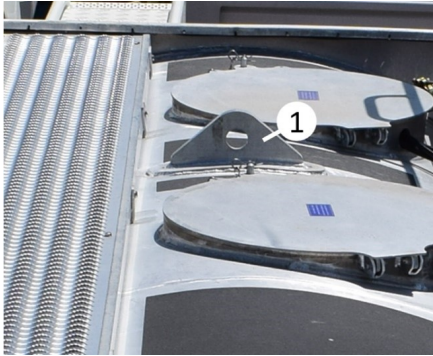

Lifting eye bolt



Do not lift the tank from any other location than eye bolts. Otherwise you could damage the tank and may cause injuries even death.



Lifting eye should only be used when the tank is empty.

5. TRANSPORTATION PROCESS

5.1. Pre-Driving Checks

- All necessary documents are in the vehicle,
- Required adjustments and suitability of the loading situation,
- The vehicle is properly tied and secured to the tow truck.
- All pneumatic and electrical connections between the semi-trailer and the tractor are made properly and the EBS system is in working condition,
- All necessary equipment (chocks, underrun protection, ladders, etc.) is in place and properly locked or secured,
- The loads are correctly distributed to prevent displacement while driving,
- The load weight is within the allowable limits,
- The regulations of the country you are in are complied with,
- The lighting and signal system is fully functioning,
- Tire air pressures are at the required level,
- Check that the parking brake of the semi-trailer is released.
- All valves and manhole covers are closed and secured,
- The material hoses are safely lifted.

5.2. Semi-Trailer and Tractor Coupling

Apply the following steps to couple the semi-trailer with the tractor:

- Check that kingpin and its couplings are normal. Make sure that there is an adequate amount of grease oil

on the fifth wheel, top-connection plate and kingpin that will ensure undamaged coupling and not contain any dust and contaminant.

- Lower the height of the rear suspension airbags of the tractor until it can be inserted in the king pin section of the semi-trailer.
- Set the 5th wheel locking system on the tractor to the "On" position.
- Adjust the height of the semi-trailer to insert it into the tractor. The height of the semi-trailer can be adjusted with the mechanical landing gear. Prevent the movement of the semi-trailer by using the parking brake. Put wheel chock at the rear of the wheels for safety.
- Move the tractor, fifth wheel until it touches the top-connection plate of the semi-trailer and moves backwards slowly on the same level. The fifth wheel will slide smoothly under the top-connection plate and enter the kingpin's shoes and lock automatically with the intensity of impact.
- Raise the landing legs of the semi-trailer and insert the landing legs arm to its place.
- Connect the air, electrical and EBS cable and hoses to their places on the tractor. Be sure that all the functions are working properly.
- If the vehicle has a parking brake, release the parking brake.



If your vehicle is driven at the wrong 5th wheel height, malfunctions may occur in the vehicle. You may have height problems. The vehicle must be driven at the correct fifth wheel height.

Apply the following steps to uncouple the semi-trailer with the tractor:

- If the vehicle is equipped with service type brake chambers, apply the parking brake after checking the brake drum. Never apply the parking brake when the brake drums are very hot. (The drum may crack.)
- If the vehicle has a hand-brake type brake, put a wheel chock in front of the vehicle. Apply the handbrake.
- Disconnect the brake air lines, the brake will be applied automatically. Disconnect the semi-trailer electrical connections.
- Lower the mechanical landing gear of semi-trailer (use high speed). When the mechanical landing gear foot or wheels touch the ground, switch the mechanical landing gear crank handle to low-speed position to raise the semi-trailer.
- Unlock the fifth wheel lock. Separate the tractor from the semi-trailer about 500 mm by slowly moving the tractor forward. Lower the level of the rear suspension airbags of the tractor and leave the semi-trailer's bottom.

To ensure that that the king pin is locked properly, engage the first gear of the tractor, and press the gas pedal, when you are slowly releasing the clutch, you will feel that the tractor strives to move the semi-trailer, this indicates that the connection is made properly. During the travel, this connection must be checked carefully to prevent separation of the semi-trailer from the tractor accidentally.

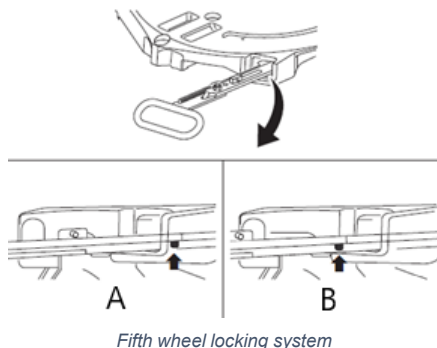
A- Locked

B- Unlocked

5.3. Cautions While Parking and Stopping

- Involuntary trailer movements, unstable posture and insufficient safety at night can cause serious accidents and injuries.
- Use the parking brake and wheel chocks while stopping.
- If you are going to park the vehicle in a public traffic area, you must use the necessary marking plate in accordance with legal regulations.

5.4. Reversing Sensor

There is a reversing sensor (1) option for blind spot detection while the tanker is backing up.



Reversing sensors

5.5. Reversing Camera



Reversing camera

Your vehicle may optionally be equipped with a rear-view camera. These cameras are activated in connection with the reverse light. An external monitor can optionally be delivered together with the trailer. You can have this monitor installed by contacting the authorized service center of your tractor unit.

In some tractor units, the trailer rear-view camera can be connected directly to the tractor's display. You can check whether your tractor unit is compatible on the camera manufacturer's website. If it is compatible, you may contact the authorized service of the camera manufacturer to perform the required synchronization process.



Your vehicle may optionally be equipped with a camera cable that runs from the rear of the vehicle to the front dashboard. With the help of this cable, you can install the camera.



5.6. Important Technical Considerations

5.6.1. Fire Extinguisher

Have fire extinguishers checked periodically every year and if necessary, fill them up. In case you use the fire extinguisher, fill it immediately.

Precautions in case of fire:

Some sealing materials let out gas when burned; these gases may become abrasive acid in contact with water, thus, never touch the fire extinguisher liquid accumulations, without wearing protective gloves.



Fire Extinguisher Box

5.6.2. Wheel Chocks

Keep the wheel chocks in their place and place them under the wheels during parking. Do not forget to pick up the wheel chocks.



Wheel chocks

5.6.3. Modifications on the Trailer

Repairing and modification operations must be made by only authorized services. Otherwise, your vehicle may be out of warranty.

5.6.4. Air Leakage

In case the air pressure in the air tubes drops instantly with the engine stop, this means that there is a leakage in the

pneumatic system. Contact the nearest authorized service in such a case. The air leakage not only affects the safety of the braking system but also negatively affects the load lifting capacity of air-bags.

5.6.5. Considerations For the Environment

In order to keep environmental pollution to a minimum, the following rules must be followed;

- Do not discharge used hub oils into drains, landfills or vacant lots. These behaviors are against the law.
- Avoid contact with vehicle oils. This can be dangerous to your health.
- Carefully collect such liquids in a safe place and hand them over to the authorities.
- For fuel tankers, immediately take necessary environmental precautions in case of product dripping or leakage that may harm the environment.

Pollution in all its forms poses a threat to the environment. To keep the pollution at a minimum, collect the waste materials carefully and dispose of them in accordance with the regulations of your country.

ENVIRONMENT - Disposal of the battery in an inappropriate place may harm the environment and human health. If you need to dispose of the battery, follow local regulations. If you do not know how to dispose of it, take it to the most appropriate service point. The symbol on the battery indicates that this product should not be disposed of.

Health and Safety -

- Keep sparks and fire away from the battery. The battery emits explosive gas that can cause an explosion.
- Wear eye protection and rubber gloves while working on the battery, otherwise the battery hand-control

may burn you and cause you to lose your eyes.

- Under no circumstances allow children to handle the battery. Make sure that anyone dealing with the battery is familiar with the proper use of the battery and its hazards.
- Pay close attention to the battery electrolyte as it contains diluted sulfuric acid. Contact with your skin and eyes may cause burns or loss of eyesight.
- Carefully read and understand this manual before working on the battery. Failure to follow instructions may result in injury and vehicle damage.
- Do not use the battery if the electrolyte level is at or below the recommended level. Using the battery with a low electrolyte level can cause explosion and serious injury.

If there are wasted oil and wasted oil contact materials in your vehicle, pay attention to the following warnings.

When disposing of products/wastes such as used oil, hydraulic oil, do not discharge into channels, sewers, landfills, or soil. This is against the legislation of all countries.

This rule also applies to empty containers in contact with oil, chemical materials, and waste of cleaning cloths. Take these wastes to the relevant authorities or the most appropriate service point for disposal.

If your vehicle tire has expired;

The end-of-life tire must be disposed of in accordance with the regulations. For this, take your expired tire to the relevant authorities or appropriate service points.

If you carry dangerous chemicals in your vehicle;

In case of an accident or emergency that may occur during transportation, act in

accordance with the Written Instructions of the ADR Legislation.

From the trailer's life-cycle perspective, it is important to recycle the end-of-life vehicle in an environmentally friendly manner. A large part of the trailer consists of recyclable materials. Contact the approved company and appropriate service for the recycling of the trailer that has expired.

5.6.6. Welding

Never do any welding work on the vehicle body and chassis. Disconnect the vehicle's electrical connection from the tractor before welding on the parts. It is recommended that you disconnect the tractor as well. Connect the minus (-) end of the welding machine as close as possible to the welded part in order to ensure sufficient contact with the part to be welded. Do not connect the negative (-) end to the bracket holders or the axle. Take care that welding sparks or slags do not fall on the bellows, air hoses, bracket holders etc.

Do not make any welding interventions to the tankers without gas-free (gas-free cleaning process) and gas measurement results without reliable gas-free certificate. Otherwise, there will be risks of explosion, fire and work accident due to the petroleum products transported.

5.7. Cleaning of the Vehicle



Entering the tanker vehicle for cleaning purposes after the transportation of certain materials harmful to human health poses serious health risks. Do not enter the tanker vehicle unless absolutely necessary. Before entering the tanker vehicle, make the necessary gas measurements in accordance with the regulations.

Ensure the tanker clean by daily inspections.

These inspections should be applied especially to connection elements and

equipment used in loading and discharging. Dirt and product residuals should be cleaned immediately. Driver compartment should be kept clean and in order.

Warning signs, notes and stickers should be kept clean. Damaged and invisible signs should be replaced as soon as possible.

After transporting of chemicals, tanker should be cleaned and ventilated as soon as possible.

 **Take attention that tanker is cleaned by authorized services specialized on tank cleaning.**

Before Cleaning the Tanker Vehicle:

- Make sure that the tank vehicle has been fully discharged and that there is no product residue left in the fittings, couplings and hoses,
- Make sure that the tank is depressurized,
- Make sure that potential conductors are connected.

 **Incompatible cleaning agents can damage the tank and its sealants. Only cleaning agents that are compatible with the tank and its sealants should be used.**

 **When a tank that has been hot-cleaned cools down, vacuum damage can occur if the tank is insufficiently vented. Make sure that there is sufficient ventilation via the man-holes and valves.**

 **Do not use the inflammable liquid or toxic substance for cleaning works.**

External Cleaning

 **Newly painted surfaces can only be cleaned after a 4-week paint stiffening period. Cleaning done before this can damage the paint. During the first 4 weeks, the tanker vehicle should only be washed with cold water jet. Do not use pressurized water jets or hard brushes.**

 **After 4 weeks: Washing painted surfaces with high-temperature water or abrasive cleaning materials may damage the paint.**

- Wash the external of the tank only with water at a temperature below 60°C.
- Do not use abrasive cleaning detergents.
- Maintain the minimum distance required when using high-pressure water jet.

When cleaning the external of the vehicle:

- Clean the outpouring load as soon as possible.
- Clean the residues of road salts regularly, as soon as possible.
- Clean the tanker vehicle once a week with a little water and a mild, non-corrosive detergent.

If you are cleaning with high pressure:

- Maintain minimum distance of 70 cm between the circular nozzle and the surface being cleaned.
- Maintain minimum distance of 30 cm between the flat nozzle and the surface being cleaned.
- Do not direct water on electrical components, receptacle connections, seal rings or hoses.



Do not use the inflammable liquid or toxic substance for cleaning works.

6. TRANSPORTATION SOLUTIONS

6.1. Fuel Tankers Sealing Points

In order to seal a semi-trailer after filling;

- 1- The dust cover must be sealed.
- 2- The armature box door must be sealed.
- 3- Level control stick must be sealed.
- 4- Manhole cover spring lock must be sealed.
- 5- The manhole sealing cover must be sealed.

 **The positions of the sealing points of the dust cover may vary depending on the brand.**



Sealing armature box cover

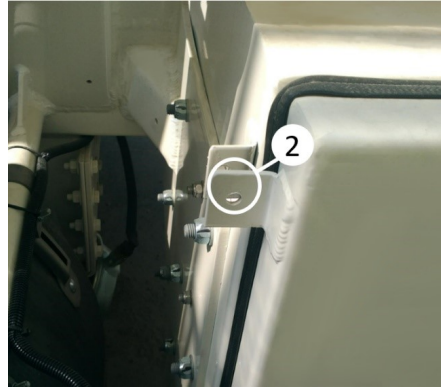

Sealing armature box

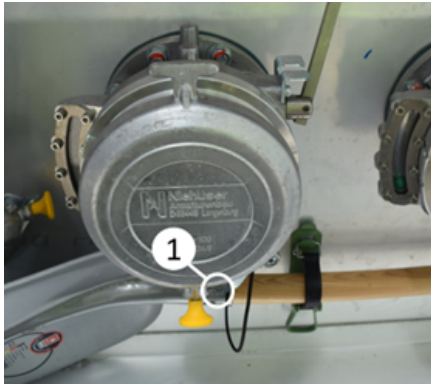

Sealing dust cover



Sealing level measure stick

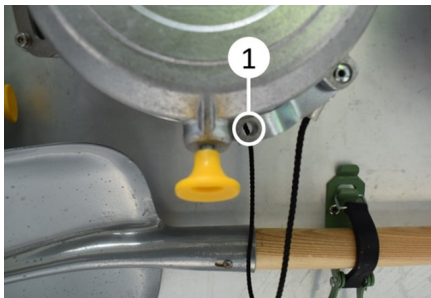

Sealing dust cover

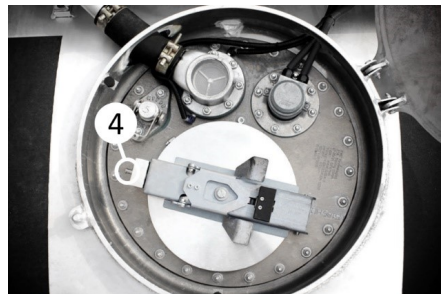

Sealing spring lock

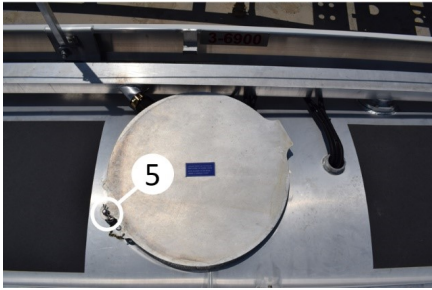

Manhole sealing cover



Manhole sealing cover

6.2. Dangerous Goods Transportation (ADR)

Vehicles carrying dangerous goods must keep this plate in the open position while driving. It is located at the rear of the vehicle, but its exact location may vary depending on the vehicle's construction. The ADR plate is defined in the R105 legislation. Approved vehicles in accordance with ADR legislation must have an ADR identification plate.

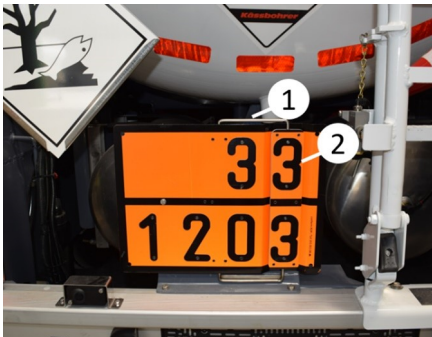

ADR plate

Opening the plate: Pull back the opened flap of the plate and push the latch back (1). By pulling the latch (2) clockwise, turn the plate according to the gasoline (1203) or diesel (1202) code to be loaded.

ADR plate is optionally supplied with folding function.

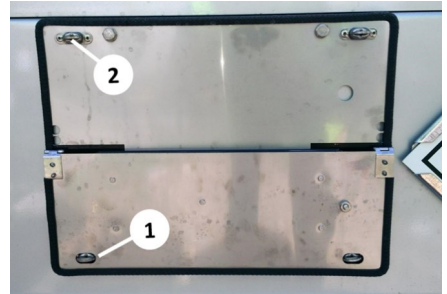

Opening ADR plate



ADR plate latches

Opening the plate: Open the plate in the closed position upwards by turning the latch (1) clockwise or counterclockwise by 90°, attach the opened flap of the plate to the latch (2) on the other side and fix it in the same way as the opening procedure.

7. LOADING AND LOAD SAFETY

7.1. Safety Instructions

- Be sure that the cargo is properly distributed and in accordance with all laws, rules, and regulations. Check the loading limits, total weight, and axle load capacities. Do not exceed the weight limits which are defined in the user manual and identification plate. Comply with all national/international laws, rules and regulations about loading and occupational safety.
- During the loading operation, do not exceed the permissible maximum height. A loading performed within the specified loading limit will ensure that you keep away from traffic accidents.

Perform the following checks after loading and unloading:

- Check that the tanker is properly filled (filling level, load distribution, etc.)
- All valves and manhole covers are closed and secured.
- All material hoses are safely removed.
- Check that the folding ladder and handrail are folded and secured.
- All danger signs are in place and visible.
- In addition to these checks, some of the equipment in the vehicle must also be checked in their manufacturer's manual.

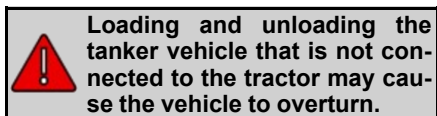

Fill or unload the tanker vehicle only when the vehicle is connected to the tractor.

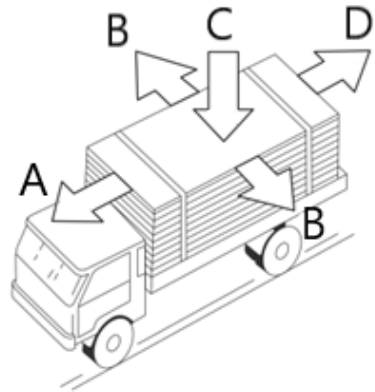

Forces may affect the vehicle

- A- Permissible front axle weight
- B- Permissible maximum weight
- C- Permissible rear axle weight
- D- Driving characteristic change limit

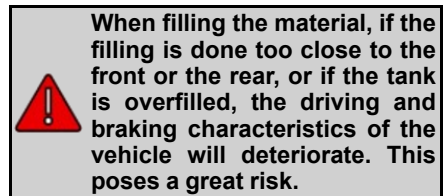

- Fill the material as evenly as possible.
- Observe the permissible tank and axle loads.
- Pay attention to the minimum and maximum filling levels.

7.1.1. Load Safety

The international Highways Regulations specify the maximum loading capacities of tractors, trucks, trailers, semi-trailers along with how and how much of the tonnage and dimensions of these loads are to be secured.

7.2. Load Distribution and Load Limits of Tractor-Semi-trailer Combination

- Ensure that you made a proper load distribution in compliance with all laws, rules, and regulations.
- In the loading process, take the loading limits, total weight, and axle load capacities into the account.
- Ensure that you have performed the loading in compliance with the laws and regulations of all countries where you drive the vehicle.

The axle loads of the tractor/semi-trailer combination may vary in a broad range in relation to the various loading conditions. Comply with the permissible axle loads specified in the operation manual or the axle manufacturer's manual.

Whenever you are in doubt, have your loads checked at a proper weighing station.

***Axle load: This is the load conveyed by an axle or an axle group.**

- **Loading and unloading of the tanker vehicle that is not connected to the tractor may cause the vehicle to tip over.**
- **Fill or empty the tank only when the vehicle is connected to the tractor.**



Follow the correct order during the filling and unloading operations. This is especially important if several loading sections are being filled at the same time. Even when filling, consider the unloading sequence so you can get to the unloading area with the right load distribution.



If the front or rear of the tank is heavy, the driving and braking characteristics of the tanker vehicle deteriorate and an accident risk arises.

- **Fill the tank evenly.**
- **Observe the permitted tanker and axle loads.**
- **Pay attention to the minimum and maximum filling levels.**

7.3. Warnings Regarding Filling and Discharging

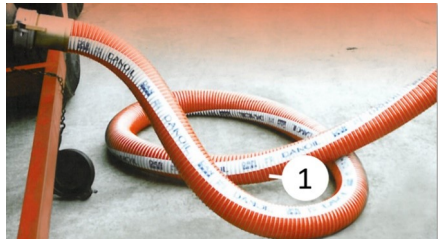

Hose

- Park the vehicle at the station with the filling and unloading connections as short as possible. Thus, the possibility of kinking of the transport hoses (1) is minimized.
- When you stop the vehicle, turn off the engine and apply the parking brake. If necessary, place chocks under the wheels.
- Follow the transporter's safety instructions before and during filling.
- Do not smoke!

- Turn off all unused electrical devices to avoid the risk of explosion. These include radios, cell phones, and auxiliary heaters. The headlights of the vehicle are also unnecessary.
- Be careful with conductive shoes and helmets, wear additional protective clothing if necessary.
- Do not carry items that may cause sparks (keys, lighters, etc.) in clothing pockets. Do not choose clothes that can provide static electricity during the operation.
- Never try to thaw frozen manhole covers with an open flame.
- Before each filling and discharging, check that all connections are secure and properly made.
- During the loading/unloading operations, the parking brake must be activated, and the vehicle must be fixed with wheel chocks.
- To prevent slipping, tipping or sinking of the vehicle, the vehicle must be parked on a flat and firm surface.
- Ensure that you made a proper load distribution in compliance with all laws, rules and regulations.
- The suspension of the vehicle may be raised during the loading/ unloading process. Because of this reason, the vehicle height may be bigger than the permitted height limits. Always set the trailer in the driving position after loading and unloading. Always check height limits when entering tunnels and passages.

7.4. Electronic Sealing System (SPD-Sealed Parcel Delivery)

The following can be controlled in a vehicle equipped with this system:

- When the manhole cover is opened and closed,
- When the bottom valve is opened and closed,
- When API couplings are opened and closed,
- When the cabinet door is opened and closed,
- Information on when it is opened and closed can be reported from the monitor.
- Make sure that the weight or dimensions of the load do not exceed the technical and legal limits.
- Note that vehicle stability may be affected by the load distribution, the braking distance may be longer and a larger turning radius may be required.
- During loading, consider the laws of the countries you are going to and passing through, as well as the laws.
- Give attention to the maximum axle weight and total weight.
- Comply all national/international laws, rules, and regulations about loading and occupational safety.

7.5. Considerations During Loading – Unloading

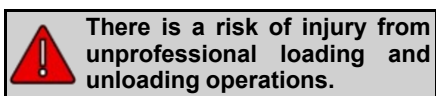

Safety reminder

7.6. Filling

7.6.1. Preparation of Filling

Keep the protective equipment ready, suitable to the material that will be loaded and wear protective clothes. Follow the ADR regulations and safety instructions of material.

Depending on the transported material, clean inside the tank appropriately before new loading. For detailed information see the section of **"Cleaning of Vehicle"** at chapter **"General Information and Safety Instructions"**.

- Never stand on the upper part of the vehicle, if folding handrail is not opened and the vehicle is not secured against unpredictable moving of the vehicle.
- Hand brake of the vehicle should be enabled.
- Vehicle should be on a flat condition.

Before filling process;

- Be sure that you are aware of safety instructions of shipper,
- That all connections are complete and secure.
- That the loaded material is suitable to the material of vehicle and sealing elements.



Residues of material left in the tank may contaminate the material in the next loading and make it unusable. If it is dirty, clean the inside of the tank.

Fuel that is permissible for tanker vehicle can be filled either from top via manholes, or from bottom via API couplings in the armature box.



When loosening or tightening a manlid that is under pressure, the manlid can tear away explosively from the tank and injure you or other people.

- **Never loosen or tighten a manlid when the tanker vehicle is under pressure.**

Filling can be realized in 2 ways.

7.6.2. Filling From Top

1. Draw near the filling station. Stop the vehicle. Engage the tractor handbrake. (Air will not enter the system until the tractor handbrake is applied.)

2. Provide necessary safety on the surroundings before starting the filling process.

3. Perform grounding process with the help of grounding pins (1) on the right and left sides of vehicle. Pool drain valves must be closed before filling and opened after filling. It can be taken with a bucket in case of overflow.

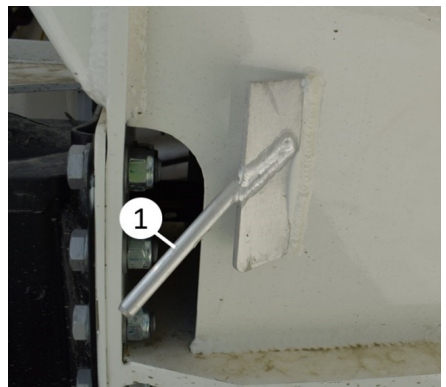

Grounding pin

4. Before climbing to the manhole area by vehicle ladder, open the guardrails, at that time park brakes are activated and the vehicle will be secured against unpredictable moving of the vehicle.

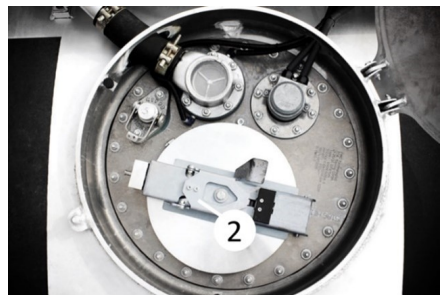

Lever and pin

5. Open the manhole cover via the lever (2) at filling neck (See section “**Components and Use of Upperstructure**”)

6. Insert the hoses in the station, inside the manhole.

7. Vehicle is ready for filling from top.

8. Fill each compartment max. to its NET volume.

9. Avoid overloading. On some versions of the vehicle, bottom valves are not opened and discharge is not allowed when the permissible volume during filling is exceeded.

10. Close manhole covers, after each compartment is filled separately or simultaneously from top.



Opened ladder



Folded ladder

11. Close the handrails stepping down from vehicle ladder. (3,4)

12. Remove the grounding lines.

13. Vehicle is ready to drive.



If the grounding pin is not connected, statical load may cause sparks and explosions.

- **Connect the grounding pin while filling and discharging processes.**



During filling process, breathing load or contact with skin or eyes may result in injury.

- **Avoid physical contact with load. Do not breathe the steam that comes out.**
- **Use protective equipment according to the type of load.**
- **If the load causes an injury, contact to material safety document for necessary emergency measures.**



Using tools that result in sparks or statical loading may cause explosion.

- **Smoking, using cellular phones or cameras, approaching with fire or open flames are forbidden during filling process.**
- **Do not use spark producing tools during filling or preparation period.**
- **Always connect grounding pins during filling or discharging of tank.**
- **Do not use inappropriate mobile phone - camera in operation.**



Emergency buttons are push type. When pressed, it stops filling or discharging in an emergency.

7.6.3. Filling From Bottom

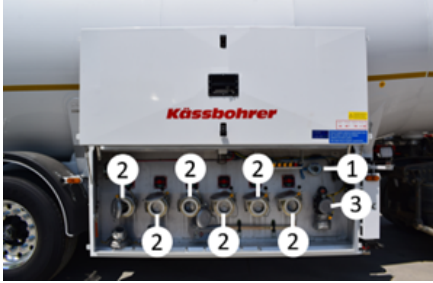

Armature box

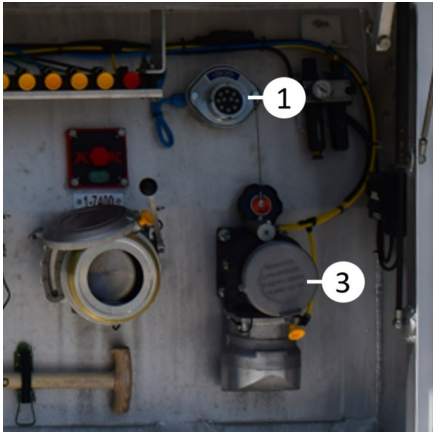

Overfill socket, gas return

1. Draw near the filling station. Stop the vehicle. Engage the tractor handbrake.
2. Provide necessary safety on the surroundings before starting the filling process.
3. Perform grounding process with the help of grounding pins on the right and left sides of vehicle. In addition, you can also use the grounding elements located on the station side and inside the box.
4. Open the cover of the armature box. Park brakes are activated at that moment and vehicle is secured against unpredictable movements (to open the

armature cover, see section “**Components and Use of Upperstructure**”).

5. Perform electrical connection to “J” channeled electrical socket (1) from station for over filling protection and grounding. By this way, protection against over filling can be realized.

6. Dismantle the API couplings dust covers (2) in filling compartments and perform the connection of filling couplings in station (to dismantle covers, see section “**Components and Use of Upperstructure**”).

7. In order to recover fuel steam during filling, connect existing steam adapter (3) on vehicle to related installation on the station. Make sure that the opposite part is pressed against the interlock switch on the steam adapter.



Pneumatic control block

8. Open the valves of related compartment or compartments, using pneumatic control block that controls pneumatic bottom valves and get it ready for filling. If the pneumatic installation pressure is lower than 3 bars, the bottom valves do not function. Operation pressure of bottom valves is between 3-6 bars . Check these values before entering the filling station. Top up if there is missing air.

9. Enter the related fuel and amount to filling station. Vehicle is ready for filling from bottom.

10. In case a problem during filling, bottom valves are closed with the help of emergency buttons (4) present both on left and right side of the vehicle and filling process can be stopped.

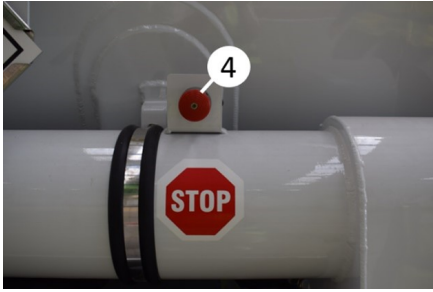

Emergency button

11. After completion of filling process, dis-mantle the connection between station filling couplings and vehicle filling/ discharging coupling, close API coupling metal covers (for installation of covers, see section “**Components and Use of Upperstructure**”).

12. Close the bottom valves with the help of pneumatic control block.

13. Dismantle over filling electrical sock- et connection.

14. Dismantle steam adapter connec- tion, if exists.

15. Close the cover of the armature box.

16. Vehicle is ready to drive.

7.7. Discharge

1. Draw near the discharge station and stop the vehicle.

2. Provide necessary safety on the sur- roundings before starting the discharge process.

3. Perform grounding process with the help of grounding pins on the right and left sides of vehicle. In addition, you can also use the grounding elements located on the station side and inside the box.

4. Open the cover of the armature box. Park brakes are activated at that moment and vehicle is secured against un- predictable movements (to open the armature cover, see section “**Compo- nents and Use of Upperstructure**”).

5. Dismantle the API couplings dust covers (1) in discharge compartments and perform the hose connection of couplings in station (2) (to dismantle covers, see section “**Components and Use of Upperstructure**”).



API coupling cover

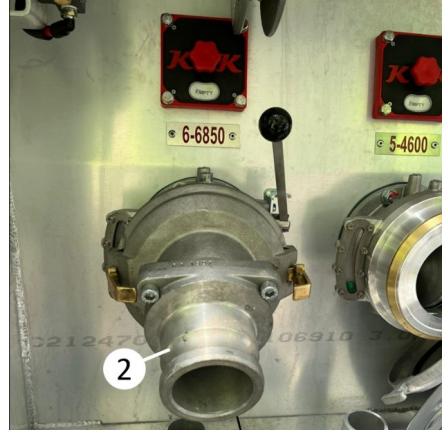

Coupling

6. In order to recover the fuel steam dur- ing discharge, if any, you can perform steam recovery by connecting the rele- vant installation at the station to the steam adapter on the vehicle.

7. Open the valves of related compart- ment or compartments, using pneumatic control block that controls pneumatic

bottom valves and get it ready for discharge.

8. Vehicle is ready for discharge.

9. In case a problem during discharge, bottom valves are closed with the help of emergency buttons (3) present both on left and right side of the vehicle and discharge process can be stopped.



Emergency button

10. Close the bottom valves with the help of pneumatic control block.

11. After completion of discharge process, dismantle the connection between station discharge couplings and vehicle filling/discharging couplings, close API couplings metal covers.

12. Dismantle steam adapter connection, if exists.

13. Close the cover of the armature box.

14. Vehicle is ready to drive.

7.7.1. Discharging With Pump

May be available on some vehicle models.

Tractor must have:

1. PTO (Power take off shaft)
2. Oil tank
3. Hydraulic pump connected to PTO
4. Hydraulic connection hoses with one male and one female inlet for pressure and return connection of the hydraulic line.

Discharge

- 1. Draw near the discharge station and stop the vehicle.
- 2. Fix the vehicle with wheel chokes.
- 3. Perform grounding process with the help of grounding pins on the right and left sides of vehicle.
- 4. Open the cover of the armature box.
- 5. Make the hydraulic plumbing connections. (Quick coupling connections)
- 6. Dismantle the API coupling covers in the compartments to be discharged, and connect the compartment to be discharged and the ball valve at the pump inlet with the discharge hose. It is realized by connecting the ball valve at the pump outlet to the filling couplings at the station.
- 7. Open the API coupling lever of the connected compartment to be discharged.
- 8. Open the ball valves at the pump inlet and outlet.
- 9. Open the By-Pass line. In case of mechanical, By-Pass line should be opened. In pneumatic versions, it will automatically open itself.
- 10. Open the valves of related compartment or compartments, using pneumatic control block that controls pneumatic bottom valves and get it ready for discharge.
- 11. Engage the PTO.
- 12. In order to recover the fuel steam during discharge, if any, you can perform steam recovery by connecting the relevant installation at the station to the steam adapter on the vehicle.
- 13. Vehicle is ready for discharge

- 14. Open the hydraulic control lever and start the discharge.
- 15. After the discharge starts, the By-Pass valve should be closed slowly and the discharge rate should be adjusted.
- 16. In case a problem during discharge, bottom valves are closed with the help of emergency buttons present both on left and right side of the vehicle and discharge process can be stopped.
- 17. After the discharging process is completed,
 - Close the bottom valves using the pneumatic control block.
 - Close the pump inlet valve,
 - Close the hydraulic control lever,
 - Close the pump outlet valve,
 - Close the metal covers of the API coupling by removing the connection between the station discharge couplings and the vehicle filling - discharge couplings.
- 18. Disconnect the electrical socket connection.
- 19. Disconnect the steam adapter connection, if any.
- 20. Turn off the PTO.
- 21. Disconnect the hydraulic line connections. (Quick couplings)
- 22. Close the armature cabinet door.
- 23. Remove the tire chocks.
- 24. The vehicle is ready for action.



For using instructions and warranty terms of the pump, see the manufacturer's user's manual.

7.7.2. Points to Check Before Starting the Pump

- Whether the pump lines are supported (connections)
- Whether the pump shaft rotates freely
- Whether the motor direction is in accordance with the suction - pumping speed direction.
- Whether the By-Pass system is correct or not.
- It should be checked whether the valves in the suction and pumping lines are open.
- Before starting the pump, check whether the lubrication is done sufficiently.
- Before starting the pump, put 0.5 – 2.5 liters (depending on the size of the pump) no. 50 engine oil into the pump.
- After the final checks, the pump should be started and if the liquid still does not come after a certain period of time, the pump should be stopped.



In order to prevent your pump from malfunctioning and leaving you in trouble, maintain your pump periodically. These periods are;

A- The daily working hours of your pump,



For using instructions and warranty terms of the pump, see the manufacturer's user's manual.

7.7.3. Conditions for Getting the Most Benefit from the Pump and Using it in the Safest Way

- If there is an air leak in the suction line, do not force the pump and prevent this leak.
- If you are not using By-Pass, make sure that there is no closed valve in the pressure line.
- Keep the number of fittings in your installation to a minimum.
- Do not run the pump dry.
- Do not load the pump suddenly in liquids with high viscosity.
- Clean the filter at certain times that you can determine according to the cleanliness and pollution of your liquid.
- After using your pump for a while, check the frequency of the bolts.

If Not Sufficient Flow Is Received From The Pump:

- 1. Check the direction of rotation, it may be reversed.
- 2. The suction pipe may not be fully inserted into the liquid. Ensure full dive.
- 3. There may be a closed valve in the suction and discharge lines of the system.
- 4. Pump suction line can breathe. Prevent leaks.
- 5. Your filter may be dirty or clogged. Clean the filter.
- 6. The filter may not be suitable for the liquid.

- 7. If you are using a valve in the suction line, the valve may be closed.
- 8. By-Pass may be set under the required pressure in the system or dirt may have entered between the By-Pass valve. Clean the By-Pass and make sure that the valve is fully seated.
- 9. In pumps with soft packing, the packing may be worn. Replace the packing.
- 10. The suction line is either too thin or too long or contains many fittings.
- 11. If the pump has been in service for a long time, the working parts may be worn. Replace these parts.
- 12. The pump speed may be selected low according to the pump and the liquid.
- 13. There may be air in the system. Evacuate the air from the system.
- 14. Suction height may be too high.

If the pump runs but the suction weakens afterwards:

- 1. The suction pipe may not have penetrated into the liquid sufficiently.
- 2. There is evaporation in the suction line, reduce the suction height.
- 3. There is air in the system.

If the Pump Draws Too Much Power:

- 1. Liquid is more viscous than pump.
- 2. There may be a blockage in the discharge line.
- 3. The soft packing may be too tight. Loosen the packing.
- 4. The pump shaft is bent. Change the shaft.

- 5. Review the settings of the pump and motor.

Note: The type of oil we recommend to use; ISO VG32 HLP (VIS.AT40C°)

TECHNICAL SPECIFICATIONS:

ISO CLASS: 32

DENSITY 15 °C, GR/ML: 0,856

VISCOSITY 40 °C, CST (centistokes) : 32

VISCOSITY 100 °C, CST (centistokes) : 5,4

VISCOSITY INDEX: 109

FLASH POINT: °C: 224

POURING POINT: °C : - 48

If there is a problem in filling-discharging, check the following steps:

- 1. Emergency buttons should not be pressed. If it is, please remove it. Press in an emergency.
- 2. The handbrake of the tractor must be applied. Otherwise, air will not enter the system.
- 3. You should see 3 bars or more from the conditioner inside the armature cabinet. The system will not work if it is below 3 bars.
- 4. If there is still a problem with the system, separate the trailer from the tractor. Remove the yellow (1) and red (2) couplings. Let black (3) be drawn towards you from the valves on the left side of the vehicle. Keep the red button pressed. (4)



Yellow and red couplings

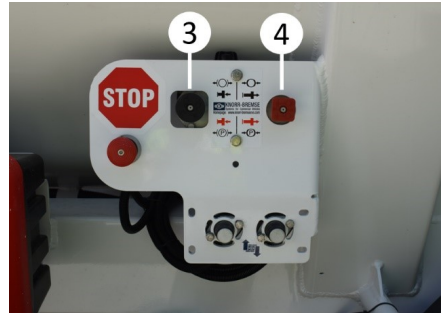

Brake control elements

- 5. Turn on the main button (K) before the control block. (5) Then open the number of the relevant compartment. You can fill/discharge.



Main button

8. INSPECTION AND MAINTENANCE

8.1. Safety Instructions

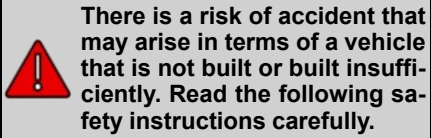

- Obey all traffic laws, rules and regulations.
- Comply with all environmental regulations. When removing operation, maintenance and cleaning residues, act according to these rules.
- Maintenance operations should be carried out by authorized services.
- In addition, ensure that the equipment used in the vehicle such as axles, landing gears, pump, counter, hose reel are checked and serviced at the intervals specified in the manufacturer's user manual.

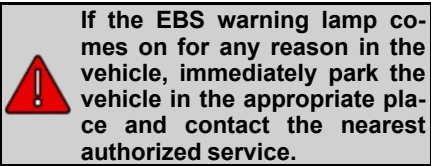
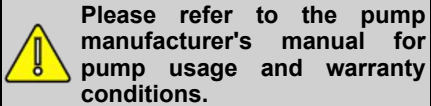

8.2. Main Principles

The purpose of the maintenance operations on the vehicle is to provide the following.

- Always maintain the operating status of the semi-trailer,
- To prevent unexpected breakdowns and to extend the life of the vehicle,
- To prevent permanent damage to the semi-trailer,

- To ensure that the semi-trailer maintains its value,
- Reducing repair time for unavoidable repairs.

8.3. Checks to Be Performed Of The Time of the Delivery

- Check that the electrical system and connections and all lighting elements, brake and signal lamps are working properly.
- Check that the documents of the vehicle are in the vehicle.
- Grease the wheel plate and king pin.
- Check the tightness of the wheel nuts.
- Check that the landing gear works in both speed ranges.

8.4. Manhole Covers

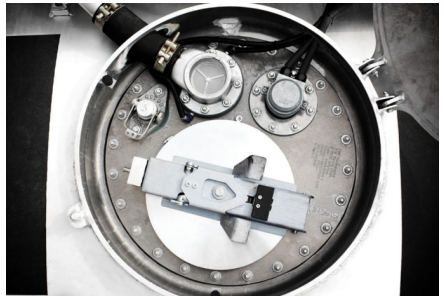

Manhole

Leak tightness

Small amounts of hissing air emerging while loading and unloading do not usually constitute a problem. However, none of the load should come out with the air.

Seals

The seals can only be checked when the silo vehicle is depressurized. The manhole cover must be open.

Seals;

- Must be in visibly good condition.
- It must be clean.

Replace damaged seals as soon as possible.

8.5. Periodic Maintenance and Controls

For periodic maintenance and checks, see the warranty and maintenance manual.



For the validity of the warranty period, the first maintenance and annual periodic maintenance must be done at authorized services.

8.6. Important Warning!

- Check the lining thickness periodically. If the lining thickness has fallen below half, more frequent checks must be made and the lining must be changed by applying to the authorized service before the lining is finished. In the same way, the wear checks of the brake discs should be made periodically, and if there are excessive deformation and cracks on the disc surfaces, an authorized service should be immediately applied. In addition, the caliper piston and bellows should be visually checked and the operability should be checked by moving the caliper back and forth.
- For the necessary controls and periodic maintenance of the axles in your vehicle, the points in the service and maintenance instructions booklet given by the axle manufacturer with your vehicle should be applied meticulously and in accordance with the periods given in the same booklet. Failure to carry out such maintenance may affect the service life of the axles of the vehicle and may cause the axles to be out of warranty in case of a possible malfunction.

- The healthy operation of the brake system of the semi-trailer depends on the use of the semi-trailer with the same system and/or compatible tractor. For this reason, it is obligatory for the buyer to make the brake adjustment adjustment at the authorized service of the tractor company together with the tractor to which these semi-trailers / semi-trailers will be matched. In case the semi-trailer is paired and used with the tractor / tractors for which the adjustment of the semi-trailer is not made or cannot be made, the malfunctions and damages that may occur in the brake system or the tractor and the semi-trailer are outside the responsibility of our company, and all responsibility in this regard belongs to the buyer.

8.7. Trouble Shooting

8.7.1. Safety Instructions





Risk of accident due to unprofessional troubleshooting.

Read the following safety regulations.

- Comply with all laws, rules, and regulations to prevent accidents.
- Comply with all environmental protection rules. Dispose of process residues, cleaning aids and other residues in accordance with these rules.
- Troubleshooting work should only be carried out by trained personnel.
- Before troubleshooting, park the vehicle on a firm, level and level surface and make sure it is secured against slipping / tipping over.
- Upon completion of the repair, ensure that all protective devices are correctly placed and secured.

- Only use original spare parts!

 In cold weather, ice may form on the floor. Care should be taken while walking.

 For the repair process of the malfunctioning product, follow the instructions given by the manufacturer of that product in the user manual.

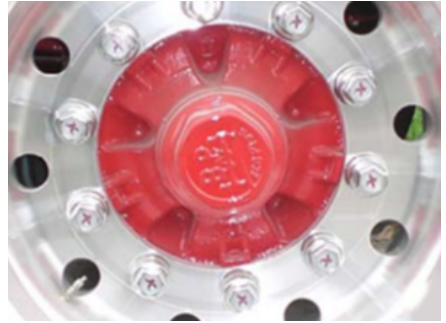

Wheel Nuts covers

8.7.2. Spare Tire Replacement

 Wheel nuts that are not tightened properly will loosen. This may cause accidents. Tighten the wheel nuts to the specified torque. You can find the torque values in the manufacturer's manual for "Axles". Check the tightness of the nuts immediately after each tire change.

 Take the damaged wheel off the axle, grab the wheel only by the right and left cheeks, never remove it by holding the top or bottom.

Remove the spare tire from its holder. See spare tire holder section for detailed information.

Removing the tire:

- Park the vehicle in a safe place away from traffic.
- Secure the vehicle with wheel chocks against rolling away or tipping over.
- Apply the spring-loaded parking brake, see "Construction Components and Use of Semi-trailer" for detailed information.

 Lock the tractor securely to prevent spontaneous or unintentional movement of the tractor during tire changing.

- Loosen the wheel nuts only one turn.
- Place the lever jack under the axle as close as possible to the tire to be replaced.
- Raise the axle until the tire to be replaced is no longer in contact with the ground. Remove the wheel nuts.

Fitting The Spare Tire:

- Position the spare tire as close to the wheel hub as possible.
- Lightly oil the nut threads when refitting the wheel.
- Insert a bar directly under the tire and push the wheel bolts into the holes of the rim by leveraging. Be careful not to damage the threads of the studs during this process.
- Tighten the wheel nuts as much as possible by hand tightening.
- Tighten the nuts with the wrench in the order shown in the picture.
- Lower the jack and tighten the wheel nuts in the same sequence with the required torque. Repeat this process after the first 80 km and daily for the first week.

Check the wheel nuts for torque every week.



Possible problems that may arise in the future can be prevented by checking all the bolt holes on the rims against ovalization at regular intervals.

Excessive tightening of the nuts of the wheel bolts will cause radial deformations around the hole, and if not tightened enough, it will cause deformations around the hole.



Bolt holes in rims



Follow all maintenance instructions, including those of the manufacturer of the vehicle parts, and always keep these instructions in your vehicle.



The manufacturer cannot be held responsible for wear and defects caused by excessive force, or for malfunctions caused by unauthorized modifications. Irregularities or functional faults in the braking system must be rectified immediately! Only use vehicles whose brake system is functioning properly.



There is a risk of burns if hot brake parts are touched.



Kässbohrer Sales GmbH

Ulm | Im Katzenwinkel 5, 88480 Achstetten, Deutschland | T +49 (0) 7392 96797-0 | F +49 (0) 7392 96797-67

Goch | Siemensstraße 74, 47574 Deutschland | T +49 (0) 2823 9721-0 | F +49 (0) 2823 9721-21 | E info@kaessbohrer.com | www.kaessbohrer.com
info@kaessbohrer.com | spareparts@kaessbohrer.com | aftersales@kaessbohrer.com

Kässbohrer

Ingenuity, since 1893