



USER MANUAL
TIPPER SERIES



Index

1. GENERAL INFORMATION AND SAFETY INSTRUCTIONS	
1.1. About the User Manual	7
1.2. Meanings of Symbols Used in User Manual.....	7
1.3. Personal Protective Equipments.....	8
1.4. Terms of Use and Safety Information	9
2. MAIN INFORMATIONS	
2.1. Vehicle Identification Plate	10
2.2. Brake Data Plate.....	10
2.3. VIN (Chassis) Numbers	10
2.4. Warranty and Responsibility	10
3. TRAILER RUNNING GEAR AND USAGE INSTRUCTIONS	
3.1. Brake System	12
3.1.1. Air Couplings.....	12
3.1.2. Compressed Air Tanks	15
3.1.3. EBS Socket.....	15
3.1.4. Roll Stability Support (RSS).....	16
3.1.5. PREV (Park Release Emergency Valve).....	17
3.1.6. Brake Chambers	18
3.2. Suspension System.....	19
3.2.1. Manuel Control	19
3.2.2. Auto Reset.....	20
3.2.3. Electronic Controlled Air Suspension (ECAS).....	20
3.2.4. Manometer (Axle Load Indicator)	20
3.2.5. Smartboard (Info Center)	21
3.3. Electrical System.....	21
3.3.1. 15 Pin Socket.....	21
3.3.2. 2x7 Pin Socket.....	22
3.3.3. Light System	23
3.4. King Pin	24
3.5. Landing Gear.....	25
3.5.1. Front Landing Gear's Working Principle.....	25
3.5.2. Aluminum Landing Gear	26
3.6. Side Protection Equipment (Side Underrun Protection)	27
3.7. Semi-Trailer Axle System.....	28
3.7.1. Self-Steering Axles	28
3.7.2. Axle Lifting.....	29

- 3.7.3. Hubodometer.....30
- 3.8. Tires.....30
- 3.9. Spare Wheel Holder31
 - 3.9.1. Crane Type Spare Wheel Holder.....32
 - 3.9.2. Swedish Type Spare Wheel Holder.....32
- 3.10. Mudguards.....33
- 3.11. Wheel Chock.....33
 - 3.11.1. Pin Type Wheel Chock Holder.....34
- 3.12. Boxes and Storage Units34
 - 3.12.1. Plastic Toolbox.....34
 - 3.12.2. Stainless Toolbox34
 - 3.12.3. Fire Extinguisher Cabinet35
 - 3.12.4. Water Tank35
 - 3.12.5. Document Box36
- 3.13. Bumper.....36
 - 3.13.1. Lifiable Bumper36
 - 3.13.2. Spring-Loaded Bumper.....37
 - 3.13.3. Automatic Bumper.....37
- 3.14. Ladders.....38
 - 3.14.1. Access Ladder38
 - 3.14.2. External Ladder.....38

4. UPPERSTRUCTURE COMPONENTS AND USE

- 4.1. Overview of the trailers upper structure components40
- 4.2. Body40
 - 4.2.1. Body Impermeability40
- 4.3. Front Panel40
- 4.4. Rear Panel40
 - 4.4.1. Tightening Locks.....41
 - 4.4.2. Mechanical Rear Door41
 - 4.4.3. Hydromechanical Rear Door.....41
 - 4.4.4. Combi (Combined) Rear Door.....44
 - 4.4.5. Grain Door46
 - 4.4.6. Double Hinge47
- 4.5. Grain Bag48
- 4.6. Walking Platform and Access Ladder48
- 4.7. Lifting and Lowering the Tub48
 - 4.7.1. Lifting the Tub with Joystick48
 - 4.7.2. Lowering the Tub with Joystick.....49
 - 4.7.3. Lifting the Tub with Switch50

4.7.4.	Lowering the Tub with Switch.....	50
4.7.5.	Lifting the Tub with Remote Control Device	51
4.7.6.	Lowering the Tub with Remote Control Device.....	51
4.7.7.	Lifting the Tub with Remote Control Device	52
4.7.8.	Lowering the Tub with Remote Control Device.....	53
4.8.	Tarpaulin	53
4.8.1.	Rolling Aluminum Pipe	53
4.8.2.	Automatic Tarpaulin.....	55
4.8.3.	Mechanical Tarpaulin.....	56
4.9.	Hydraulic System.....	58
4.9.1.	Tipping Cylinder Connection.....	58
4.10.	Hydraulic Piston.....	58
4.10.1.	Hydraulic System Connection Points.....	58
4.10.2.	Pump – PTO Connection	58
4.10.3.	Use of Telescopic Cylinder	60
5.	TRANSPORTATION PROCESS	
5.1.	Pre-Driving Checks.....	63
5.2.	Semi-Trailer and Tractor Coupling.....	63
5.3.	Loading – Unloading Operations	64
5.4.	Cautions During the Parking and Stopping.....	65
5.5.	Loading	65
5.6.	Important Technical Considerations	65
5.6.1.	Fire Extinguisher.....	65
5.6.2.	Wheel Chocks	66
5.6.3.	Treylerde Yapılacak Değişiklikler.....	66
5.6.4.	Air Leakage.....	66
5.6.5.	Considerations For the Environment	66
6.	LOADING AND LOAD SECURITY	
6.1.	Loading – Unloading Operations	68
6.2.	Loading	68
6.3.	Safety Instructions.....	68
6.3.1.	Load Security	69
6.4.	Load Distribution and Load Limits of Tractor Semi-trailer Combination	70
6.5.	Tilt Alert.....	70
7.	INSPECTION AND MAINTENANCE	
7.1.	Safety Instructions.....	71
7.2.	Main Principles	71

7.3.	Checks to Be Performed Of The Time of the Delivery	71
7.4.	Cataphoresis Coating	71
7.5.	Periodic Maintenance and Controls	71
7.6.	Important Warning!	72
7.7.	Trouble Shooting.....	72
7.7.1.	Safety Regulations	72
7.7.2.	Spare Tire Replacement	73
7.7.3.	Activation of the Spring-Loaded Parking Brake Emergency Release Button	74
7.7.4.	Brake System	74

FOREWORD

First of all, thank you for choosing us for your new vehicle investment.

Your vehicle is manufactured with the latest production technologies to the highest quality standards and equipped with the best safety and efficiency features.

You can find detailed information about the accessories, equipment and hardware that might be in your vehicle in this manual. The defined options in this manual can vary according to the vehicle specs.

Important information on how you can use your vehicle is explained in this user manual, please be sure that you review and understand the content. We suggest keeping this user manual available in your vehicle at all times. This information is specified in the product's user manual. We recommend you read this operating manual thoroughly to get the most out of your vehicle.

** Owing to the developments in product research, the manufacturer reserves the right to make any changes in the product, without any prior notice. The publication rights of this documentation belong to the manufacturer.*

1. GENERAL INFORMATION AND SAFETY INSTRUCTIONS

1.1. About the User Manual

The usage and operation information given in this manual is prepared to make sure the vehicle is used in compliance with its purpose and as desired.

The instructions here contain important recommendations to perform your operations safely, completely, and in the most efficient manner. Complying with these instructions, warnings and recommendations will prevent accidents, decrease down-time & repair costs, and make sure you use your vehicle safely, reliably and problem-free.

Please read the operating instructions in this manual carefully and completely. The manufacturer is not liable for the damages and deficiencies caused by the failure to comply with these instructions. The instructions herein must be supported by local laws, rules and regulations. Please comply with these instructions to prevent accidents and protect your surroundings and the environment.

Any usage of transportation that goes beyond the use in accordance with the rules will be considered improper use.

Transportation of the following is not allowed:

- Carrying people and live animals
- Transportations that need to be carried according to special instructions, e.g., dangerous good transportations
- Transportation of unsecured goods
- Transportation of materials that are dangerous due to their properties or that need to be carried with special equipment
- Exceeding technically and legally permissible weights of the axles or king pin load

- Exceeding of the maximum vehicle speed
- Exceeding the permissible length, width and height
- Unapproved parts like tires, accessories, spare parts and etc. by the manufacturer
- The manufacturer shall not accept any responsibility for the problems and faults that occurs that are not in compliance with the purpose of the vehicle's usage. All the risks of this issue belong to the customer.

 **It is necessary to keep the user manual available on the vehicle at all times.**

 **The vehicle can be equipped with a lot of different options. The standard or optional features will be explained in the manual. Some options may not be available for your vehicle**

 **Adhere strictly to the operating instructions when using your vehicle. When problems occur which can lead to dangerous consequences, contact the service centre immediately.**

1.2. Meanings of Symbols Used in User Manual

Several warnings are available in this manual to ensure maximum safety when using your vehicle. Each warning is indicated by a special symbol. These symbols and their meanings are as follows.

 The information specified by this warning symbol is very important for health and human safety. When the given information is ignored, serious damage, injuries and even death may occur.

 This symbol specified in this manual indicates that critical accidents may occur when the instructions do not comply.

 This symbol is used when additional information is required.

 This symbol is used when chemicals and other substances can be disposed of with precautions that will not harm the environment.

1.3. Personal Protective Equipments

Personal protective equipments serves the purpose of preventing injuries and are prevents injuries and are determined by regional regulations depending on the load carried.

People who will work or perform operations on the vehicle must wear proper and appropriate protective clothing.

- Depending on the load to be carried, the eyes, ears, body, and respiratory tract must be protected with the relevant protective equipment.
- As a rule, gloves and work shoes are always used.

 It is obligatory to use appropriate personal protective equipment during the operations.

 Long hair is particularly dangerous when working on the vehicle, regardless of whether it is loose or tied up, and it should be protected properly to avoid tangling.

 Wearing a tie, necklace and/or dangling jewelry when working on the vehicle is strictly prohibited. They may get caught in moving parts or mechanisms and cause injuries and even death.

Protective Gloves

 During the operation, protective gloves must be used. Please make sure you are using the correct type of gloves when you are working with hot parts or chemicals.

 Gloves should fit snugly. Otherwise, there is a risk of them getting caught in moving parts or mechanisms.

Protective Cloth

 While working on the vehicle, appropriate overalls must be worn.

- Overalls should not have pleats, buttons or external pockets and their closure system should be made in such a way that they can be opened as soon as possible in case of an emergency.
- Interior pockets should have fastenings to close them up. Cuffs should be adjusted to fit the wrist.

Protective Helmets



When working around the vehicle, a lightweight helmet approved by an accredited institution should be worn.

Protective Ear Plugs



A hearing protective device (headsets or ear plugs) should always be used around self-propelled vehicles.

Protective Goggles



Protective goggles should be worn during all maintenance operations.

Protective Mask



Appropriate protective masks should be used when working with substances that are dangerous to breathe or in dusty environments.

1.4. Terms of Use and Safety Information

It is necessary to keep the warranty, operating and maintenance manual and other documentation about the vehicle available on the vehicle at all times.

To prevent possible accidents and environmental pollution, follow the operating instructions and binding regulations.

- Pay attention to the safety and warning signs placed on your vehicle.
- Always keep these safety and warning signs completely visible.
- Make sure that the load carrier is secured properly.
- In case of any dangerous condition in the operation of safety, stop your vehicle immediately and inform the authorized people or institutions.
- Do not modify anything on the vehicle without a written manufacturer's approval. Your vehicles guarantee terms do not cover unapproved modifications.
- The spare parts must meet the technical requirements set forth by the manufacturer company. Only the original spare part/parts meet their requirements.

2. MAIN INFORMATIONS

There are vehicle identification stickers on the vehicle.

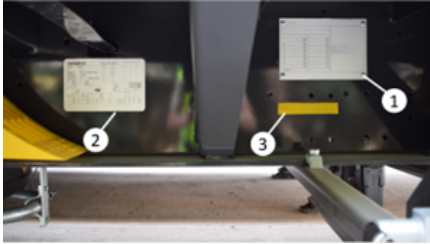

2.1. Vehicle Identification Plate

Vehicle identification plate (1) is located on the right side of the vehicle.

You may find the following information's on this plate;

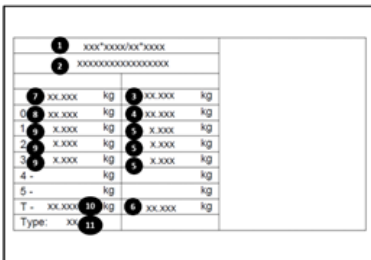

Vehicle Identification Plate

- 1- Type approval number
- 2- VIN number
- 3- Technical total capacity
- 4- Technical king pin capacity
- 5- Technical an axle capacity
- 6- Technical total axle capacity
- 7- Nationally approved total capacity
- 8- Nationally approved king pin capacity
- 9- Nationally approved an axle capacity
- 10- Nationally approved total axle capacity
- 11- Vehicle Type

2.2. Brake Data Plate

There is a brake data plate (2) on the vehicle which is equipped with an EBS system.

You may see this information on this plate;

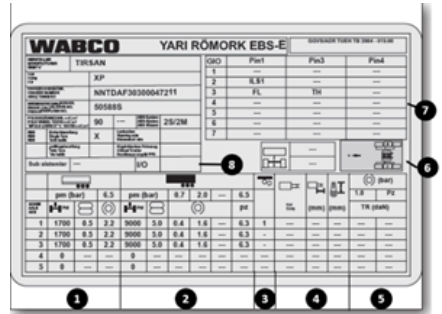

EBS plate

1	Empty vehicle (without load)
2	Loaded vehicle
3	Axle lifting
4	Brake chamber data's
5	References
6	Driving height
7	Pin positions
8	IN/OUT-Connections

2.3. VIN (Chassis) Numbers

The VIN (chassis) number (3) is located on the right side of the vehicle and marked with a different color than the chassis color.

2.4. Warranty and Responsibility

Our trailers, semi-trailers and truck on-board applications are manufactured in compliance with regulations and our

quality standards. It is necessary to perform the maintenance to ensure our products always operate in the most efficient manner in compliance with our latest directives and maintenance programs. The warranty starting date is the date that the vehicle is delivered to the customer.

The performance of maintenance and repair/servicing of the vehicle with the use of original spare parts by authorized service shall assure the client's warranty rights. This warranty is based upon the usage and maintenance conditions described herein and in the warranty book. Thus, it is important to read and understand this operation manual and warranty book.

It is necessary to keep the warranty, always operating and maintenance manual available on the vehicle to allow authorized service performing the servicing to see the warranty conditions and maintenance records. In the repairs made during the warranty period, the authorized service performing the repair will demand this. Purchasing one trailer or semi-trailer is an important investment. For the highest return on your investment, it is necessary to comply with the manufacturer's procedures and recommendations during the operation period of the vehicle. The information provided by the client/driver related to the warranty written in this manual shall be kept within our database.

3. TRAILER RUNNING GEAR AND USAGE INSTRUCTIONS

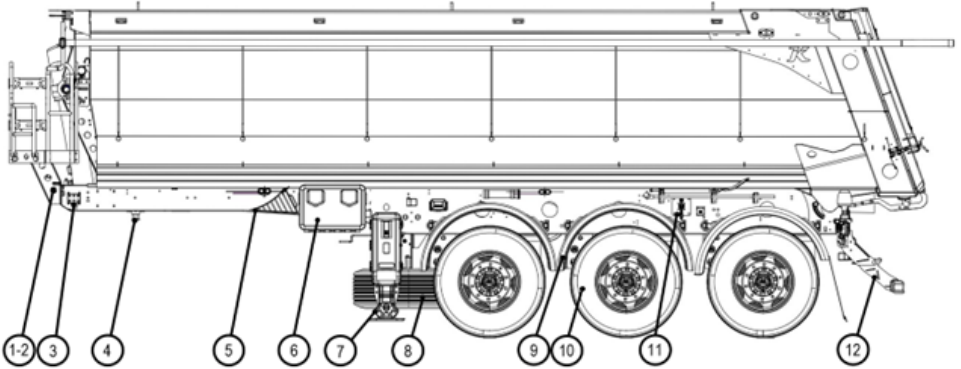

1- 2 Brake/Electric Connections

3 Hydraulic Control Unit

4 King pin

5 Wheel Chocks

6 Toolbox

7 Landing Gears

8 Spare Wheel

9 Mudguards

10 Tires

11 Driving Level Control Valve

12 Bumper

Service Line: Pneumatically air hose which will feeds the brake line.

Supply Line: Pneumatically air hose which will feeds the air tanks and trailer

According to the type of vehicle, your vehicle can be equipped with one or two different types of air couplings.

- Standard Couplings (Palm)
- Duomatic Coupling
- C (UK) Couplings

3.1. Brake System

3.1.1. Air Couplings

The main connection between the truck and trailers is air couplings.

Generally, 3 different types of air couplings are used in the trailers. These 3 types of air couplings have the same function but with different shapes and connections. There are 2 different air supply lines in the system.

Brake Line (Yellow)

Supply Line (Red)



If your vehicle is equipped with 2 different types of couplings, you must use only one type at the same time.



When the couplings are mounting/demounting, the parking brake of the truck and trailer must be engaged.



If the brake parameters are modified, your vehicle's brake calculation might be non-suitable for regulations. Only authorized services must service to the EBS modulator.



Only authorized services and personnel should make service operations for the brake system.

There might be test points on the chassis or above the air couplings. When you remove the test points rubber protection parts and push the points you can check the air pressure on the brake lines.



Test point



Palm coupling with a test point

3.1.1.1. Mounting of Standard (Palm) Couplings

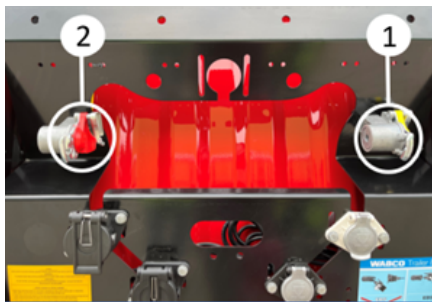

Couplings

- Slightly slide plastic covers to the upper side. Slide plastic covers to upper side
- Be sure that sealing surfaces are clean and durable. If necessary, clean/change the air coupling.
- The coupling which comes from the truck should be pushed slightly from the upper side to the lower side and connect the coupling. Be sure that couplings are matched correctly.
- First mount service line yellow (1).
- Mount supply line red (2).

3.1.1.2. Demounting of Standard (Palm) Couplings

- The coupling which comes from the truck should be pushed slightly from the lower side to the upper side and demount the coupling.

- First demount the supply line red (2).
- Demount the service line yellow (1).
- Slightly slide plastic covers to the lower side and close the plastic covers.

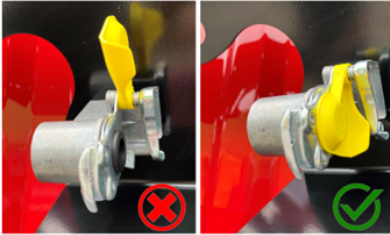

Closing the coupling

 **Driving with a non-suitable air connection is dangerous and forbidden**

 **Using damaged air supply parts can cause serious hazards. Torn or damaged compressed air connectors reduce the vehicle's braking performance.**

3.1.1.3. Mounting of C (UK) Couplings

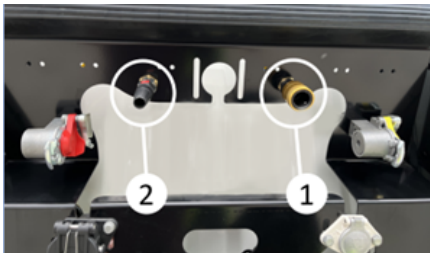

Mounting the C (UK) Couplings

- Be sure that sealing surfaces are clean and durable. If necessary, clean/change the air coupling.
- First mount service line yellow (1).
- Mount supply line red (2).

- Be sure that couplings are matched correctly.

3.1.1.4. Demounting of C (UK) Couplings

- Push the latch from front to back side on the C couplings and remove.
- First demount the supply line red (2).
- Demount the service line yellow (1).

 **The coupling filters have to be clean regularly.**

3.1.1.5. Mounting of Duomatic Coupling



Duomatic Coupling Connection

- Be sure that sealing surfaces are clean and durable. If necessary, clean/change the air coupling.
- Push the arm and mount the coupling (1).

 **The coupling filters must be clean regularly.**

3.1.1.6. Demounting of Duomatic Coupling

- Push the arm and mount the coupling (1).
- Pull back the arm slightly and close the coupling cover.

3.1.2. Compressed Air Tanks

Pressured air can be stored in the air tanks.

The quantities and capacities of the air tanks can be changed according to your vehicle specifications.

In cold periods of the year or when the air humidity is high, the moisture in the air can be condensed and collected in the compressed air tank.

The tractors are generally fitted with air driers to prevent condensation in compressed air. The tractors are generally fitted with air driers to prevent condensation in compressed air. Even if the air driers system, the humidity in the air can be condensed. The condensed water must be drained out via the drain valve.

The water in the air tanks should be completely drained out. That's why please push the valve on the air tanks.





1. Compressed Air Tanks

2. Drain valve

 The water in the compressed air tank can cause corrosion problems and affect the functionality of the brake system. The frozen water in the pneumatic lines can cause the failure of the brake system.

 The water in the pneumatic system should be checked more frequently in cold weather or extremely variable outside temperatures.

 When the air tank pressure is lower than 4,5 bars, the EBS warning lamp on the tractor turns on and the driver can see this situation.

 When the pressure in the service line (in the red coupling) is lower than 2,5 bars, the brakes automatically lock.

3.1.3. EBS Socket

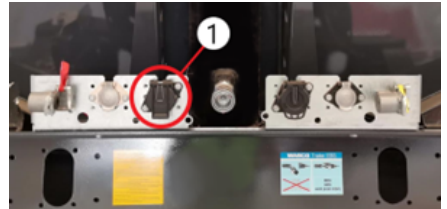

EBS socket

Our trailers and semi-trailers are equipped with an EBS system.

EBS is an electronically controlled brake system, that is fitted with automatic load sensing braking pressure regulation (ALB) and automatic anti-skid systems (ABS/ABV).

To activate the EBS system, your truck and trailer must be equipped with an EBS system. Please mount the EBS cable that will come from the truck to the EBS socket on the trailer.

- Driving with a non-connected EBS connection is illegal.

- Drive only with an approved and well-operating EBS plug connection in accordance with regulations.
- EBS connection must be made between the truck and trailer.
- When the EBS socket mounted and truck engine is activated, you will hear the noise. Please listen and check carefully.
- A system control is performed two seconds after the trailer EBS is switched on; in the meantime, the magnets may be opened and closed audibly for a short time. When plugging the EBS connector, if you cannot hear the system control, a power supply problem exists between the tractor and EBS.

When the truck engine is activated and during the travel, the EBS system will be checked automatically. If the truck screen is suitable/adjusted, the EBS failures will be shown with the EBS mistake lamp.

The EBS mistake lamp on the truck screen will be turned on when the ignition key is activated. If there is no failure on the EBS system, the lamp will be turned off in appr. 2 seconds.

After 7 km/hours speed, If there is a failure on the EBS system (Sensor mistake and etc.) EBS lamps will be flashed.

If the EBS lamp is activated, please contact with authorized services immediately.

 **The trailers equipped with a Trailer EBS E braking system may only be used with tractors with.**

- ISO 7638-1996 connectors (ABS + CAN) or ISO 7638, 7 pin with CAN data line (EBS Truck)

 **If you drive without EBS connectors or if there is a problem on the EBS system, the brake system will not be worked properly. This situation may cause an accident.**

 **Trailers are equipped with an additional power supply for the EBS system. Thanks to the extra power supply from brake lamps, when the EBS connector is damaged, an extra safety function will be activated. The EBS system will be fed from brake lamps and ALB (automatic load sensing braking pressure) and ABV (anti-skid system) functions will be activated.**

3.1.4. Roll Stability Support (RSS)

Rollover stability support (RSS) is integrated into the trailer modulator. The vehicle's electronic control unit analyzes wheel speed, load information and transverse acceleration data to detect the likelihood of vehicle roll-over before the driver realizes there is a risk and automatically applies the brakes. But don't forget that this system cannot cancel the laws of physics.

When the roll-over risk is detected, the EBS system makes automatically brakes and tries the reduce the roll-over risk. After risk, the RSS function will be shut down automatically.



The RSS optimizes driving characteristics and in emergencies may help to prevent accidents. But cannot completely guarantee.



When you are driving the trailers, the red button must be pushed position and the black button has to be pulled position.

3.1.5. PREV (Park Release Emergency Valve)



PREV Buttons

Generally, brake control systems will be located on the driver's side. It may be different on your vehicle according to the vehicle's construction.



PREV Buttons

Black button (1):Service brake button.

Red button (2):Park brake button

3.1.5.1. Service Brake



Service brake

Thanks to the service brake, the trailer can be made maneuvers without air connections. The black button can be used only without air connections on the trailer.

When you push the black button, the service brake will be disabled. When you pull the black button, the service brake will be activated.



If the service brake is used a lot of times, without an air connection, air pressure in the system and braking power may reduce.

When the air connections are de-mounted, the service brake will be automatically activated. When the air connections are mounted, the service brake will be automatically disabled.



The service brake is not suitable for braking of the semi-trailer permanently. During longer waiting periods, the semi-trailer must be secured with a spring-loaded park brake and with wheel chocks.

3.1.5.2. Spring Loaded Park Brake

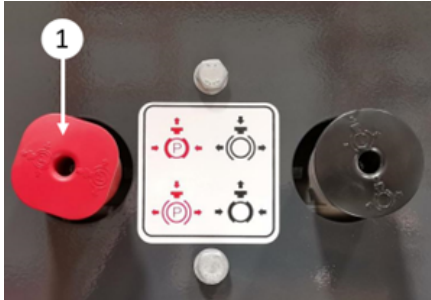

Spring loaded park brake

Spring loaded park brake control button is used for longer parks of semi-trailers with or without tractor on plain or inclined lands.

When the red button is pulled, spring loaded park brake will be activated. When the operator pushes the red button, spring loaded park brake is deactivated.



This brake will not be deactivated automatically. Before driving, the operator must deactivate the brake.

3.1.6. Brake Chambers

Your vehicle may be equipped with disc or drum brake axles according to your choice. For both brake types, the brake chambers are going to use for braking. The brake chambers will be chosen according to axles type and loading capacity. The maintenance, modification or repair operations must be performed by authorized services.

3.1.6.1. Manually Deactivation of Parking Brake Spring

The Parking brake spring may be deactivated manually in emergency situations.

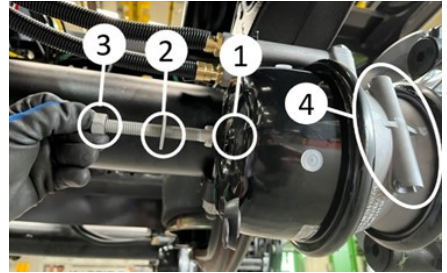

Deactivation of brake chambers

1. Boreholes
2. Release rod
3. Nut
4. Slot of the release rod

- Remove the release rod (2) from the slot (4).
- Insert the release rod (2) to boreholes (1) and screw till the rod (2) will be fitted completely.
- Completely screw in the nut (3) to the release rod (2).

The brake chambers will be deactivated after this operation. In this case, the brake chamber only works on the service brakes. Even if the trailer air tube pressure drops below 2.5 Bar, the spring brake will not be activated due to this operation.



On some brake chambers used in vehicles, the emergency release screw is located in its socket (1) behind the brake chamber, not in its socket (4) next to it. In order to disable the springs, it is allowed to come out by simply turning it with the appropriate key.



This operation should only be used until the trailer is serviced.



Before this operation, the vehicle must be fixed securely with wheel chocks. Serious injuries may occur.

- Close the plastic cover on the brake chamber.

Brake chamber will be activated after this operation.



Before this operation, the vehicle must be fixed securely with wheel chocks. Serious injuries may occur.



Don't drive without being sure that all the brake system is working properly after this operation

3.1.6.2. Activation of Brake Chambers

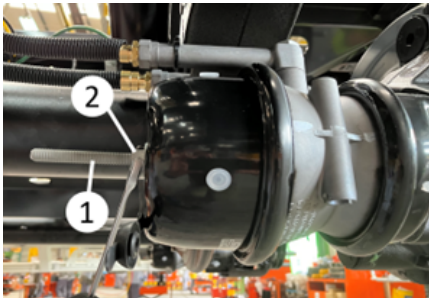

Activation of brake chambers

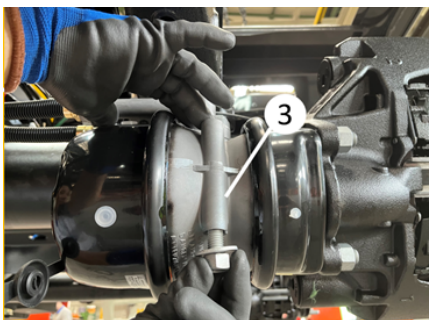

- Remove the nut (1) from release rod (2) with a spanner.
- Remove the release rod (2).
- Screw the release rod into its place on the brake chambers (3)

3.2. Suspension System

Your vehicle is equipped with air suspension system.

3.2.1. Manual Control

You may choose the fifth Wheel height with a control button which is located at the driver side.

When you set the button in position 1, you may use your semi-trailer in a lower fifth wheel height and when you set the button in position 2, you may use your semi-trailer in a higher fifth wheel height.

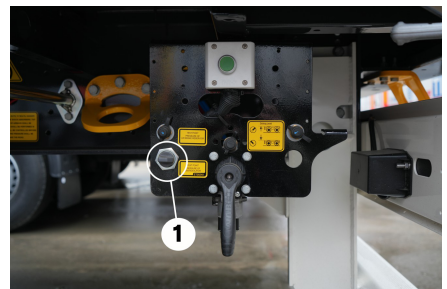

Lower driving height

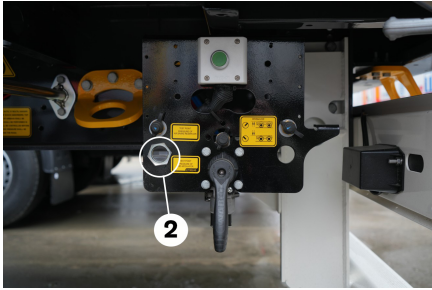

Higher driving height

3.2.2. Auto Reset

The auto reset lever can be controlled by the same method as 3.2.1. manual suspension control lever. When the EBS socket is mounted and driving at a speed defined by the producer, the lever will set the driving height automatically.

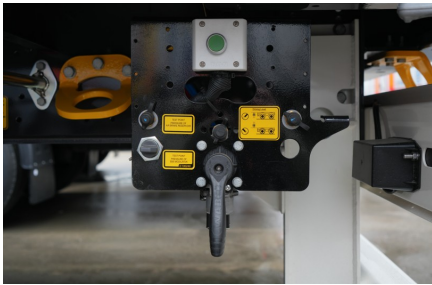

Auto reset

3.2.3. Electronic Controlled Air Suspension (ECAS)

Electronic controller air suspension (ECAS) is an optional solution. This system sets the driving height or defined different heights electronically. When the EBS socket is mounted and driving at a speed defined by the producer, the lever will set the driving height automatically.

You may push the lower or raise button and set the vehicle height.



ECAS control panel

3.2.4. Manometer (Axle Load Indicator)

The manometer which will show the axle estimated axle load may be positioned at the driver side. The manometer will connect to fixed type axles air bags (non-steering and without axle lifting).

When the air bag pressure is bigger, you will see bigger values on the manometers.

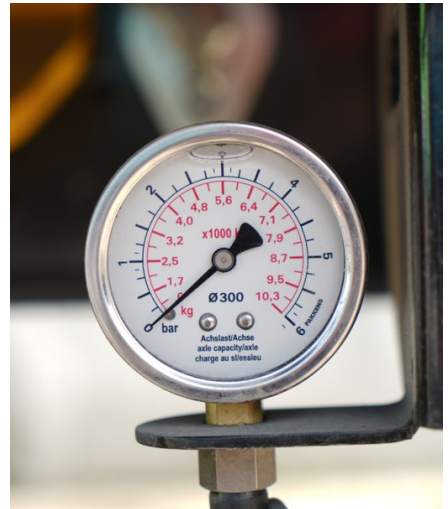

Manometer



This manometer shows only the estimated axle load. It cannot be used as a legal measurement.

3.2.5. Smartboard (Info Center)

Thanks to Smartboard, the operator may see failure codes, axle load etc. information and control the axle lifting system.



Smartboard

If your Smartboard includes the battery, you may use some control even if the truck is not connected.



You may check Smartboard user Manual for the detail information.

3.3. Electrical System

15 pin (1), 2x7 pin (2) or 15 pin+2x7 pin (1+2) electrical sockets are option in our vehicles. Thanks to these sockets, electrical connections between truck and trailer will be made.

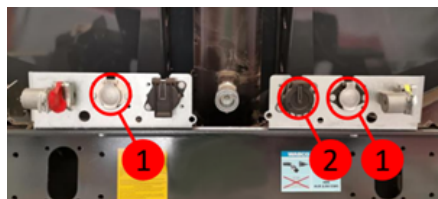

Electrical System



When driving, the electrical sockets between the truck and trailer must be connected.



Please be sure that the truck and trailer are suitable for the norms/standard about electrical systems. Otherwise, electrical problems will occur.

3.3.1. 15 Pin Socket

This system provides electricity for the electrical system on the vehicle like stop lamps, signal lamps etc. 15 pin socket connections are made according to ISO 12098.

Open the protection cover and mount the sockets regularly.

You may find extra information about the pins function in below.

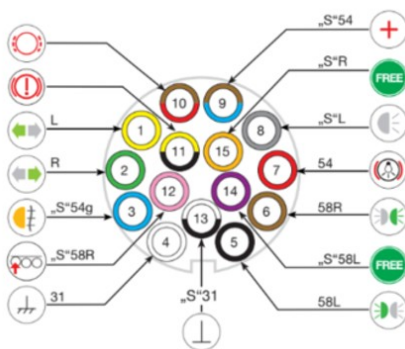

Pin	Meaning
1	Left indicator
2	Right indicator

3	Fog lamp
4	Ground
5	Left taillight
6	Right taillight
7	Brake light
8	Reverse light
9	Supply line
10	Brake Lining Wear
11	Traction Lowering help/Force
12	Axle Lift
13	Chassis Electronics
14	Empty
15	Empty



ISO3731 Soket

Pin	Meaning
1	Ground
2	Empty
3	Reversing lamp
4	Supply line
5	Empty
6	Axle Lift
7	Fog lamps

3.3.2. 2x7 Pin Socket

This system provides electricity for the electrical system on the vehicle like stop lamps, signal lamps etc. 2x7 pin socket pin connections are made suitable for 24S ISO 3731 and 24N ISO 1185 norm.

Open the protection cover and mount the sockets regularly.

You may find extra information about the pins function in below.

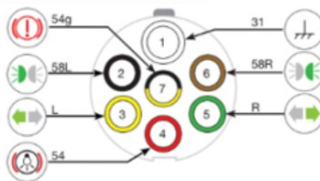

ISO 1185 Soket

Pin	Meaning
1	Ground
2	Left taillight
3	Left indicator
4	Brake light
5	Right indicator
6	Right taillight
7	EBS

Please be careful with the color of the sockets. The black socket is suitable for ISO 1185 and the white socket is suitable for ISO 3731. If the vehicles are suitable for norms, the black socket on the truck will be connected to the black socket on the trailer and the white socket on the truck will be connected to the white socket on the trailer.



3.3.3. Light System

The vehicle is equipped with a light system which is suitable for the regulations.

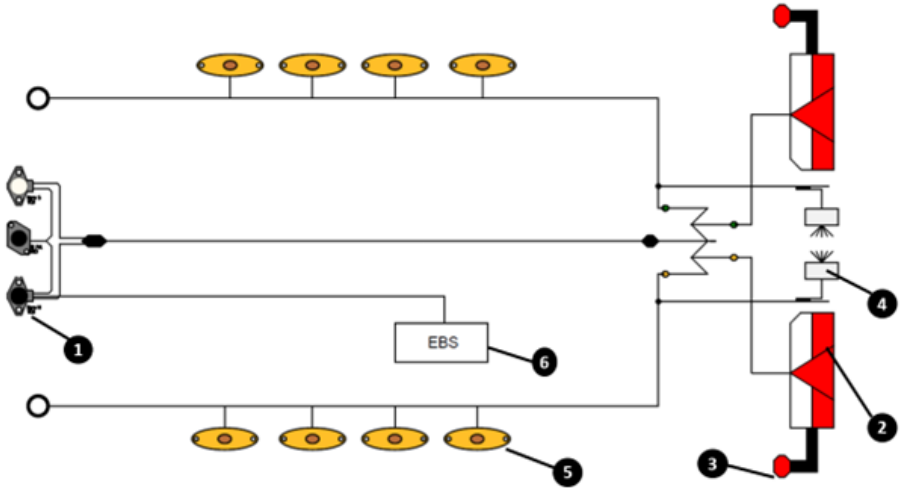



1	Electrical Sockets
2	Stop Lamps
3	End Outline Markers
4	License Plate Lamps

5	Side Position Lamp
6	Modulator

The lamps must be checked regularly. If there is any problem with the electrical system, it must be repaired immediately. In a repair operations, only original and approved sockets or parts must be used.

 If you add or remove any lamps on the vehicle, your vehicle may be non-suitable for regulations.

 Vehicles with LED electrical systems consume very low energy. For this reason, although there is no problem in the system, it may cause the failure lamp to come on in old tractors.

 Repairing operations of the electrical system have to be made by only authorized services. Otherwise, electrical problems may occur or your vehicle may be out of warranty.

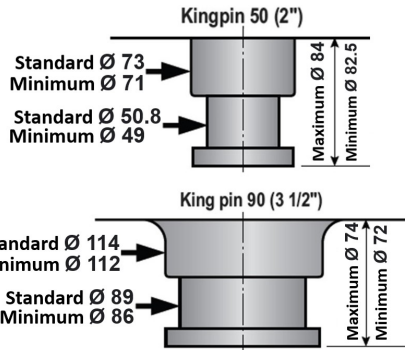

 If you match the truck and trailer with a different diameter king pin, injuries may occur.

The flanged king pin is used on the vehicle. That's why king pin can be replaced easily.

3.4. King Pin

King pin is a shaft which connects truck and railer together. Your vehicle may be equipped with 2" or 3.5" diameter pins. Please check the king pin diameter before connecting the truck.



Kingpin

 If the wearing on the king pin is bigger than 2 mm, the king pin must be replaced.

Your vehicle may be equipped with a double king pin slot. You can remove the bolts around the king pin and mount king

pin to the other slot. Please be careful about the total length of the vehicle according to country regulations and be sure that the total length is suitable for regulations.

3.5. Landing Gear

There is a front landing gear behind the vehicle's gooseneck area so that your vehicle can stop in park without truck.

3.5.1. Front Landing Gear's Working Principle

The landing gear crank handle (1) should be removed from its holder (2) and brought to a perpendicular position to the vehicle.

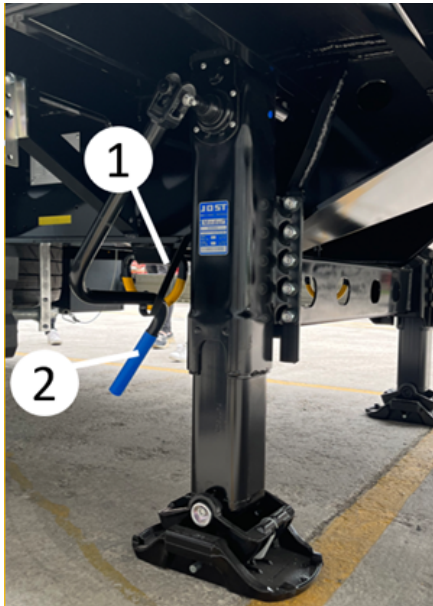

Landing Gear

Low Speed (A): When the crank handle (1) is turned in the fully pressed position, it raises / lowers at low speed.

High Speed (B): It performs high speed lifting / lowering when the lever turned in the fully extended position. The position is used to quickly lower the gear until the foot (plates) touch the ground during the process of separating the semi-trailer from the tractor, or to raise the gear

quickly after the semi-trailer is connected to the tractor.



The landing gear crank handle is usually located on the passenger side of the vehicle.

 In all conditions, secure the semi-trailer against tipping with correctly positioned wheel wedges. If the vehicle is not properly secured, the landing gear or the vehicle may be damaged.

 If the loading / unloading operation is performed while semi-trailer is not paired with the tractor, the front or rear of the vehicle may raise. Serious accident and damaged may occur. For this reason, the semi-trailer must be paired with the tractor during the loading and unloading operations.

 If the tractor leaves from the loaded trailer, be sure that the load is distributed homogeneously in the vehicle. Otherwise, the front or rear section of the vehicle may be raised due to centre of gravity, and accident may occur.

In order to protect the landing gear, be sure that there won't be any lateral movements on your vehicle. For this reason give attention to the following criteria:

- Disconnect the semi-trailer from the tractor only when the landing gear are in the middle (neutral) position.
- If you will park for a long time without the coupled tractor, be sure that air suspensions are lowered and after that adjust the landing gears. Thus, the loading area will be parallel to the ground.



Landing gear view

Optionally, an aluminum landing gear can be supplied.



Before you start to drive operations, make sure that the landing gear is turned off (highest position).

3.5.2. Aluminum Landing Gear

Optionally, your vehicle may have an aluminum landing gear.



Aluminum landing gear



If the loading/ unloading operation is performed while semi-trailer is not paired with the tractor, the front or rear of the vehicle may raise. Serious accident and damaged may occur. For this reason, the semi-trailer must be paired with the tractor during the loading and unloading operations.

Lifting the Landing Gear

- Pull the lever shown in the direction of the arrow.



- Grab the landing gear and lift it up.

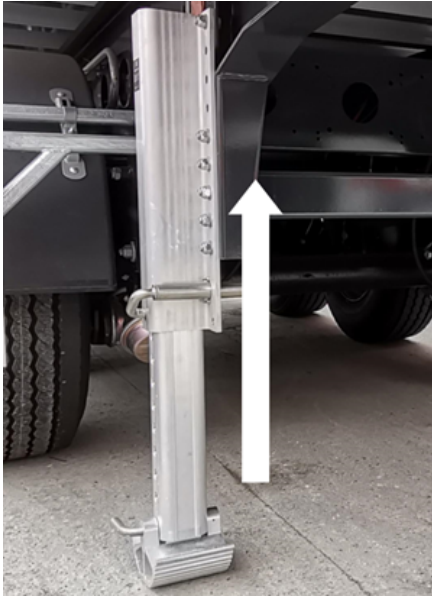

- Insert the pin into the hole.

3.6. Side Protection Equipment (Side Underrun Protection)

The underrun protection must be in the off position during the travel. Some underrun protection equipment can be opened upwards for easier service operations such as accessing the spare wheel holder.



Side Underrun Protection



Opened Position



Closed Position



Travelling with the lifted side underrun protection is dangerous and illegal. In this case, there may be serious injuries, including death, in road accidents that may occur. Before travel, make sure the side underrun protection is lowered and properly secured.

Removing Underrun Protection: Turn the side underrun protection locking pin (shown) on both sides 180° clockwise or counterclockwise. The locking pin will be locked (1). You may open or close the side underrun protection when the pins are positioned like this. After opening the locking pins, lift the side underrun protection upwards. When the side underrun protection is lifted, return the pins to the locking position (2). After making sure that both pins are locked securely, you may release the side underrun protection.



If the underrun protection is not fixed properly, it may fall and cause injury.

Lowering The Underrun Protection:

Lift the underrun protection slightly upwards, unlock the locking pins and lower the side underrun protection carefully. When the underrun protection is lowered, use the locking pins and fix the side underrun protection.

3.7. Semi-Trailer Axle System

Axle with disc or drum type brake mechanism are used in your vehicles.

Semi-trailer axles may only be loaded with the maximum legally permissible axle load indicated on the vehicle identification plate. The user is responsible for use of the trailer in accordance with its purpose and capacity and for its maintenance.

The healthy operation of the brake system of the semi-trailer depends on the usage of the semi-trailer with the same system and/or compatible tractor. For this reason, it is obligatory for the buyer to make the brake adjustment at the authorized service of the tractor company to which these semi-trailer/trailers are to be matched. If you use the unadjusted truck-trailer combination, the producer doesn't take any responsibility for the damage/failure that may occur in the brake system or vehicles. All responsibility belongs to the customer.



For more information about the axles, please check the axle's user manual which was delivered with your vehicle.



If the axles are used other than the conditions specified in the manufacturer's manual or if their maintenance is not made properly, your vehicle may be out of warranty.



If the vehicle is equipped with emergency brake chambers, apply the parking brake after checking the drum temperature. Never use the parking brake when the drums are very hot (the drum may crack).

3.7.1. Self-Steering Axles

Your vehicle may be equipped with a self-steering axle to increase the maneuverability capacity during forwarding driving. This type of axle is usually positioned at the rear axle of the vehicle and has a locking mechanism.



The turning radius of the vehicle which is equipped with a self-steering axle is different from standard vehicles. In addition, there will be differences in the maneuverability of the vehicle in cases where the self-steering axle is locked or unlocked. Please be careful about the self-steering axles.

3.7.1.1. Locking The Steering Axle

For vehicles with Electronic Braking System (EBS), the self-steering axle can be locked automatically when the reverse gear is engaged in order to reverse. It is also possible to lock this axle manually.

Drive the vehicle straight ahead so that the steering axle is in a straight position before the steering axles will be locked.

If the automatic axle locking function is active in your vehicle, the steering axle

will be locked automatically when you engage reversing gear.

If you want to lock axles manually, make sure that the steering axle is in a straight position and close the valve (1) or turn the button to the off position.

The locking valve will be positioned towards you when the self-steering axle is locked manually.

 **Reversing with unlocked steering axles is dangerous. The semi-trailer can be separated from the tractor. Before going backwards be sure that self-steering axle is locked.**

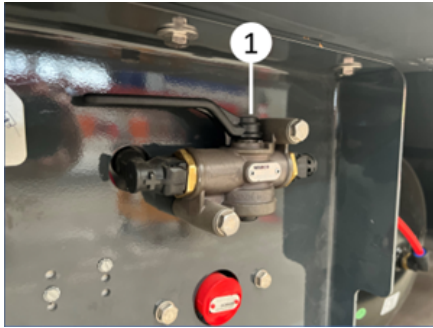

Self-Steering Axle Release Valve

3.7.1.2. Unlocking The Self-Steering Axle

The self-steering axles, which lock automatically when reverse gear is engaged, will automatically unlock when the vehicle is moving forward.

To release the manually locked self-steering axle, turn the valve handle 90° (2) clockwise or move the button to the open position.

 **When the self-steering axle is locked manually, the axle will not be unlocked automatically. It must be unlocked manually.**

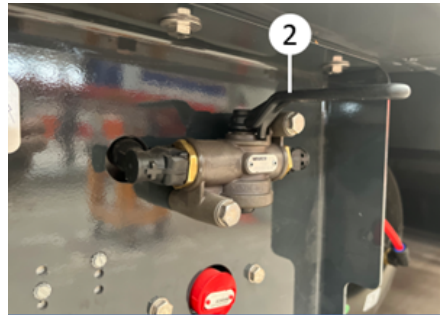

The Self Steering Axles Release Valve

3.7.2. Axle Lifting

Axle lifting feature is optionally available in different quantities and location in your vehicle. Thanks to this feature tire wear is minimized and a more balanced load distribution on the tractor can be provided. The EBS connection must be active for the axle lift load to work.

The axle lifting function is controlled automatically due to the legal regulations. When the speed limit is exceeded and the EBS is active, some axles can be lifted automatically, if the load on the axles is less than the maximum allowable axle load.

The driver may control the axle lifting manually for the maneuvering aid or traction help.

 **For the active traction help (raising the axle), the vehicle must be slower than 30 km/h and the technical capacity of the axles on the ground must not exceed 30%.**

When the trailer is in a park position, you may push the brake pedal 3 times and traction help (axle lifting) might be activated.

If your vehicle has optional axle lifting control from the tractor cabinet, it is

possible to manually lower/raise the axle with a spring loaded button to be installed in the tractor cabin. For this function, your tractor must be adjusted according to the trailer.

It is also possible to activate /deactivate the axle lifting function with a button on the trailer. Traction help can be activated by pressing and holding this button (1) for less than 5 seconds. If it is pressed more than 5 seconds, the axle can be lowered to the ground.

You can also find information about the axle lifting system stickers on the vehicle.

If you change the axle lifting configuration, your vehicle may be out of regulation. For this reason, the EBS modulator should not be checked or repair except by authorized services.

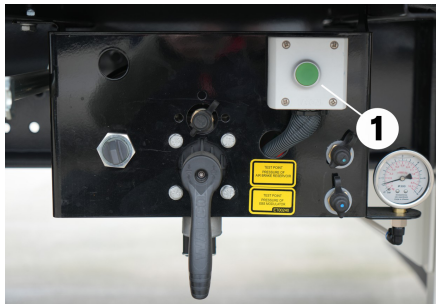

Spring button on the suspension control valve plate



Axle Lifting

There might be a pinching risk during the axle lifting or lowering.

3.7.3. Hubodometer

Hubodometers show the distance traveled by the vehicle in kilometers or miles.

The unit of the hubodometer is written on the hubodometer. It is adjusted according to the tire diameter.



Analog Hubodometer



Digital Hubodometer

3.8. Tires

When you are choosing tires, the first criteria are the load capacity index. Be sure that the load capacity index is suitable for your vehicle.

Tire manufacturers produce different types of tires according to the purposes of their use such as highway use, off-

road or mixed-use. Please choose the correct type of tires according to the road conditions that you will use the vehicle. Choose the low decibel as soon as possible version. Tires as possible as having to Class A fuel efficiency level and braking on wet surfaces according to EU tire label stickers.

 **You can see the EU tire labels of the tires which were used in your vehicle on our website.**

In dual/twin line wheeled vehicles, the tires must be matched properly according to their diameters. The tread depths on the adjacent tires shall not be different more than 5 mm. Furthermore, the newly coated tires and partially worn tires shall not be used side-by-side in relation to the structure and type of the vehicle. Otherwise, driving safety will be disrupted. In such tires, though the tread depths are seen, it must be deduced that the tire diameters are different and the tires exceeding the radius differences by 10 mm must not be used side-by-side.

Wrong matching will lead to excess shape deformation of the larger tire by carrying more load than necessary. In such a case, the wearing will accelerate and reveal the risk of early wearing of the tire. This case must be considered whenever radial and transverse layered tires are used side-by-side.



Tires

 In some countries, M+S (Mud and Snow) or 3PMSF (3 Peak Snowflake) labelled stickers can be mandatory according to season. Please observe the regulations and rules.



M+S and 3PMSF Symbol

 **Very serious accidents may occur if unsuitable or worn tires are used.**

3.9. Spare Wheel Holder

Different type of spare wheel holders is optionally offered in our vehicles.



Make sure that you put the necessary warning signs and take the safety precautions during the tire change.



Driving with insufficiently secured spare tire (s) can occur accidents.



The tires are heavy parts. Be careful about ergonomics and occupational health and safety rules during the tire replacement. There is a risk of pinching, falling, and cutting.



Spare wheel holder carriers are designed for special tires dimensions. Follow the rules and regulations when removing/mounting or maintaining the spare tire or spare wheel holder.

3.9.1. Crane Type Spare Wheel Holder

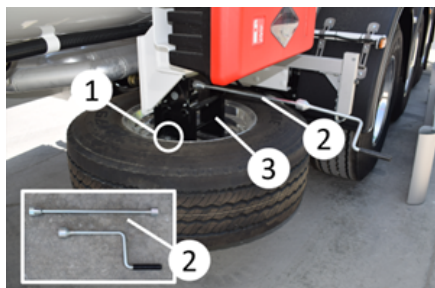

Crane type spare wheel holder

Removing the spare wheel:

- Remove the screws (2).
- Mount the lever (3) and turn it counterclockwise slowly. The spare wheel will be lowered.
- Remove the fixation parts (4) and take the spare wheel.

Placing the spare wheel:

- Mount the fixation parts (4) to the tire.

- Lift the tire upwards by turning the handwheel (3) clockwise.
- Turn the lever (3) clockwise and the tire will be lifted.
- Mount the screws (2) and fix the tire.
- Remove the lever (3) and store in the toolbox or cabinet.

3.9.2. Swedish Type Spare Wheel Holder

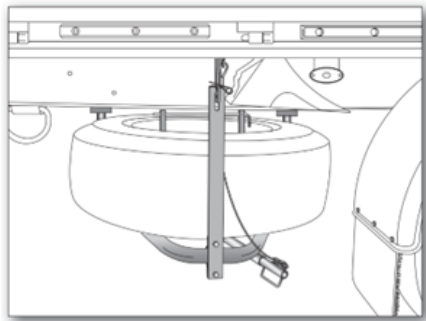

Spare Wheel Holder

Removing the spare wheel:

- Remove the pin (1) holding the upper retaining ring of the spare wheel holder.
- Remove the pawl hook fixing the spare wheel removal lever from the rings (2).
- Pull back the lowering arm (3) from the slot, released from the hook.
- Lift the holder slightly with the arm and release the top retaining ring from the hook (4).
- After releasing, lower the holder by means of arm slowly downwards.
- Release the arm by removing the pin of nut tightening/loosening arm (5) and pull it backwards and loosen the nuts by turning them anti-clockwise.

- After loosening the nuts, slide the spare wheel from the stopping pins and take it.

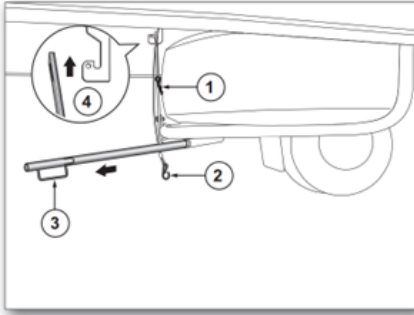

Removing The Spare wheel

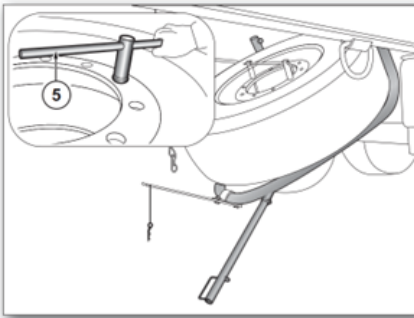

Removing The Spare wheel

Placing the spare wheel:

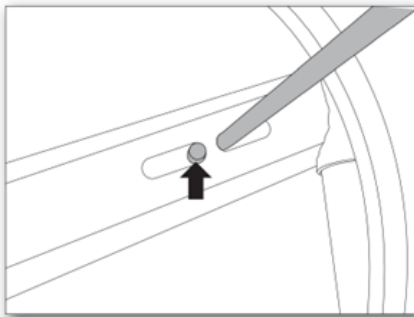

Mounting the spare wheel

- Put the tire onto the holder, position the stoppers to their seats and tighten both nuts by means of nut tightening/loosening arm.

- Then lift the holder with the arm and install the top retaining ring to the hook.
- Push the spare wheel lowering arm into the slot, firstly insert the hook then the top retaining ring and fix it to holder.

3.10. Mudguards

Your vehicle is equipped with mudguards and/or mudflaps which are suitable for regulations. The water will be splashed from the ground etc. will be minimized thanks to these mudguards and mudflaps.

Some vehicles may have foldable mudflaps in order to prevent mudflaps from damage. This type of mudflap has to be folded (1) during the huckepack operations.



When you are driving, the foldable mud-flaps must be opened.

3.11. Wheel Chock

There are two units wheel chocks and holders in the vehicle.



The vehicle must be secured with wheel chocks when parked on a slope area, during the loading and unloading operations or when parked without a tractor.



Only place wheel chocks on wheels on fixed axles, never on idle/steer axles.



When the wheel chocks is fixed inside the holder, be sure that the pins will be mounted properly.



After driving operations, place the wheel chocks properly.

3.11.1. Pin Type Wheel Chock Holder

Removing the wheel chock from holders: Pull out the cotter pin (1) located at the end of the wheel chock holder. Then take the wheel chock from its slot by pulling it sideways from the wheel chock holder.

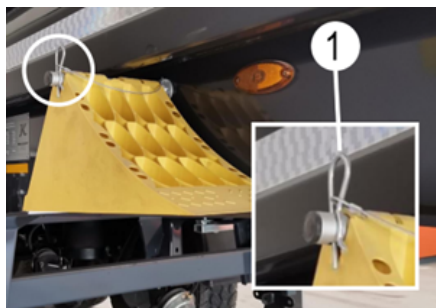

Wheel Chock

Placing the wheel chock from its holder: Place the wheel chocks on the holders and mount the cotter pin (1) to pin.

3.12. Boxes and Storage Units



Be sure that the boxes and storage units are properly closed and that the materials inside of these storage units are fixed properly before driving. Otherwise, the accident may occur.



Be sure that the necessary safety measurements are taken while using the cabinets and storage units.

3.12.1. Plastic Toolbox



Plastic toolbox

Unlocking The Toolbox:

- Remove the lock cover.
- Unlock by turning the key.
- Pull the lever towards you.
- Turn the lever and open the cabinet door.

3.12.2. Stainless Toolbox

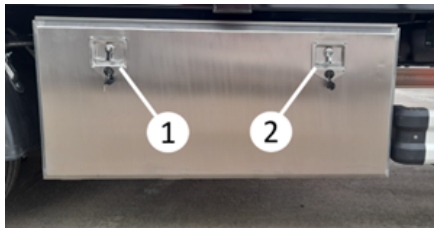

Stainless toolbox

Unlocking the box:

- First remove/ slide the lock's cover (1).
- Switch the key and unlock the locking mechanism.
- Pull the lever (2) towards you.

Turn the lever (2) and open the box cover.

3.12.3. Fire Extinguisher Cabinet

Fire extinguisher cabinets are used to protect fire extinguishers from the external environmental factors.

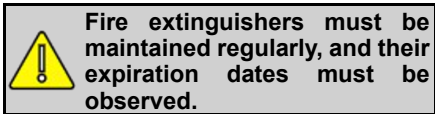

Fire extinguisher cabinet

Opening The Cover:

- Open the 2 plastic latches (1) which are holding the cover.
- Lift the latches up and back and open the cover.
- Remove the re-closable fasteners (black tape) in the fire extinguisher box and take the fire extinguisher.

Closing The Cover:

- Insert the fire extinguisher and fix it with re-closable fasteners (black tape).
- Close the cover first and after that put the latches to the top of the cover.

- Close the latches and lock the cover.



Unlocking The fire extinguisher cabinet

3.12.4. Water Tank



Water tank

The vehicle may have a water tank for general cleaning purposes. You can turn the tap and open the water. You can fill the water tank with the help of the filling neck which is located at the top of the tank.

There may be a soap dispenser on the water tank. You can disassemble and fill the soap dispenser by turning it counterclockwise.



Please be careful about the hygienic rules and regulations. The wastewater must be disposed of in accordance with the regulations of the country that you will be in.



The water in the water tank should not be drunk. It should be only used for cleaning purposes.



In cold weather, the water tank should be emptied. Otherwise, the water tank may be cracked because of the freezing water.



Store the locking pin and the document box cover properly. Otherwise, it might be lost.



Cylindrical type document box

3.12.5. Document Box



Square type document box

You may store your non-valuable documentation in the round or square type document box.

You can turn the cover of the round type document box counterclockwise and open the document box.

You may lift the pin of the square type document box and remove the pin. The cover of the square type document box may be opened.

3.13. Bumper

3.13.1. Lifiable Bumper



Lifting the bumper

The vehicle is equipped with liftable bumper in accordance with the Regulation EU 70/221.

- When you want to lift the bumper, you should unlock the locking mechanism, lift the bumper counterclockwise as shown in the figure and lock the mechanism to complete the procedure.



Lifiable bumper

- When you want to lower the bumper, you should unlock the locking mechanism, lower the bumper clockwise as shown in the figure and lock the mechanism to complete the procedure.

Driving with the bumper open is dangerous and prohibited by law. Otherwise, serious accidents even death may occur. The bumper should always be locked with the locking pin. Make sure that the pin locks the bumper!

3.13.2. Spring-Loaded Bumper

The bumper opening/closing operations now require less force, thanks to a mechanism that can be easily controlled with one hand. This improvement reduces operation time and increases user efficiency. The cushioning feature eliminates the risks of hard impact, rebound, and jamming during opening and closing.

Ensure that the Jost bumper lock is in the open position before folding the spring-loaded bumper.

After folding the bumper, make sure to return the Jost bumper lock to the closed position.



Spring-Loaded Bumper

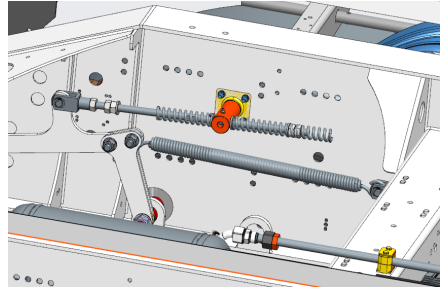

Spring Mechanism

3.13.3. Automatic Bumper

The automatic buffer system allows opening and closing via remote control and a control unit located on the chassis. The user can move the buffer in a controlled manner and without physical effort. This reduces processing time and increases operational efficiency.



Automatic Bumper



Automatic Bumper Control



Automatic Bumper

3.14. Ladders

Vehicle may have ladders which allow us to reach some areas of the vehicle more easily.

 Driving with a ladder which is not completely secured has serious hazards. During the driving operation, the ladder may way and injure the people. Use your vehicle with a completely secured ladder.

 Slips from the ladder may lead to accident. Polished, cleaned ladder must be used very carefully. Never use inappropriate means and tools to climb over or climb down the vehicle. Do not jump from the vehicle.

3.14.1. Access Ladder

The tipper is equipped with a fixed ladder on the front for climbing to the superstructure (tub).



Access ladder

3.14.2. External Ladder

The tipper is also equipped with an external ladder for accessing to the tub. The ladder is stored on the mudguards.



External ladder

In order to take out the external ladder;
Pull the pins out

4. UPPERSTRUCTURE COMPONENTS AND USE

4.1. Overview of the trailers upper structure components

Your vehicle has a self-supporting upper structure consisting of modular parts and mostly made from aluminum or steel sheets depending on your choice.

4.2. Body

4.2.1. Body Impermeability

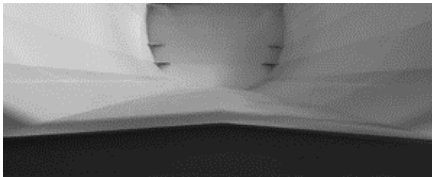

Welded floor

Combination of welded floor and side panels provides impermeability to the vehicle.

4.3. Front Panel



Front panel

- 1)Hydraulic Cylinder
- 2)Electric Socket Connections
- 3)Walking Platform

4.4. Rear Panel

Tipper vehicles contain 3 types of rear panels These are;

- Mechanical Rear Panel
- Hdyromechanical Rear Panel
- Combi (Double Leaf) Rear Panel

- Grain Door



Top-hung mechanical door



Double leaf/Top-hung combined door



Top-hung hydraulic rear door



Location of tightening locks



Grain door

4.4.1. Tightening Locks

The vehicle has tightening lock mechanism for safety.



Location of tightening locks

4.4.2. Mechanical Rear Door

Your vehicle may have mechanical rear door optionally. Door opens by itself when the tub is lifted.

The opening angle of the door raises if double hinged rear door option is selected.

4.4.3. Hydromechanical Rear Door

Rear door opens first when tub lift process begin. Then the tub raises. Rear door can be controlled by the control unit which located to chassis or remote control.

4.4.3.1. Controlling by control unit;

First, loosen and open the tightening locks which blocks the rear door.



Select the control unit with “Control Selection” button (1) as shown in the picture.

Opening Rear Door

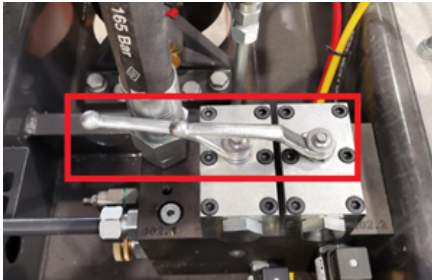

Turn the hydraulic valves to the position that will point the tub as shown in the picture.



You can open the door with pressing the “rear door” button (2) on the control unit.



Please check there are no-body in front of the vehicle and behind rear doors. Mortal injuries might occur in these situation.

Closing Rear Door

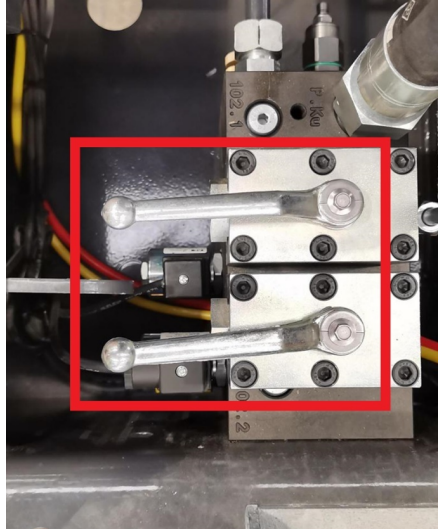

Turn the hydraulic valves to the position that will point right hand side due to driving direction.



You can close the door with pressing “rear door” button (3) on the control unit.



Please check there are nobody in front of the vehicle and behind rear doors. Mortal injuries might occur in these situation.

4.4.3.2. Controlling by remote control device;

First, loosen and open the tightening locks which blocks the rear door.



Select the remote control by switching the “control selection” button (1) as shown in the picture.

Opening Rear Door

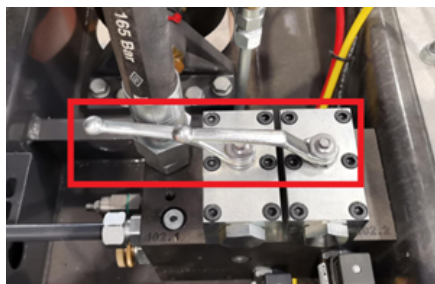

Turn the hydraulic valves to the position that will point the tub as shown in the picture.



You can open the door with pressing “rear door” button (2) on the remote control device.



Please check there are nobody in front of the vehicle and behind rear doors. Mortal injuries might occur in these situation.

Closing Rear Door

Turn the hydraulic valves to the position that will point right hand side due to driving direction.



You can close the door with pressing “rear door” button (3) on the remote control device.

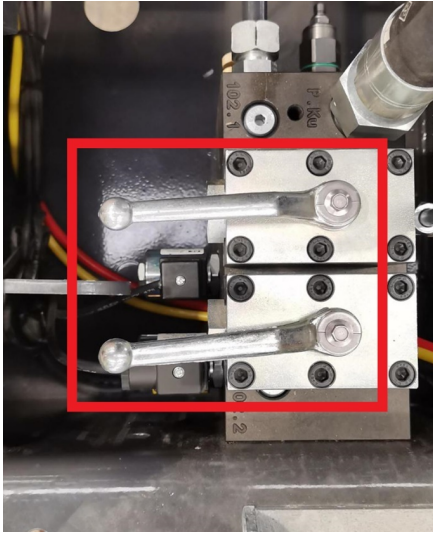

- 4. Grain Cover Handle
- 5. Grain Cover
- 6. Locking Pipe

4.4.4.1. Top-hung Rear Door Guide



Top-hung combined door opening

Tightening locks (1) must open when rear door wanted to open upwards.

4.4.4. Combi (Combined) Rear Door

Agricultural tipper vehicles combines the function of the classic top-hung rear door with the function of the leaf door. It can be used in two ways as needed.



Double leaf/Top-hung combined door

- 1. Door Handle
- 2. Tightening Locks
- 3. Bumper



Location of tightening locks

Tightening locks (1) are loosened by turning them counterclockwise.

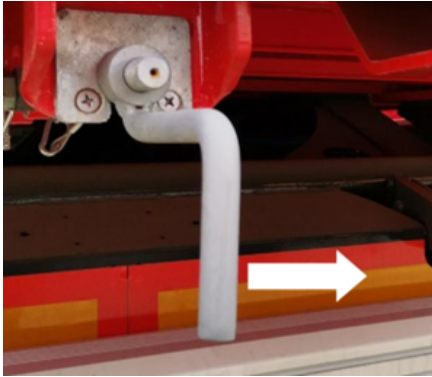

Loosening tightening locks

Door is opened when body started to lift.



Opening of top-hung combined door

4.4.4.2. Double Leaf Rear Door Guide



If double leaf rear door wanted to be used;

Door handle lock opens

Take out the pin (1),

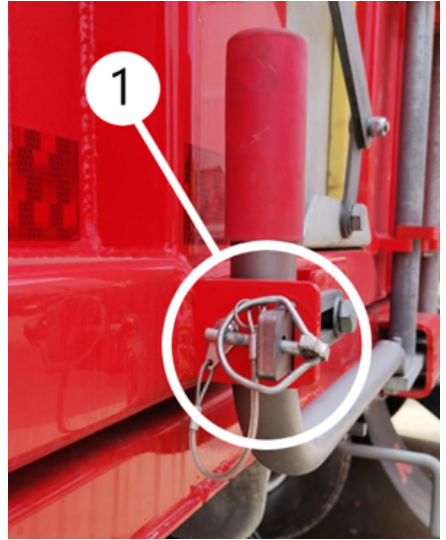

Door lock pin

Pull the lock holder to the direction (2) that shown in the picture and leave it in the position that doesn't block (3) the door handle.

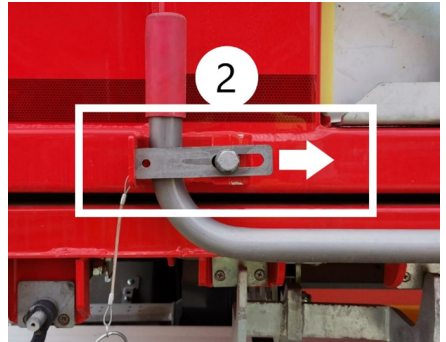

Opening door lock pin

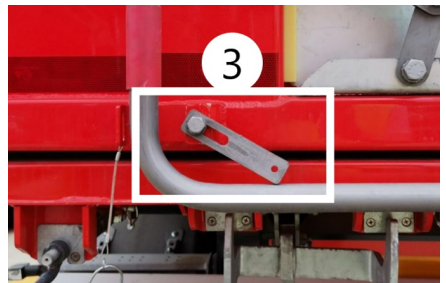

Opening door lock pin

Pull the door handle to you.



Pulling door handle

Right leaf door opens first, then left leaf opens.



Opening the door

Leaf doors are fixed to side panels with door fixing handle.



Door fixing handle location



Door fixing handle

4.4.5. Grain Door

Grain door is small discharging door located on rear panels.

Rear panels can be equipped with grain doors depending on your vehicle.

Please be sure that tightening locks and locking pipes are locked before operation.



Grain Door

4.4.5.1. Opening Grain Door

Grain door handle is loosened by turning it counterclockwise (1).

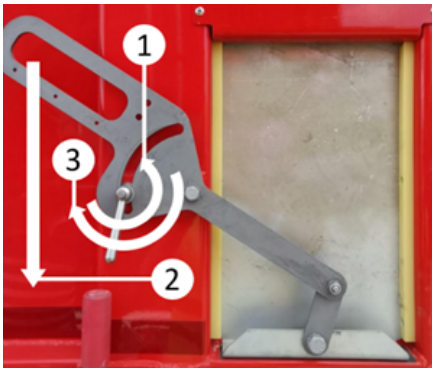

Pull the lever to the direction that shown in the picture (2), grain door will be opened.



Grain door handle is tightened by turning it clockwise (3).

4.4.5.2. Closing Grain Door

Grain door handle is loosened by turning it counterclockwise (1).

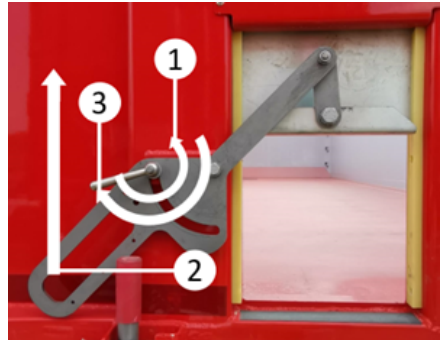

Pull the lever to the direction that shown in the picture (2), grain door will be closed.

Grain door handle is tightened by turning it clockwise (3).

4.4.6. Double Hinge

Thanks to the double hinge structure, the lid has a wider opening angle compared to standard systems. This design makes the opening movement of the lid two-stage, providing more controlled and safer movement on both horizontal and vertical axes.

With the improved hinge geometry, access to the vehicle's loading and unloading area is increased when the lid is opened. The increased opening angle

offers ergonomic advantages to the operator, especially during operations in narrow spaces, and enhances ease of use.



Double Hinge

4.5. Grain Bag

Your tipper may have equipped with a grain bag depending on your vehicles configuration.



There are 1 or 2 units of grain bag holders that located on the chassis in order to store them.

4.6. Walking Platform and Access Ladder

Walking platform comes with aluminum side pipe tarpaulin. It can be selected as aluminum or steel optionally. Access ladder can be selected as an option for automatic and mechanical tarpaulins.

4.7. Lifting and Lowering the Tub

The operation of lifting – lowering is controlled by a equipment which is located in truck.

4.7.1. Lifting the Tub with Joystick

With the vehicle running, keep your foot pressed on the clutch pedal.

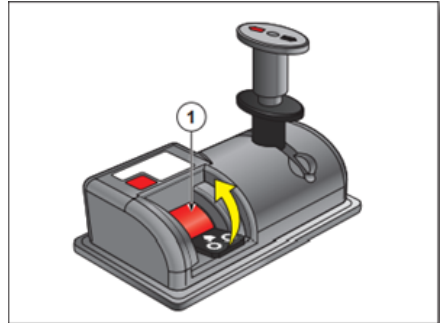

Activating the PTO

Move the PTO switch (1) in the direction indicated by the arrow to top position. PTO will be activated.

Release the clutch pedal once the PTO is activated.

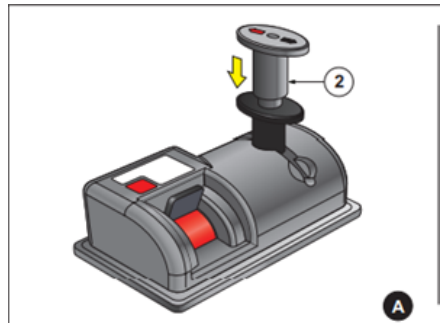

Pressing the joystick in the direction of the arrow



pushing the joystick in the direction of the red arrow at the top

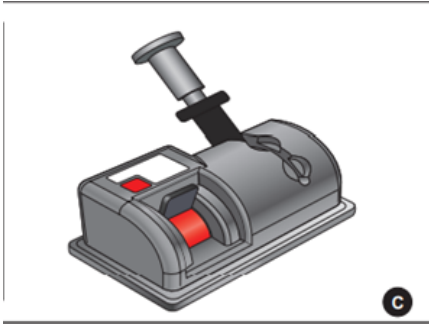

Fitting the joystick into its slot

After activating the PTO, move the lifting/lowering lever (2) downwards (A). At this position, move the lifting/lowering lever forward in the direction indicated by the red arrow sign on the lever (B). After engaging the lifting/ lowering lever to position, move it to the idle position (C). At this position, the hydraulic piston will be activated and lift the tipper.

When it reaches to topmost position, it will be stopped by the bucket stop. However, the PTO will keep running.

Move the lifting/lowering lever in the direction indicated by the yellow sign to stop the PTO (A). At this position, move the lifting/lowering lever backwards in the direction indicated by the black arrow (B) and bring it to the middle position (C). At this position, the PTO will be stopped and the hydraulic piston will be deactivated.

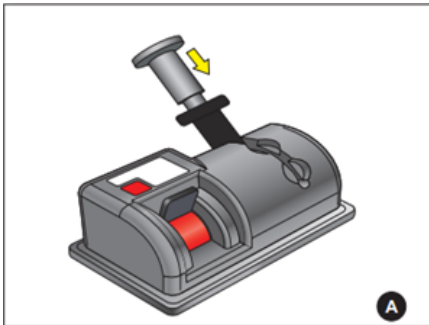

Pressing the joystick in the direction of the yellow arrow

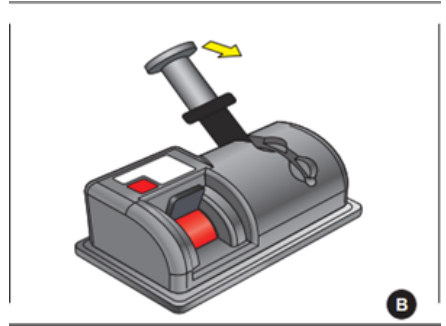

Pulling the joystick in the direction of the black arrow

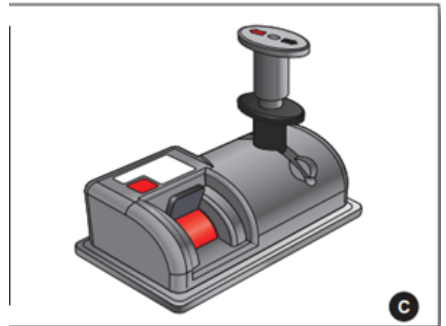

Bringing the joystick to the middle position

4.7.2. Lowering the Tub with Joystick

Move the lifting/lowering lever (1) downwards in the direction indicated by the arrow (A). At this position, move the lifting/ lowering lever backwards in the direction indicated by the black arrow (B). At the same time, the PTO switch (2) will automatically move to closed position and the bucket will start lowering with its own weight. After engaging the lifting/ lowering lever to position, move it to the idle position (C).

Once the bucket has lowered completely, move the lifting/lowering lever (1) downwards (A). At this position, move the lifting/lowering lever forward in the direction indicated by the red arrow sign on the lever (B) and engage it to the middle position (C).

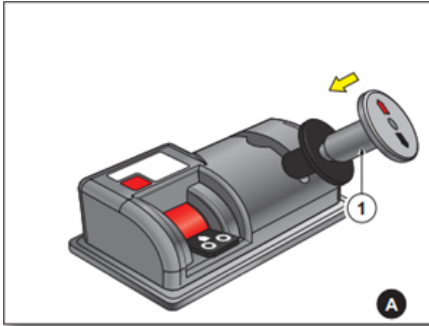

Pressing the joystick in the direction of the yellow arrow

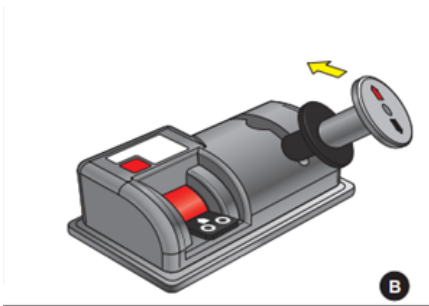

Pushing the joystick in the direction of the red arrow



Bringing the joystick to the middle position

4.7.3. Lifting the Tub with Switch

With the vehicle running, keep your foot pressed on the clutch pedal.

Move the PTO switch (1) in the direction indicated by the arrow to top position. PTO will be activated.

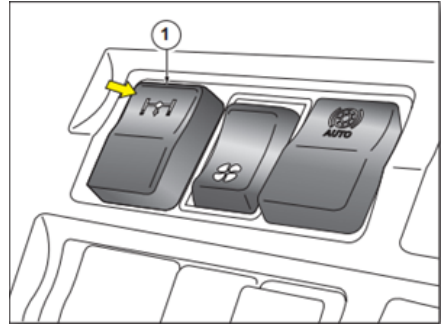

Bringing the PTO button up position

Release the clutch pedal once the PTO is activated.

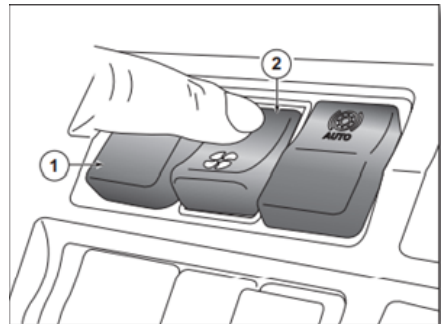

Pushing the lifting button

The lifting button is kept pressed until the load is unloaded.

4.7.4. Lowering the Tub with Switch

The clutch pedal is pressed.

With the clutch pedal pressed, the PTO switch is moved to off position.

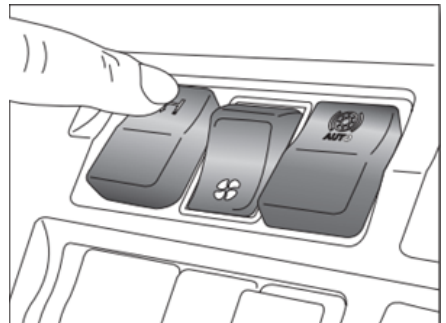

Bringing the PTO button to turned off position

With the clutch pedal pressed, the PTO switch is moved to off position.



Pushing the lowering button

Once the lowering operation has been completed, the lowering button is turned off.

The same procedure is followed at the next lowering and lifting.

4.7.5. Lifting the Tub with Remote Control Device

Select the remote control device with turning the “Control Selection” (1) key that will point the remote control device in order to control the tub with it.



Selecting remote control device

Turn the hydraulic valves to the position that will point the tub in order to take the tub to lifting mode.

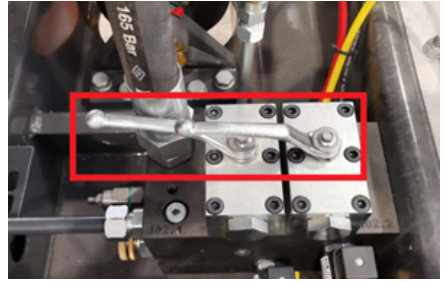

Turning valves on position

The tub is lifted by pushing “front cylinder” (2) button on the remote control device.



Lifting the tub with pushing front cylinder button on the remote control device

4.7.6. Lowering the Tub with Remote Control Device

Turn the hydraulic valves to the position that will point right hand side due to driving direction in order to take the tub to lowering mode.

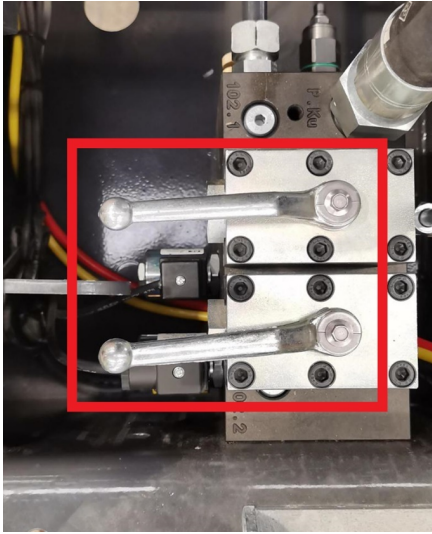

Turning valves off position

The tub is lowered by pushing “front cylinder” (1) button on remote control device.



Lowering the tub with pushing front cylinder button on the remote control device

4.7.7. Lifting the Tub with Remote Control Device

Select the remote control device with turning the “Control Selection” (1) key that will point the remote control device in order to control the tub with it.



Selecting remote control device

Turn the hydraulic valves to the position that will point the tub in order to take the tub to lifting mode.

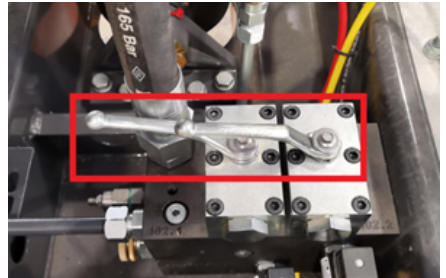

Turning valves on position

The tub is lifted by pushing “front cylinder” (2) button on the remote control device.



Lifting the tub with pushing front cylinder button on the remote control device

4.7.8. Lowering the Tub with Remote Control Device

Turn the hydraulic valves to the position that will point right hand side due to driving direction in order to take the tub to lowering mode.

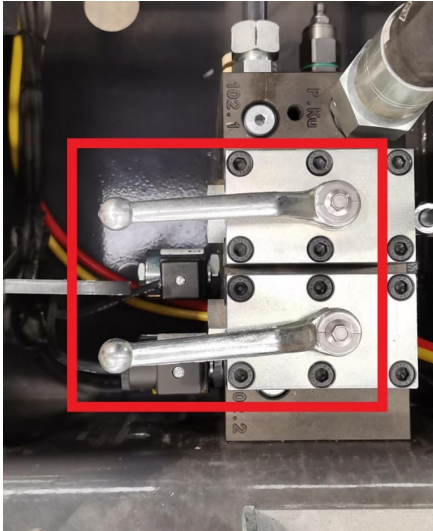

Turning valves off position

The tub is lowered by pushing “front cylinder” (1) button on remote control device.



Lowering the tub with pushing front cylinder button on the remote control device

4.8. Tarpaulin

4.8.1. Rolling Aluminum Pipe

4.8.1.1. Tarpaulin Mechanism

Rolling aluminum pipe is given as a basis for tipper vehicles.

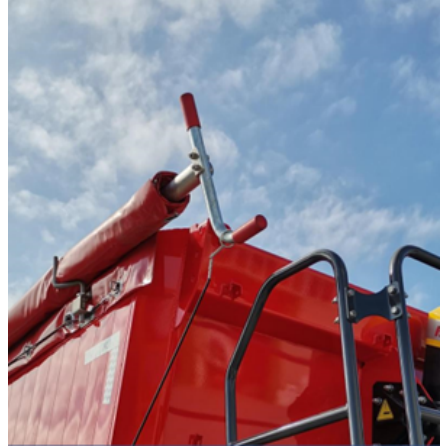

Rolling aluminum pipe tarpaulin

To roll the pipe, remove the cotter pin which shown in the figure 1.



Figure 1

Tensioning chain should be attached before closing the tarpaulin as shown in the figure 2.



Tensioning chain – Figure 2

The pipe rolls in clockwise as shown in the figure 3 and rolls until it reaches other edge of the tub.



Figure 3

Tarpaulin must be fixed to hooks which riveted to the tub after closed completely as shown in the figure 4. Apply the instructions reversed for opening the tarpaulin.



Figure 4

Aluminum pipe is fixes to its hook which located in front side of the vehicle.

For tensioning the tarpaulin rope;

There is a rod which is used for attaching the tensioning ropes to hooks. It is located on the chassis.

Take out the rod with removing cotter pin that shown in the figure.



Attach the ropes to hooks with using the rod.



4.8.1.2. Adjustable Tarp Arm

The mechanical control of the manual tarpaulin arm used for opening the tarpaulin is ensured. Thanks to the mechanism used, the arm can be turned without rolling the tarpaulin when the arm is pulled. It allows the lock to be easily adjusted for tight or loose rolling of the tarpaulin. To disengage the mechanism and adjust the arm to the desired level, the arm is pulled outward. When the nested structure is released from its slot, it can rotate freely. After setting the desired position, the arm is released,

and the operation continues in the new position.



Adjustable Tarp Arm

4.8.2. Automatic Tarpaulin

Tarpaulin control unit is located on the chassis as shown in the figure.



Tarpaulin control unit location

4.8.2.1. Opening the Tarpaulin

Please check if there is any object to block tarpaulin movement.

Turn the key to the I position (1) on the control unit.



Turning the control unit on

Open the tarpaulin by turning the key shown in the picture to the **UNCOVER** position (2) or by pressing the **[B]** button on the remote control device. Make sure you open the tarpaulin all the way.



Opening the tarpaulin with control unit



Opening the tarpaulin with the remote control device

Note: The control unit has an automatic stop system for the motor. This system enters into operation when the tarpaulin reaches the limit stop.

Check that the tarpaulin clamping hooks are positioned correctly in their hooks and fasten any safety cables or elastic cords.

Turn the key to the **0** position (3) on the control unit.



Turning the control unit off

4.8.2.2. Closing the Tarpaulin

Please check if there is any object to block tarpaulin movement.

Turn the key to the **I** position (4) on the control unit.



Turning the control unit on

Close the tarpaulin by turning the key shown in the picture to the **COVER** position (3) or by pressing the **[A]** button on the remote control. Be sure to close he tarpaulin all the way.



Closing the tarpaulin with the control unit



Closing the tarpaulin with the remote control device

Check that the tarpaulin clamping hooks are positioned correctly in their hooks and fasten any safety cables or elastic cords.

Turn the key to the **0** position (3) on the control unit.



Turning control unit off

4.8.3. Mechanical Tarpaulin

4.8.3.1. Opening the Tarpaulin

Please check if there is any object to block tarpaulin movement.

Branda üzerindeki elastik kordonları ve güvenlik kablolarını çıkarınız.

Free the rotation rod (A) removing the snap pin (B) from the support (C).

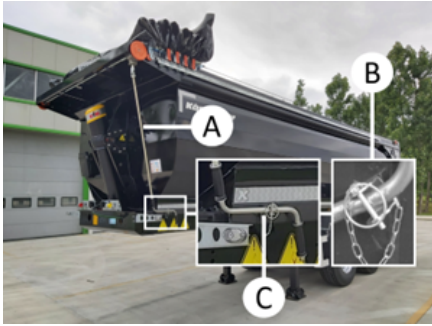

Removing the hand crank from its seat

Hold the rod and turn the hand crank (D) to cover the container.

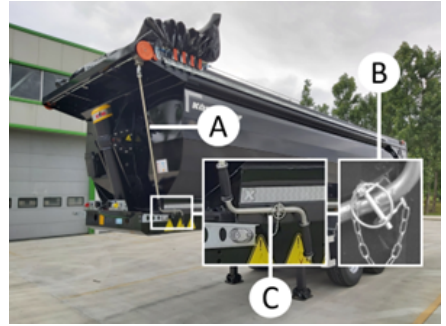

Removing the hand crank from its seat

Hold the rotation rod and turn the hand crank (D) to uncover the container.

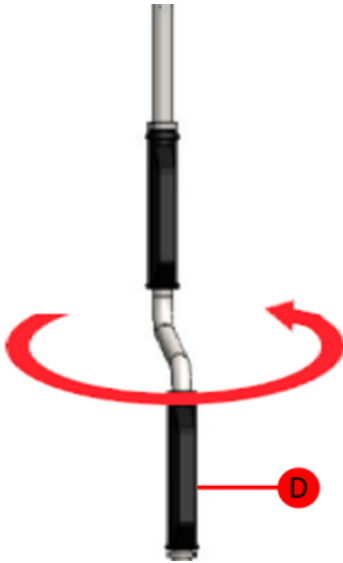

Using of hand crank

Position the rotation rod in the support and tension the tarpaulin.

Insert the snap pin in the support.

If automatic closure is not present, manually close the rear cover.

4.8.3.2. Closing the Tarpaulin

Please check if there is any object to block tarpaulin movement.

Free the rotation rod (A) removing the snap pin (B) from the support (C).

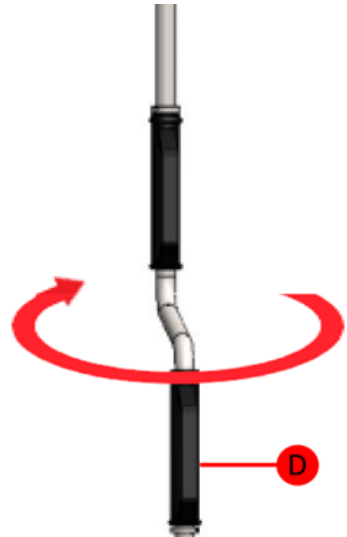

Using of hand crank

Once the operation has been completed, block the rod again.

Check that the tarpaulin clamping hooks are positioned correctly in their hooks and fasten and safety cables or elastic cords.

4.9. Hydraulic System

4.9.1. Tipping Cylinder Connection



During the coupling of the truck and the tipper, while making the hydraulic connection of the cylinder, the working pressure of the pressure valve used on the tractor should not exceed the working pressure of the cylinder located on the tipper. The pressure valve must be selected according to the pressure value specified on the cylinder.



Otherwise, excessive pressure in the tipper cylinder during operation may result in deformation and damage. In such cases, any damage caused will not be the responsibility of our company



Hydraulic Coupling Diagram



A pressure valve suitable for the operating pressure of the hydraulic cylinder must be selected.

4.10. Hydraulic Piston

4.10.1. Hydraulic System Connection Points

4.10.1.1. Way Hydraulic Gear Pump Use

A gear pump sends through the pressure line the hydraulic oil from the suction line after accelerating it with the rotating and

turning gears. Thus the mechanical energy from the motor is converted to hydrostatic energy.



Gear pumps work with suitable hydraulic oils only.

4.10.1.1. Connection Method

Determining the Return Direction and Suction Pressure Lines

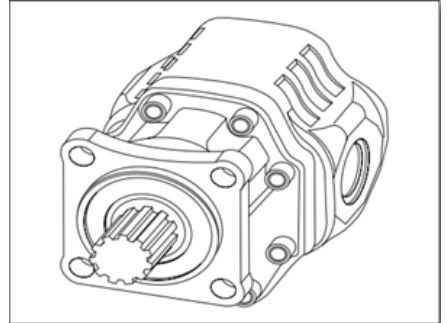

Two way hydraulic rear pump

The two way hydraulic gear pump is not pre-defined as rotating right or left. The pump can be operated with right-hand rotation (clockwise) or left-hand rotation (counterclockwise) as desired. However, you should keep operating it in the direction preferred initially. Otherwise the volumetric efficiency of the pump will decrease and its service life will become shorter.

4.10.2. Pump – PTO Connection

The pump should turn RIGHT (clockwise) if the main transmission turns RIGHT and the auxiliary transmission is connected.

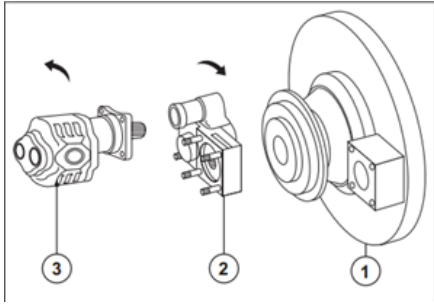

Pump – PTO connection

- Main Transmission
- Auxiliary Transmission (Connected)
- Gear Pump

The pump should turn RIGHT (clock-wise) if the main transmission turns RIGHT and the auxiliary transmission is connected.

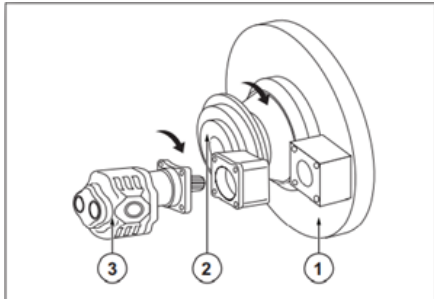

Pump – PTO connection

- Main Transmission
- Auxiliary Transmission (Connected)
- Gear Pump

4.10.2.1. Hydraulic Oil

Hydraulic Oil Operating Temperature

The minimum operating temperature is -23°C while the maximum operating temperature is 82° C. The ideal operating temperature for the oil in the system is 35°C to 55°C.

- Mineral based hydraulic oil should be used in the system.
- The viscosity of the hydraulic oil in the system should be 12 to 100 cSt (mm²/s). The ideal viscosity is 20 to 40 cSt.
- Low viscosity hydraulic oil should be preferred in cold weather and high viscosity hydraulic oil should be preferred in hot weather.

KIŞ AYLARINDA	YAZ AYLARINDA
ISO VG32 HLP (VISCOSITY AT 40 °C)	ISO VG32 HLP (VISCOSITY AT 40 °C)

Filtering

- The system must be equipped with an oil and an air filter. The oil filter should not be used on the pump suction line but on the tank return or pressure line.
- The most efficient filtering is 10 µm. Filtering up to 25 µm is allowed.
- The filters should be checked periodically.

Oil Warning Hole

The oil warning hole on the cover of the pump (1) is provided to warn the operator in case of a problem with the oil seals in the cover.



It should be periodically checked whether oil comes out from the oil warning hole. When oil coming out of the oil warning hole is spotted, the product should be taken to the nearest service centre.

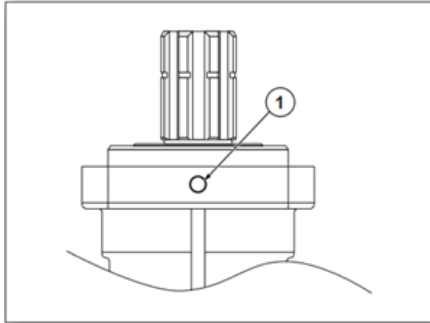

Oil Warning Hole

4.10.2.2. Operating Instructions

Before Starting the Pump

- It should be checked whether the flow rate and the pressure of the pump is suitable for the pressure and oil demand of the system.
- It should be checked whether the pump connection was made in accordance with ISO or UNI connection.
- The tank should be filled to the maximum with fresh oil at proper viscosity. It should be checked that the oil filter is not connected to the pump suction line. The oil filter should be mounted on the tank return or pressure line. If the oil filter is connected to the pump suction line, the pump cannot get sufficient oil from the tank. This leads to overheating and cavitation in the pump which results in a drop in the efficiency and service life of the pump.
- Prior to the initial start, it should be checked that the system is filled with oil up to the pump inlet and all valves are open. The pump should

never be operated without oil, even for a second.

Operating the Pump

- The initial operation should be carried out without pressure at low speed (idle speed for trucks) with the tipper empty for a few minutes and the operation, noise and any oil leakage of the pump should be checked. When something extraordinary is noticed, the system should be stopped and the problem should be located.
- Since the system will be filled with oil after the initial start, the tank level should be checked again and topped up.
- The pump should not be operated above the pressure and speed values mentioned.
- The pressure setting of the direction control valve should not be changed.
- The periodical maintenance of the system should be carried out in due time.
- You should contact our service centres for any problems.



If the instructions before and during the operation of the pump are not followed, the product warranty will be void.

4.10.3. Use of Telescopic Cylinder

Operating Temperature

- The operating temperature of the oil in the system is between 35 - 55°C.
- The minimum operating temperature is -23°C while the maximum operating temperature is 82°C.

Hydraulic Oil

- Mineral based hydraulic oil should be used in the system and it should be replaced every 6 months.
- The viscosity of the hydraulic oil in the system should be 12 to 100 cSt (mm²/s). The ideal viscosity is 20 to 40 cSt.
- Low viscosity hydraulic oil should be preferred in cold weather and high viscosity hydraulic oil should be preferred in hot weather.

KIŞ AYLARINDA	YAZ AYLARINDA
ISO VG32 HLP (VISCOSITY AT 40 °C)	ISO VG32 HLP (VISCOSITY AT 40 °C)

Filtering

- The system must be equipped with an oil and an air filter. The oil filter should not be used on the pump suction line but on the tank return or pressure line.
- The most efficient filtering is 10 µm. Filtering up to 25 µm is allowed.
- The filters should be checked and serviced periodically.

Issues to be Considered for Installation

- The cylinder should be painted after the stage pipes are well covered. When paint adheres to the stage pipes, the paint residues deform the cylinder seals after drying and cause oil leaks.
- The brackets must be mounted on a flat and strong surface.
- It should be ensured that the cylinder and bracket connection planes are perpendicular. Because the cylinder does not work properly when tightened; stage misalignment and deformation of the pipe and oil leakage occur over time.
- It should be mounted according to the space that will allow the movable joints to adjust themselves

according to the load and the ground. It should be noted that the connections are made not tightly, but by leaving a gap.

- The closed length of the cylinder after mounting to the tipper or trailer must be minimum 20 mm and maximum 50 mm more than the closed length before the cylinder is mounted.
- When the stages of the cylinder are opened, care should be taken to leave a safe distance so that the last stages do not touch the casing.

Points to Note When Operating the Cylinder

- The vehicle must be on a smooth and strong ground.
- The vehicle should not be moved with the tipper open.
- The driver should not leave the vehicle while it is operating.
- The operations should be carried out at a location with sufficient light.
- It should be checked before unloading that the rear doors are open.
- The flowability of the load should be checked; stable loads might give significant damage to the system and the vehicle.
- No persons should be present in the vicinity of the tipper during operation of the cylinder. Any tripping might result in serious and fatal injuries.
- The engine speed of the vehicle should not be increased excessively during the operation of the cylinder; it might damage the cylinder significantly.
- The settings of the pressure control valve should never be changed.

- The connection points should be greased at regular intervals.



These warnings are intended for safety of you and your property. The damages that might occur if these warnings are ignored will not be covered by the warranty and the warranty will be void.

5. TRANSPORTATION PROCESS

5.1. Pre-Driving Checks

- All necessary documents are in the vehicle,
- Required adjustments and suitability of the loading situation,
- The vehicle is properly tied and secured to the tow truck.
- All pneumatic and electrical connections between the semi-trailer and the tractor are made properly and the EBS system is in working condition,
- All necessary equipment (chocks, underrun protection, ladders, etc.) is in place and properly locked or secured,
- The loads are correctly distributed to prevent displacement while driving,
- The load weight is within the allowable limits,
- The regulations of the country you are in are complied with,
- The lighting and signal system is fully functioning,
- Tire air pressures are at the required level,
- Check that the parking brake of the semi-trailer is released.
- All valves and manhole covers are closed and secured,
- The material hoses are safely lifted.

5.2. Semi-Trailer and Tractor Coupling

Apply the following steps to couple the semi-trailer with the tractor:

- Check that kingpin and its couplings are normal . Make sure that there is an adequate amount of grease oil

on the fifth wheel, top-connection plate and kingpin that will prevent damage when coupling and that it does not contain any dust and contaminant.

- Lower the height of the rear suspension airbags of the tractor until it can be inserted in the king pin section of the semi-trailer.
- Set the 5th wheel locking system on the tractor to the "On" position.
- Adjust the height of the semi-trailer to insert it into the tractor. The height of the semi-trailer can be adjusted with the mechanical landing gear. Prevent the movement of the semi-trailer by using the parking brake. Put wheel chock at the rear of the wheels for safety.
- Move the tractor, fifth wheel until it touches the top-connection plate of the semi-trailer and moves backwards slowly on the same level. The fifth wheel will slide smoothly under the top-connection plate and enter the kingpin's shoes and lock automatically with the intensity of impact.
- Raise the landing legs of the semi-trailer and insert the landing legs arm to its place.
- Connect the air, electrical and EBS cables and hoses to their places on the tractor. Be sure that all the functions are working properly.
- If the vehicle has a parking brake, release the parking brake.



If your vehicle is driven at the wrong 5th wheel height, malfunctions may occur in the vehicle. You may have height problems.. The vehicle must be driven at the correct fifth wheel height.

Apply the following steps to uncouple the semi-trailer with the tractor:

- If the vehicle is equipped with service type brake chambers, apply the parking brake after checking the brake drum. Never apply the parking brake when the brake drums are very hot. (The drum may crack.)
- If the vehicle has a hand-brake type brake, put a wheel chock in front of the vehicle. Apply the handbrake.
- Disconnect the brake air lines, the brake will be applied automatically. Disconnect the semi-trailer electrical connections.
- Lower the mechanical landing gear of semi-trailer (use high speed). When the mechanical landing gear feet or wheels touch the ground, switch the mechanical landing gear crank handle to low-speed position to raise the semi-trailer.
- Unlock the fifth wheel lock. Separate the tractor from the semi-trailer about 500 mm by slowly moving the tractor forward. Lower the level of the rear suspension airbags of the tractor and leave the semi-trailer's bottom.

To ensure that that the king pin is locked properly, engage the first gear of the tractor, and press the gas pedal, when you are slowly releasing the clutch, you will feel that the tractor strives to move the semi-trailer, this indicates that the connection is made properly. During the travel, this connection must be checked carefully to prevent separation of the semi-trailer from the tractor accidentally.

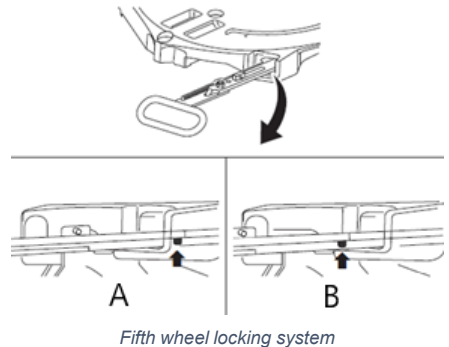



A- Locked

B- Unlocked

5.3. Loading – Unloading Operations

Accident hazards arising from loading and unloading and load securing process performed not professionally.



Safety Reminder

- During the loading/unloading operations, the parking brake must be activated, and the vehicle must be fixed with Wheel chocks.
- To prevent slipping, tipping or sinking of the vehicle, the vehicle must be parked on a flat and firm surface.
- Ensure that you made a proper load distribution in compliance with all laws, rules and regulations.

- The suspension of the vehicle may be raised during the loading/ unloading process. Because of this reason, the vehicle height may be bigger than the permitted height limits. Always set the trailer in the driving position after loading and unloading. Always check height limits when entering tunnels and passages.
- Make sure that the weight or dimensions of the load do not exceed the technical and legal limits.
- Note that vehicle stability may be affected by the load distribution, the braking distance may be longer and a larger turning radius may be required.
- During loading, consider the laws of the countries you are going to and passing through, as well as the laws.
- Give attention to the maximum axle weight and total weight.
- Comply all national/international laws, rules, and regulations about loading and occupational safety.

5.4. Cautions During the Parking and Stopping

- Involuntary trailer movements, unstable posture and insufficient safety at night may occur serious accidents and injuries.
- Use the parking brake and wheel chocks while stopping.
- If you are going to park the vehicle in a public traffic area, you must use the necessary marking plate in accordance with legal regulations.

5.5. Loading

- The load must be secured so that it does not move while the vehicle is in motion or during sudden stops.

- Distribute any load as low as possible on the loading floor. The load's center of gravity must always be above the vehicle's centerline.
- If a roof lift or sliding roof system is used, make sure the system is made suitable for driving.
- Make the tensions by making the canvas connections securely.
- Secure the load with brackets and load holders and make sure it is secure.

5.6. Important Technical Considerations

5.6.1. Fire Extinguisher

Please check fire extinguishers periodically every year and fill them up if necessary. In case of any usage of the fire extinguishers, fill it up immediately.

Precautions to be taken in case of fire.

Some sealing materials let out gas when burned and these gases may become abrasive acid in contact with water. Thus never touch the fire extinguisher liquid accumulations without wearing protective gloves.



Fire extinguisher box

5.6.2. Wheel Chocks

Keep the wheel chocks in their place and place them under the wheels during parking. Do not forget to remove the wheel chocks before setting off.



Wheel chocks

5.6.3. Treylerde Yapılacak Değişiklikler

Treyler üzerinde yetkili servis dışında herhangi bir işlem yapılmamalıdır, Treyler'e yetkili servis dışında yapılan değişiklik/tamiratlarda araç garanti kapsamı dışına çıkar.

5.6.4. Air Leakage

In case the air pressure in the air tubes drops instantly with the engine stop, this means that there is a leakage in the pneumatic system. Contact the nearest authorized service in such a case. The air leakage not only affects the safety of the braking system but also negatively affects the load lifting capacity of airbags.

5.6.5. Considerations For the Environment

Pollution in all its forms poses a threat to the environment. To keep the pollution at a minimum, collect the waste materials carefully and dispose of them in accordance with the regulations of your country.

ENVIRONMENT - Disposal of the battery in an inappropriate place may harm the environment and human health. If you need to dispose of the battery, follow local regulations. If you do not know how to dispose of it, take it to the most

appropriate service point. The symbol on the battery indicates that this product should not be disposed of.



Health and Safety

- Keep sparks and fire away from the battery. The battery emits explosive gas that can cause an explosion.
- Wear eye protection and rubber gloves while working on the battery, otherwise the battery hand-control may cause burn and serious damage including blindness in your eyes.
- Under no circumstances allow children to handle the battery. Make sure that anyone dealing with the battery is familiar with the proper use of the battery and its hazards.
- Pay close attention to the battery electrolyte as it contains diluted sulfuric acid. Contact with your skin and eyes may cause burns or loss of eyesight.
- Carefully read and understand this manual before working on the battery. Failure to follow instructions may result in injury and vehicle damage.
- Do not use the battery if the electrolyte level is at or below the recommended level. Using the battery with a low electrolyte level can cause explosion and serious injury.

If there are wasted oil and wasted oil contact materials in your vehicle, pay attention to the following warnings.

When disposing of products/wastes such as used oil, hydraulic oil, do not

discharge into channels, sewers, landfills, or soil. This is against the legislation of all countries.

This rule also applies to empty containers in contact with oil, chemical materials, and waste of cleaning cloths. Take these wastes to the relevant authorities or the most appropriate service point for disposal.

If your vehicle tire has expired;

The end-of-life tire must be disposed of in accordance with the regulations. For this, take your expired tire to the relevant authorities or appropriate service points.

If you carry dangerous chemicals in your vehicle;

In case of an accident or emergency that may occur during transportation, act in accordance with the Written Instructions of the ADR Legislation.

From the trailer's life-cycle perspective, it is important to recycle the end-of-life vehicle in an environmentally friendly manner. A large part of the trailer consists of recyclable materials. Contact the approved company and appropriate service for the recycling of the trailer that has expired.

6. LOADING AND LOAD SECURITY

6.1. Loading – Unloading Operations

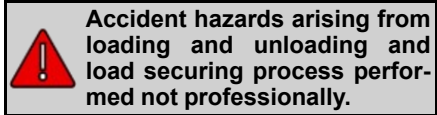

Safety Reminder

- During the loading/unloading operations, the parking brake must be activated, and the vehicle must be fixed with Wheel chocks.
- To prevent slipping, tipping or sinking of the vehicle, the vehicle must be parked on a flat and firm surface.
- Ensure that you made a proper load distribution in compliance with all laws, rules and regulations.
- The suspension of the vehicle may be raised during the loading/ unloading process. Because of this reason, the vehicle height may be bigger than the permitted height limits. Always set the trailer in the driving position after loading and unloading. Always check height limits when entering tunnels and passages.
- Make sure that the weight or dimensions of the load do not exceed the technical and legal limits.
- Note that vehicle stability may be affected by the load distribution, the braking distance may be longer and a larger turning radius may be required.
- During loading, consider the laws of the countries you are going to and passing through, as well as the laws.
- Give attention to the maximum axle weight and total weight.

- Comply all national/international laws, rules, and regulations about loading and occupational safety.

6.2. Loading

- The load must be secured so that it does not move while the vehicle is in motion or during sudden stops.
- Distribute any load as low as possible on the loading floor. The load's center of gravity must always be above the vehicle's centerline.
- If a roof lift or sliding roof system is used, make sure the system is made suitable for driving.
- Make the tensions by making the canvas connections securely.
- Secure the load with brackets and load holders and make sure it is secure.

6.3. Safety Instructions

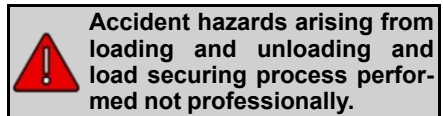

- Make sure that the cargo is properly distributed and in accordance with all laws, rules, and regulations. Check the loading limits, total weight, and axle load capacities. Do not exceed the weight limits which are defined in the user manual and identification plate. Comply with all national/international laws, rules and regulations about loading and occupational safety.
- Place the Cargo as close as possible to the loading area's floor. The center of gravity of the load must always be on the center line of the vehicle. Be all the regulations and laws about load security.
- While all vehicles are being designed, except for specific ones, it is assumed that the load will be

distributed evenly on the load carriage surface and the calculations are done accordingly. Thus, the load up to the maximum carrying capacity of your vehicle must be distributed to ensure that equal weights are at the unit areas over the utilized carriage area. When the point loads are to be carried, a rigid distribution platform must be placed under the load that will place the load up to the unit area capacity of the semi-trailer.

- While loading by crane or forklift, make sure that there is no one under and around the load.
- During the loading operation, do not exceed the permissible maximum height. A loading performed within the specified loading limit will ensure that you keep away from traffic accidents.
- It is dangerous and prohibited to fix the load to the vehicle surface via a tool apart from the permissible equipment.

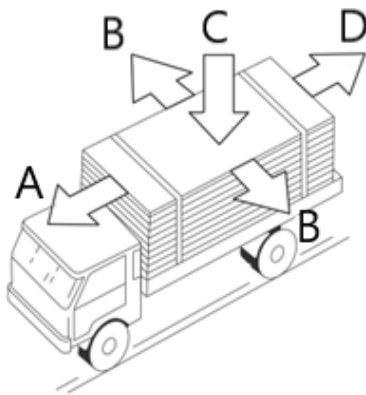

Forces may affect the vehicle

- A- Brake Force
- B- Centrifugal Force
- C- Static Weight Force
- D- Ramp / Hill Force

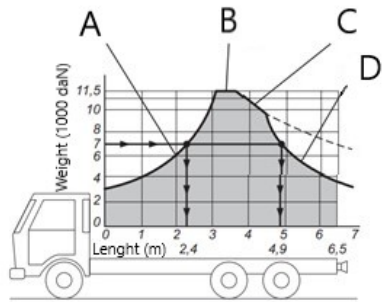

Load distribution

- A- Permissible front axle weight
- B- Permissible maximum weight
- C- Permissible rear axle weight
- D- Driving characteristic change limit

6.3.1. Load Security

The international Highways Regulations specify the maximum loading capacities of tractors, trucks, trailers, semi-trailers along with how and how much of the tonnage and dimensions of these loads are to be secured.

For instance, here, the distribution of the load amount that can be carried by a 6x2 truck per its axle, to the vehicle's weight center according to its horizontal and vertical distance.

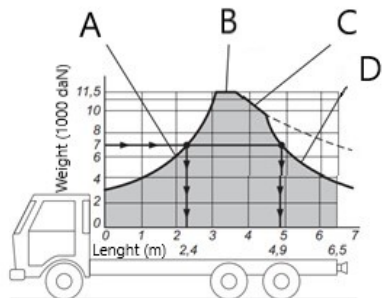

Load Distribution

- A- Permissible front axle weight
- B- Permissible maximum weight
- C- Permissible rear axle weight

D- Driving characteristic change limit

6.4. Load Distribution and Load Limits of Tractor Semi-trailer Combination

- Ensure that you made a proper load distribution in compliance with all laws, rules, and regulations.
- In the loading process, take the loading limits, total weight, and axle load capacities into the account.
- Ensure that you have performed the loading in compliance with the laws and regulations of all countries where you drive the vehicle.

The axle loads of the tractor/semi-trailer combination may vary in a broad range in relation to the various loading conditions. Comply with the permissible axle loads specified in the operation manual or the axle manufacturer's manual.

Whenever you are in doubt, have your loads checked at a proper weighing station.

***Axle load: This is the load conveyed by an axle or an axle group.**

6.5. Tilt Alert

Bu fonksiyon 3 derece ve üzeri eğimli zeminde indirme kaldırma sırasında kullanıcıyı sesli ikaz yoluyla uyarır.

7. INSPECTION AND MAINTENANCE

7.1. Safety Instructions

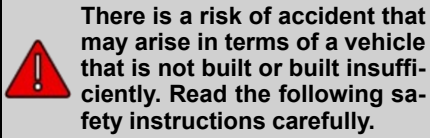

- Obey all traffic laws, rules and regulations.
- Comply with all environmental regulations. When removing operation, maintenance and cleaning residues, act according to these rules.
- Maintenance operations should be carried out by authorized services.

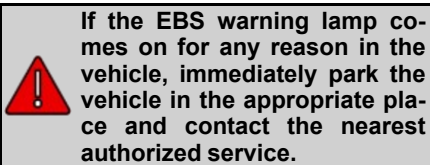

7.2. Main Principles

The purpose of the maintenance operations on the vehicle is to provide the following:

- Always maintain the operating status of the semi-trailer,
- To prevent unexpected breakdowns and to extend the life of the vehicle,
- To prevent permanent damage to the semi-trailer,
- To ensure that the semi-trailer maintains its value,
- Reducing repair time for unavoidable repairs,
- The vehicle should be regularly cleaned and kept clean.

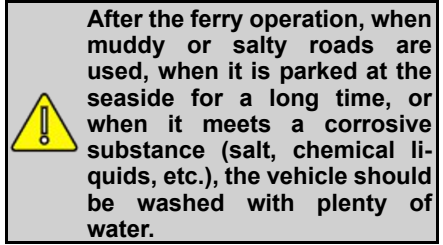

7.3. Checks to Be Performed Of The Time of the Delivery

- Check that the electrical system and connections and all lighting elements, brake and signal lamps are working properly.
- Check that the documents of the vehicle are in the vehicle.
- Grease the wheel plate and king pin.
- Check the tightness of the wheel nuts.
- Check that the landing gear works in both speed ranges.

7.4. Cataphoresis Coating

Your vehicle chassis or components may be cataphoresis coated.

Electro-coating (Cataphoresis) method is a coating method based on the accumulation of paint on the part with electric current. The most complicated parts and assemblies that require a high level of performance in terms of painting quality are covered.

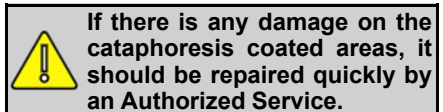

7.5. Periodic Maintenance and Controls

For periodic maintenance and checks, see the warranty and maintenance manual.

7.6. Important Warning!

- Check the lining thickness periodically. If the lining thickness has fallen below half, more frequent checks must be made and the lining must be changed by applying to the authorized service before the lining is finished. In the same way, the wear checks of the brake discs should be made periodically, and if there are excessive deformation and cracks on the disc surfaces, an authorized service should be immediately applied. In addition, the caliper piston and bellows should be visually checked and the operability should be checked by moving the caliper back and forth.
- For the necessary controls and periodic maintenance of the axles in your vehicle, the points in the service and maintenance instructions booklet given by the axle manufacturer with your vehicle should be applied meticulously and in accordance with the periods given in the same booklet. Failure to carry out such maintenance may affect the service life of the axles of the vehicle and may cause the axles to be out of warranty in case of a possible malfunction.
- The healthy operation of the brake system of the semi-trailer depends on the use of the semi-trailer with the same system and/or compatible tractor. For this reason, it is obligatory for the buyer to make the brake adjustment adjustment at the authorized service of the tractor company together with the tractor to which these semi-trailers / semi-trailers will be matched. In case the semi-trailer is paired and used with the tractor / tractors for which the adjustment of the semi-trailer is not made or cannot be made, the malfunctions and damages that may occur in the brake system or the tractor and the semi-trailer are outside the responsibility of our

company, and all responsibility in this regard belongs to the buyer.

7.7. Trouble Shooting

7.7.1. Safety Regulations

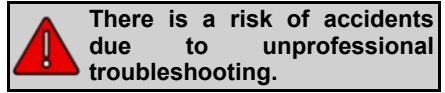

Read the following safety regulations.

- Comply with all laws, rules, and regulations to prevent accidents.
- Comply with all environmental protection rules. Dispose of process residues, cleaning aids and other residues in accordance with these rules.
- Troubleshooting work should only be carried out by trained personnel.
- Before troubleshooting, park the vehicle on a firm, and even surface and level it, and make sure that it is secured against sliding/tipping.
- Upon completion of the repair, ensure that all protective devices are correctly placed and secured.
- Only use original spare parts!



In cold weather, ice may form on the floor. Care should be taken while walking.



For the repair process of the malfunctioning product, follow the instructions given by the manufacturer of that product in the user manual.

7.7.2. Spare Tire Replacement



Wheel nuts that are not tightened properly will loosen. This may cause accidents. Tighten the wheel nuts to the specified torque. You can find the torque values in the manufacturer's manual for "Axles". Check the tightness of the nuts immediately after each tire change.

Removing the tire:

- Park the vehicle in a safe place away from traffic.
- Secure the vehicle with wheel chocks against rolling away or tipping over.
- Apply the springloaded parking brake. (See: "Construction Components and Use of Semi-trailer" for detailed information.)



Lock the tractor securely to prevent spontaneous or unintentional movement of the tractor during tire changing

- Loosen the wheel nuts only one turn.
- Place the lever jack under the axle as close as possible to the tire to be replaced.
- Raise the axle until the tire to be replaced is no longer in contact with the ground. Remove the wheel nuts.



Take the damaged wheel off the axle, grab the wheel only by the right and left cheeks, never remove it by holding the top or bottom.

Remove the spare tire from its holder. See spare tire holder section for detailed information.

Fitting The Spare Tire:

- Position the spare tire as close to the wheel hub as possible.
- Lightly oil the nut threads when refitting the wheel.
- Insert a bar directly under the tire and push the wheel bolts into the holes of the rim by leveraging. Be careful not to damage the threads of the studs during this process.
- Tighten the wheel nuts as much as possible by hand tightening.
- Tighten the nuts with the wrench in the order shown in the picture.
- Lower the jack and tighten the wheel nuts in the same sequence with the required torque. Repeat this process after the first 80 km and daily for the first week.
- Check the wheel nuts for torque every week.



Possible problems that may arise in the future can be prevented by checking all the bolt holes on the rims against ovalization at regular intervals.

Excessive tightening of the nuts of the wheel bolts will cause radial deformations around the hole, and if not tightened enough, it will cause deformations around the hole.

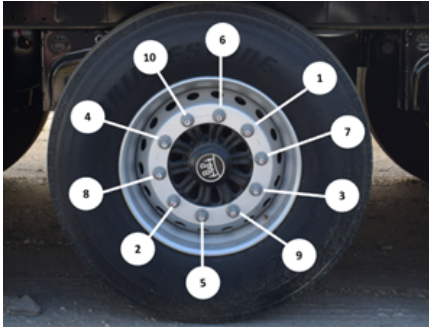

Bolt Holes In Rimes



Follow all maintenance instructions, including those of the manufacturer of the vehicle parts, and always keep these instructions in your vehicle.



The manufacturer cannot be held responsible for wear and defects caused by excessive force, or for malfunctions caused by unauthorized modifications. Irregularities or functional faults in the braking system must be rectified immediately! Only use vehicles whose brake system is functioning properly.

7.7.3. Activation of the Spring-Loaded Parking Brake Emergency Release Button



When manually releasing the parking brake, there is a risk of the vehicle tipping over. Make sure the vehicle is on firm, level, and even ground, and secure it against tipping.

7.7.4. Brake System



When manually releasing the parking brake, there is a risk of the vehicle tipping over. Make sure the vehicle is on firm, level, and even ground, and secure it against tipping.

Brake system work must only be carried out by specially trained personnel at authorized service centers.



Follow all maintenance instructions, including those of the manufacturer of the vehicle parts, and always keep these instructions in your vehicle.



The manufacturer cannot be held responsible for wear and defects caused by excessive force, or for malfunctions caused by unauthorized modifications. Irregularities or functional faults in the braking system must be rectified immediately! Only use vehicles whose brake system is functioning properly.



Kässbohrer Sales GmbH

Ulm | Im Katzenwinkel 5, 88480 Achstetten, Deutschland | T +49 (0) 7392 96797-0 | F +49 (0) 7392 96797-67

Goch | Siemensstraße 74, 47574 Deutschland | T +49 (0) 2823 9721-0 | F +49 (0) 2823 9721-21 | E info@kaessbohrer.com | www.kaessbohrer.com
info@kaessbohrer.com | spareparts@kaessbohrer.com | aftersales@kaessbohrer.com

Kässbohrer

Ingenuity, since 1893